



1149 E. South 11th Street • Abilene, Texas 79602

**Invitation For Bids (IFB)**

# **Unit Renovations 4 Units Riviera & Brailsford**

**Date Issued**

*May 6, 2026*

**IFB # *AHA-2026-004***

**Closes**

*June 5, 2026 @ 5:00 PM CDT*

**Meghan Monson, Special Projects Analyst**

**Prepared by**

Patterson & Associates Consulting, LLC  
for the Abilene Housing Authority

# TABLE OF CONTENTS

<b>TABLE OF CONTENTS</b>	<b>2</b>
<b>I. AHA Background, IFB Objective(s), Evaluation, and Information</b>	<b>3</b>
A.AHA’s Background, Mission, and Impact	3
B. IFB Objective(s)	3
C. IFB Information and Timeline:	4
D. Bid Evaluation Process:	5
E. Submission Requirements	6
<b>II. Scope of Work</b>	<b>10</b>
A. General Scope of Work	10
B. Contractor Responsibilities	10
<b>III. Exhibits &amp; Attachments</b>	<b>17</b>
A. HUD & Federal Form Exhibits	17
<b>IV. Forms &amp; Attachments</b>	<b>17</b>
A. Federal	18
B. AHA and State of Texas Forms	18

# I. AHA Background, IFB Objective(s), Evaluation, and Information

## A. AHA's Background, Mission, and Impact

- (1) **The Abilene Housing Authority (AHA)** is committed to providing quality affordable housing in a suitable living environment to low- and moderate-income individuals and families without discrimination; and to creating economic opportunities for our customers to become self-sufficient.
- (2) **Our Mission and Impact:** AHA is changing the face of affordable and attainable housing opportunities by providing low-income rental possibilities that enable our clients to flourish in the community. AHA accomplishes this by assisting our clients in elevating themselves to the next level of self-sufficiency and personal responsibility through life-changing programs. Through its real estate development program, AHA also delivers stable investment opportunities for our development partners. The Abilene Housing Authority owns 213 Public Housing units and administers 1803 Housing Choice Vouchers in 20 Counties across West Central Texas. AHA also owns a 48-unit Senior Tax Credit property in conjunction with a developing partner that administers 19 Project Based Vouchers (PBV's) and 3 market rate units within the 48 units.

## B. IFB Objective(s)

- (1) **Objective of this Solicitation:** The Abilene Housing Authority (AHA) is soliciting sealed bids from qualified contractors for the renovation of four (4) residential units located at AHA-owned properties in Abilene, Texas. The scope of work includes, but is not limited to, interior renovations necessary to restore units to rent-ready condition, including demolition, carpentry, plumbing, electrical, HVAC, flooring, painting, and installation of fixtures and appliances, in accordance with AHA specifications and construction drawings.
- (2) **Qualifications:** All work must be performed in accordance with the specifications, plans, and unit scopes outlined in this IFB, including Attachment H – Unit Scopes of Work and Specifications. The Contractor is expected to evaluate existing conditions and adapt construction methods as necessary to complete all unfinished and deficient work resulting from prior contractor abandonment. Work includes multiple trades and must be performed in a coordinated, professional manner to deliver fully functional, code-compliant, and move-in-ready units. The Contractor must demonstrate experience with residential renovation and rehabilitation projects of similar size and complexity and shall comply with all applicable federal, state, and local laws, codes, and regulations.
- (3) **Goal:** This contract supports AHA's mission to provide safe, sanitary, and decent housing environments for low-income individuals and families across Abilene and West Central Texas. The goal of this project is to restore four (4) residential units to full

occupancy-ready condition by completing previously abandoned renovation work and correction of any deficiencies. AHA intends to award a contract to a single responsive and responsible bidder; however, AHA reserves the right to make multiple awards or award in part if it is determined to be in the best interest of the Authority.

**C. IFB Information and Timeline:**

Table C-1: Solicitation Activity	Date or Target Date
<b>1. AHA Contact for this solicitation</b>	Meghan Monson, Special Projects Analyst <a href="mailto:meghan.monson@abileneha.org">meghan.monson@abileneha.org</a>
<b>2. Solicitation Issued</b>	May 6, 2026
<b>3. How to Obtain the IFB</b>	The IFB will be posted online at AHA’s website, as well as at Housing Agency Marketplace ( <a href="https://ha.internationaleprocurement.com/">https://ha.internationaleprocurement.com/</a> )
<b>4. Pre-Bid Conference (Pre-Bid Walkthrough)</b>	May 8, 2026, at 10:30 AM 6001 N 6th St., Abilene, TX 79603
<b>5. Question submittal deadline</b>	May 21, 2026 Please submit questions at <a href="https://ha.internationaleprocurement.com/">https://ha.internationaleprocurement.com/</a>
<b>6. Response Deadline: <u>5:00 PM CDT On:</u></b>	June 5, 2026
<b>7. Proposal Submission</b>	<ol style="list-style-type: none"> <li>1. <i>Updates and addenda, including responses to questions will be posted in the eProcurement Marketplace website;</i></li> <li><i>And</i></li> <li>2. <i>All proposals to be submitted online as a PDF document uploaded as part of the online form: <a href="#">CLICK HERE</a>.</i></li> </ol>
<b>8. <u>Post-Deadline Status Only Questions (Available after Response Deadline only)</u></b>	To submit questions regarding the <u>status</u> of the solicitation, <a href="#">CLICK HERE</a> .

(1) AHA reserves the right to modify this schedule at its discretion. Notification of changes in connection with this solicitation will be made available to all interested parties via online notifications and/or an emailed Addendum.

- (2) This Invitation For Bids (IFB) contains specific submission requirements, a scope of work, as well as terms, conditions, and other pertinent information necessary for submitting a proposal.

## D. Bid Evaluation Process:

- (1) **Public Opening:** Each submission will be internally reviewed to establish responsiveness. The reviewer will ensure that all required materials are included and that no obvious deficiencies are evident. AHA reserves the right, in its sole discretion, to waive any informalities or minor irregularities and/or permit the cure of such deficiencies if it serves its best interests to do so. Any submission that fails to include all materials requested under this solicitation may be deemed non-responsive and, if determined to be non-responsive by AHA, will not be rated or ranked.
  - a. AHA reserves the right to accept or reject in part or reject all proposals and to resolicit new proposals. AHA may also reject any proposals that are incomplete or non-responsive, or that are submitted after the deadline.
- (2) **Responsive Evaluation:** After the public opening, the bid submittals received will be evaluated in private for responsiveness (i.e., meets the minimum requirements). Firms not meeting the minimums that are deemed to be non-responsive will be notified of such in writing by the AHA in a timely manner (in any case, in no less than 5 days after such determination is made).
- (3) **Responsible Evaluation:** The AHA will evaluate each bid submitted as to responsibility (i.e., a firm that is qualified, responsible, and able to provide the required services to the AHA). If the AHA claims that such a firm has the required ability, capability, experience, knowledge, licensing, insurance, and resources to provide the required services, the AHA may proceed with an award as detailed herein. If the AHA determines that such a firm is deemed to be not responsible, such a firm will be notified of such in writing by the AHA in a timely manner (in any case, in no less than 5 days after such determination is made); in such case, the AHA may proceed with the noted Responsive and Responsible Evaluations with the next lowest bidder.
  - a. Depending on the amount of the award, it is possible that the AHA may take such contract award to the AHA Board of Commissioners (BOC) for approval of the award prior to executing a contract with the apparent successful bidder.
  - b. AHA reserves the right to accept or reject in part or reject all proposals and to resolicit new proposals. AHA may also reject any proposals that are incomplete or non-responsive, or that are submitted after the deadline.

## E. Submission Requirements

**(1) Proposal Submission** (*Upload a PDF version via AHA's [Online Submission Form](#)*)

- a. The response to this IFB shall be submitted in the manner described in this Section. Failure to submit the Proposal in the manner specified may be cause for elimination of that Respondent from consideration for the award.
- b. Any submission received after the specified date and time will not be considered. Submissions must be made electronically through the online submission form using the link provided above. It is the responsibility of the bidder to ensure successful submission prior to the deadline.

Tab #	Description
1	<b>Form of Bid (Attachment A).</b> This Online Form is at the link to this IFB document. This form must be fully completed, executed where provided thereon and submitted online as a part of the proposal submittal. Use link above to access.
2	<b>HUD 5369-A.</b>
3	<b>Bid Bond.</b> If required, as detailed below under (3) Bid Bond.
4	<b>Bid Tabulation Sheet (Attachment C).</b>
5	<b>Licensing.</b> Submit under this tab, If applicable, a copy of the bidder's business license allowing that entity to provide such services within the City of Abilene, the County of Taylor, and/or the State of Texas. See the Attachment AHA Minimum Insurance Requirements.
6	<b>Proposed Services.</b> As more fully detailed with Section II Scope of Services, and the specifications document Attachments H and H1. The bidder shall clearly detail within the information submitted under this tab documentation showing: <ul style="list-style-type: none"> <li>• A brief description of the proposed safety and quality assurance program</li> <li>• Fully completed HUD-2530, Previous Participation Certification</li> <li>• Fully completed HUD-51000, Schedule of Amounts for Contract Payments</li> </ul>
7	<b>Profile of Firm Form (Attachment D).</b> The Profile of Firm Form is attached hereto as Attachment D to this IFB document. This 2-page Form must be fully completed, executed and submitted under this tab as a part of the proposal submittal.

Tab #	Description
8	<b>Managerial Capacity/Financial Viability.</b> The bidder/vendor company must submit a concise description of its managerial and financial capacity to deliver the proposed services, including brief professional resumes for the persons identified within areas (5) and (6) of Attachment D, Profile of Firm Form. Include the bidder's qualifications to provide the services, including a description of the background and current organization of the firm.
9	<b>Client Information &amp; References.</b> The proposer shall submit a listing of former or current clients, including Public Housing Authorities, for whom the proposer has performed similar or like services to those being proposed herein. The listing shall, at a minimum, include: Include a brief description of Respondent's business relationship with the reference. Client Name, Contact Name, Telephone Number, and a brief narrative description relating the scope of work performed.
10	<b>Subcontractor/Joint Venture Information (Optional Item).</b> The bidder shall identify hereunder whether or not he/she intends to use any subcontractors for this job, if awarded, and/or if the bid is a joint venture with another firm. Such information pertaining to subcontractors shall include for each such firm the: firm name; name of contact person; telephone and email address; and the State of Texas contractor license number.
11	<b>Payment &amp; Performance Bonds.</b> As detailed below under (4) Performance Bond; (5) Payment Bond.
12	<b>Insurance Certificates.</b> The apparent successful bidder will also direct its insurance broker or carrier to deliver directly to the Agency (by email is preferred). See the Attachment AHA Minimum Insurance Requirements.
13	<b>Abilene Housing Authority/State of Texas Forms.</b> As detailed below under (4) Performance Bond; (5) Payment Bond.
<b>Exhibits</b>	Respondent may include general information in this section the proposer believes it will assist AHA in evaluating their capabilities. (10-page limit)

**(2) Entry of Proposed Fees.** Unless otherwise stated herein, the proposed fees are all-inclusive of all related costs that the successful bidder will incur to provide, including, but not limited to: employee wages and benefits; clerical support; overhead; profit; licensing; insurance; materials; supplies; tools; equipment; long-distance telephone calls; travel; and document copying not specifically agreed to by the AHA, etc.

- a. Firm-fixed Fee to complete all the renovation work detailed and within Attachments H and H1 at the 4 units of Riviera and Brailsford.

- (3) **Bid Bond.** The bid bond or guarantee shall be included in the bid package submitted by each bidder for any proposed fee that is greater than \$100,000 (please see Submission Requirements, Tab 4). This bond ensures that if awarded the contract, the bidder will accept and perform the work under the contract. It also ensures that the bidder will not attempt to withdraw or otherwise not fulfill the contract. Finally, the bid bond ensures that the bidder will execute the contractual documents that are required within the time specified in the solicitation or forfeit all or part of the guarantee. A certified check, bank draft, U.S. Government Bonds at par value, bid bond secured by an acceptable surety company, or other negotiable instrument may be accepted as a bid guarantee. If the successful bidder refuses to sign the contract after award, the bid bond is forfeited, and the award will then go to the next lowest responsive and responsible bidder. If a bid bond or guarantee is not submitted with the bid, the AHA will reject the bid as non-responsive. The AHA anticipates that it will not return any bid bonds until the contract has been awarded and the required performance and payment(s) bonds have been furnished, until all bids have been rejected, or the time specified for acceptance of bids has expired. In fairness to the other bidders, the AHA may also choose to return the bid bonds if the AHA has a firm and reasonable assurance that the responsive and responsible bidder who submitted the lowest cost will execute the contract.
- (4) **Performance Bond.** The performance bond is meant to ensure that the contract is successfully completed. The performance bond guarantees that if the Contractor is unable to complete the contract, the surety company will step in to finish the work. In the case of a letter of credit or cash escrow, the AHA may use these funds to complete the contract work.
- (5) **Payment Bond.** The payment bond is a method of ensuring that the Contractor pays the subcontractors and suppliers. By requiring payment bonds, the AHA avoids becoming entangled in disputes concerning payment of subcontractors and suppliers by the general contractor. The surety underwriting the payment bond ensures that the contractors and suppliers will be paid. Often, performance and payment bonds are combined into a single document. Failure to pay subcontractors for work performed in commercial contracts may often lead to the subcontractor filing a mechanic's lien against the property owners to obtain payment for services rendered. The AHA contract requires the payment bond to prevent this problem and ensure that no lien will be filed against any AHA building or lot of ground. As a reminder, Clause 24 of form HUD-5370, General Conditions of the Contract for Construction (Attachment G-1 attached hereto) clearly forbids the placement of any liens and is binding on any contractor, subcontractor, and material supplier.
- (6) **Bonding Companies.** An acceptable surety (bonding) company is one that is authorized to do business in the State of Ohio and is acceptable to HUD and the Agency. The surety must be listed on the most recently published U.S. Treasury Circular 570 (often referred to as the T-List). Individual sureties are not permitted. Circular 570 is available from the U.S. Department of the Treasury, Financial Management Service, Surety Bond Branch, Room #262C, 401 14th Street, S.W., Washington, D.C. 20227. The T-List may also be accessed on the Internet at: <http://www.fms.treas.gov/c570/index.html> .
- (7) **Bonding Requirements.** In order to encourage participation by a broad range of competitors, including small and minority firms, HUD has provided for alternate bid and

contract guarantees. These apply to all construction projects greater than \$100,000 (though, at the AHA's discretion, may apply to smaller projects), whether development or modernization, funded pursuant to the U.S. Housing Act of 1937, as amended. As a result, the contractors for all construction projects shall be required to submit the following bid and contract guarantees. Please note that only the bid bond is required at the time of bid; however, one of the purposes of the bid bond is to provide the AHA with assurance that the successful bidder will indeed obtain the necessary performance and payment bonds. The required bonds include a bid guarantee from each bidder, equivalent to 5% of the bid price and, from the successful bidder, one of the following:

- a. A performance and payment bond for 100% of the contract price; or,
- b. Separate payment and performance bonds each for 50% of more of the contract price; or,
- c. A 20% cash escrow; or,
- d. A 25% irrevocable letter of credit.

**(8) Inadequate Surety.** If the low bidder fails to provide an acceptable assurance of completion (payment and performance bonds) after the award of the contract, the AHA may consider the bid guarantee forfeited and notify the surety company. The contract is then terminated for default. The amount to be recovered from the bid bond or guarantee will typically equal at least the difference between the defaulted bid and the next higher acceptable bid or the amount by which the bid accepted by re-soliciting exceeds the defaulted contract.

**(9) Prior AHA Approval Required.** Please note that the successful bidder shall NOT conduct any additional work without the prior written authorization of the AHA representative (via delivery of a Task Order, which may take the form of an e-mail). Failure to abide by this directive shall release the AHA of any obligation to pay the successful bidder for any work conducted without the noted prior written authorization.

## II. Scope of Work

Contractor shall provide all labor, materials, tools, supervision, permits, and incidentals required to renovate four (4) units to a rent-ready condition. Work includes, but is not limited to:

- a. Demolition and removal of incomplete or defective work
  - b. Installation of cabinetry, doors, and hardware
  - c. Plumbing fixture replacement
  - d. Electrical upgrades and lighting replacement
  - e. Appliance installation
  - f. HVAC and ventilation work
  - g. Interior finishes, including flooring, wall repair, and painting
  - h. Final cleaning and preparation for occupancy
- (1) The Contractor acknowledges that this project involves completion of previously abandoned work. The Contractor shall include all necessary costs to complete the project based on a reasonable inspection of existing conditions. Claims for additional compensation due to visible or reasonably discoverable conditions will not be accepted.
  - (2) The Contractor shall assume responsibility for the correction of defective or incomplete work identified during construction, regardless of whether such work was performed by a previous contractor.
  - (3) The Contractor shall not rely solely on the drawings or scopes provided and shall verify all quantities, conditions, and requirements prior to submitting a bid.

### A. General Scope of Work

- (1) The work shall consist of, as detailed herein and within Attachment H, to perform the required unit renovation work at the following units:
  - a. 2250 Vogel St. Unit B25, Abilene, TX
  - b. 2250 Vogel St. Unit D6, Abilene, TX
  - c. 3001 N. 6th St. Unit 102, Abilene, TX
  - d. 3001 N. 6th St Unit 208, Abilene, TX

### B. Contractor Responsibilities

- (1) **Access for Emergency Vehicles.** a) The Contractor shall ensure that any equipment and/or vehicles that he/she places on the work site shall not be placed in such a position to interfere with access by any emergency vehicles or traffic by the public at large. The AHA reserves the right to approve or reject (and demand the movement) of the placement of such equipment or vehicles at any time during the performance of the contracted work if, in the

opinion of the AHA, the placement of such equipment or vehicles does interfere with such traffic.

- (2) As-built Record Documents.** Do not use Record Documents for construction purposes; the documents shall be protected from loss in a secure location; provide access to Record Documents for the AHA's reference.

  - a. If issued, maintain a clean, undamaged set of blue or black line white-prints of Contract Drawings and Shop Drawings. Markup these drawings to show the actual installation. Mark whichever drawing is most capable of showing conditions accurately. Give particular attention to concealed elements that would be difficult to measure and record at a later date.
- (3) Build America, Buy America (BABA) Act Requirements.** If applicable (meaning for construction projects greater than \$250,000), by receipt of a contract award, it shall be the responsibility of the successful bidder to agree, certify, and eventually show proof that products provided and installed by the contractor are in full compliance with the requirements of the noted Act. More information is available at the following link: <https://www.hud.gov/baba>.
- (4) Communication.** The AHA shall be the primary on-site point of contact for the Contractor pertaining to this work. The Contractor shall be free to converse and communicate with the AHA during or between visits; however, all requests for changes or decisions shall be submitted to the AHA and approved by the Executive Director after receipt and consideration of a written request from the AHA. The AHA anticipates that it will typically make a decision in such matters within 3 workdays of receipt, though such response time frame may be shorter or longer depending on the situation; accordingly, the Contractor shall be required to submit such written requests in as timely a manner as reasonably possible. When construction commences, all communication must be directed to the designated AHA contact person only.
- (5) Contract End Terms.** Upon completion of the project, the Contractor must submit the following:

  - a. A separate payment request for retainage
  - b. A one-year warranty letter from the Contractor
  - c. Consent to Surety to Final Payment
  - d. Contractor's Affidavit of Release of Liens
  - e. Contractor's Certificate and Release
  - f. As-built's (Mark-ups delivered to AHA)
- (6) Contractor's Request for Payment.** As detailed within Chapter 9, Procurement and Contract Administration, of Handbook 7485.1.

  - a. The AHA is responsible for making progress payments. Typically, progress payments for acceptable work and materials delivered and stored on the site will be made at 30-day intervals.
  - b. Payment will be based on the percentage of work completed during a one-month period.

- c. A 10% retention will be withheld on each payment request. A separate payment request for the return of the retention will be required at the completion of the work.
- d. **Request for Payment Forms.** The Contractor shall submit a request for payment for this project on the following forms, each as may be appropriate:

Attachment No.	Form Description
III.A.8	Form HUD-51000 (1/2014), Schedule of Amounts for Contract Payments; NOTE: The AHA also retains the right to require any bidder (but most likely the apparent low bidder) to submit this fully completed form to the AHA at any point after the bid submittal deadline—this typically will occur when the AHA wishes to do an analysis of the bidder’s proposed cost to ascertain as to whether or not the bidder’s proposed cost is realistic, fair, and/or reasonable.
III.A.9	Form HUD-51001 (1/2014), Periodic Estimate for Partial Payment
III.A.10	Form HUD-51002 (1/2014), Schedule of Change Orders
III.A.11	Form HUD 51003 (1/2014), Schedule of Materials Stored
III.A.12	Form HUD-51004 (1/2014), Summary of Materials Stored
III.A.13	Form HUD-5372 (1/2014), Construction Progress Schedule
III.A.14	All relevant Subcontractors Weekly Certified Payrolls must accompany the payment request, utilizing form WH-347
N/A	<b>Retainage.</b> The Request for Payment form must list and clearly identify the retainage in the amount of 10% as a deduction to the subtotal of charges on the Request for Payment.

- e. **Review and Approval.** The AHA will review each such Contractor request for payment and will approve the payment only if the following conditions are met. If the Contractor requests payment items which have not been completed in a satisfactory manner (“satisfactory,” as determined at the sole discretion of the AHA), the AHA shall hold payment for the unsatisfactory items, and pay the balance of the request (i.e., the undisputed portion). The AHA shall ensure:
  - a. The request for payment is consistent with the AHA-approved schedule of amounts for contract payments; and,
  - b. As further detailed within the preceding Section III.B.5.c herein, the total of the request for payment does not include the amount to be retained by the AHA under the contract (retention or retainage); and,
  - c. The work covered by the request for payment has been performed in accordance with the construction documents; and,

- d. The Periodic Estimate for Partial Payment has been properly executed on all applicable supporting documentation submitted; and,
  - e. The Contractor has submitted all required reports, such as payroll reports.
- e. **Distribution of Documents.** The Contractor shall submit 2 original copies and 1 additional copy of all documentation required. The AHA shall retain the 2 original Periodic Estimate for Partial Payment requests and all applicable supporting documentation for its file and return 1 copy of all such forms to the Contractor.
- (7) Debris.** The Contractor shall clean work areas daily, at the end of the workday, of all work-generated debris which may endanger the safety of others (the public, AHA residents, etc.).
- a. All work areas must be kept sanitary and clean of any trash. Debris from work must be removed from living areas.
  - b. The Contractor must examine the work area and determine any unsuitable work conditions.
  - c. Any required removal or replacement of this work caused by unsuitable conditions will be just cause for the Contractor to bear the expense. Notice of unsuitable conditions shall be brought to the AHA's representative in written form.
  - d. The Contractor shall provide a construction dumpster as needed to dispose of and remove all debris. The use of the AHA dumpsters is prohibited.
- (8) Delivery of Materials.** The Contractor and each Subcontractor shall inspect the site and determine the availability of storage space and trucking facilities for bringing materials or equipment into the building, as well as any other factors affecting the work under this Contract.
- a. Long-lead items should be ordered as soon as possible after contracts are signed to expedite shop drawings and the delivery of materials to the site. Advance planning will be important to ensure the timely delivery of materials.
- (9) Final Inspection and Punch List.** AHA shall provide one (1) final inspection site visit to develop the final Punch List when the following are completed:
- a. All new construction and installations are 100% complete and operational.
  - b. A test-and-balance report has been completed and delivered to the AHA for review.
  - c. All final inspections and permits have been closed and delivered to the Contractor and AHA.
  - d. When the Contractor has completed all the required work and feels substantial completion has been achieved, the Contractor must document and request a final inspection and punch list be performed by the AHA. This will document the one (1) final inspection and punch list by AHA.
  - e. When the Contractor has completed all the punch list items, the Contractor shall document and request a final re-inspection by the AHA.
  - f. The AHA will provide one (1) final site visit for re-inspection of the punch list items.
  - g. If the AHA feels the punch list items have not been completed satisfactorily, notice will be given to the Contractor.
  - h. All punch list items must be completed at the time of substantial and final acceptance.

- i. If the final punch list items are not complete at the time of the final inspection, the retention will be withheld until final acceptance by AHA.
- (2) Layout and Dimensions.** The Contractor and each Subcontractor shall verify and field-check all plan dimensions, elevations, and quantities for the existing building units within their respective responsibilities before proceeding with work. Discrepancies must be brought to the AHA's attention in writing for clarification or correction. Any Contractor failing to exercise such precautions shall be held responsible for the cost of correcting any resulting errors.
- (10) Maintenance Manuals (if applicable).** Organize maintenance data into sets of manageable size. Bind in individual heavy-duty 2-inch, 3-ring vinyl-covered binders, with pocket folders for folded sheet information. Mark identification on the front and spine of each binder. Include the following information:
- a. Maintenance Emergency Instructions
  - b. Spare parts list
  - c. Copies of warranties
  - d. Wiring diagrams
  - e. Recommended "turn around" cycles
  - f. Inspection procedures
  - g. Shop Drawings and Product Data
- (11) Operating and Maintenance Instructions.** Arrange for the installer of equipment requiring regular maintenance to meet with the Owner's personnel to provide instruction on proper operation and maintenance. Include a detailed review of the following:
- a. Maintenance manuals
  - b. Spare parts and materials
  - c. Tools
  - d. Lubricants
  - e. Control sequences
  - f. Hazards
  - g. Warranties and bonds
  - h. Maintenance agreements and similar continuing commitments
  - i. Start up and shutdown
  - j. Emergency operations
  - k. Noise and vibration adjustments
  - l. Safety procedures
- (12) "Or Equal" Specifications.** Herein, or within the attached specifications, whenever the AHA has listed a specific brand name, the words "or equal" shall automatically apply thereto. This term "or equal" means that the apparent successful bidder may propose to provide an alternate product as long as such proposed alternate product, in the opinion of the AHA, meets the minimum specifications. As detailed within Section 9.3.B.3 of HUD Procurement Handbook 7460.8 REV 2, brand names are listed herein for "establishing design and quality standards" for the product identified. If a bidder wishes to provide a different product than the product the AHA has identified, the AHA will be pleased to respond to any

specific written request from a bidder with a listing of the “essential characteristics” for any such product (the bidder may also, if he/she wishes, wait to see if the firm is the apparent successful bidder then submit such written request after the bid submittal deadline when the AHA will evaluate such alternate products, if submitted).

- (13) **Payroll Reports.** The Contractor shall, during the term of the work, within 7 days of the end of any weekly payroll period, forward to the AHA a copy of the weekly payroll.
- a. The Contractor is hereby made aware that the AHA will conduct periodic on-site wage surveys of the Contractor's staff working at the site. It is the responsibility of the Contractor to ensure that such work staff cooperate fully with the AHA interviewer. Relating to such interviews, please also see form HUD-11 (08/2004), Attachment G-13, attached hereto.
- (14) **Permits.** The Contractor shall obtain any and all required permits pertaining to any assigned work at his/her expense.
- (15) **Required Licensing.** The Contractor(s) shall be in possession of any current and appropriate licensing, registrations, and permits that may be required by the City of Abilene, Taylor County, and/or the State of Texas for the performance of the Work. The Contractor shall be duly registered and authorized to conduct business in the State of Texas and shall comply with all applicable provisions of the Texas Occupations Code, including but not limited to Chapter 1305 (Electrical Work Licensing), Chapter 1301 (Plumbing Licensing), and any other applicable state and local regulations governing general construction, HVAC, and related trades, as well as applicable provisions of the Texas Local Government Code. The Contractor will be required to provide the AHA with proof of such current licensing, registrations, and authorizations prior to contract execution.
- (3) **Retainage.** Retainage for this work shall be in the amount of 10 percent, applied to each payment until final payment, at which time all retainage held will be paid by the AHA to the Contractor.
- (4) **Safety.** It shall be the responsibility of the Contractor to ensure, at all times during the performance of the work, to the maximum extent feasible, to protect the safety of AHA residents and staff, the Contractor's staff, subcontractors, and the public. This shall include, but not be limited to, compliance with all OSHA-related Federal and local laws, codes, and regulations.
- (5) **Security during Work.** The Contractor shall take all means necessary to maintain the security of the area in which they are working. These security measures must be carried out on a twenty-four-hour basis, not just during normal work hours.
- (16) **Site Assessment.** The Contractor and contracted subcontractors are strongly encouraged to examine the project site before submitting a bid.
- a. A Pre-bid Conference and walk-through is scheduled as noted within C. IFB Information and Timeline. Due to the project's complexity, attendance is strongly encouraged but not mandatory.

- b. Additional site visits after the Pre-bid Conference may be scheduled. The Contractor must contact the AHA Contact Person listed within C. IFB Information and Timeline to schedule a site visit. Allow a minimum of three (3) business days to schedule an appointment. Unscheduled visits are prohibited.
- (17) **Temporary Facilities.** It shall be the responsibility of the Contractor to provide any temporary facilities that may be required, including, but not limited to, temporary toilets, water, fencing, barricades, lighting, planking, signage, and guardrails, etc. Accordingly, it shall be the responsibility of the Contractor to secure and maintain such items during the term of the work.
- (18) **Time Completion.** The Contractor shall commence work under the ensuing contract on a date to be specified in the Notice to Proceed (NTP) form issued by the AHA and shall fully complete all work thereunder within 180 calendar days of execution of the NTP. NOTE: Any bidder with concerns regarding the noted time of completion may raise them at the Pre-bid conference. Normal working hours shall be Monday through Friday, 8:00 AM to 5:00 PM. All other working hours require pre-approval. Provide a minimum of five (5) working days for approval and planning.
- (19) **Tools/Equipment/Materials.** The Contractor shall ensure that at all times during the work, tools, equipment, and materials are handled, placed, and stored in a secure and safe manner so as to protect all parties, including, but not limited to, the Contractor's workers, AHA tenants and staff, and the public at large. The Contractor shall ensure that during non-working hours, such items are not left unattended on the job site when such safety may be compromised. If applicable, as the building the Contractor will be working in is occupied by housing tenants, including a number of elderly/disabled or special needs persons, it will be especially important that traffic areas are clear for access and egress.
- (20) **Weekends.** Unless otherwise approved by the AHA in writing, the Contractor shall not perform work on AHA property during a holiday or weekend days (Saturday or Sunday).
- (21) **Work Standards.** It is the Contractor's responsibility to ensure that each worker provided by the Contractor is fully trained and qualified to perform any assigned work. Accordingly, all work provided shall be guaranteed by the Contractor to be performed in a workmanlike manner and in accordance with all applicable laws, codes, and/or regulations, including those issued by, but not limited to, the Taylor County (and/or, if applicable, any city jurisdiction therein in which work will be performed), and/or the State of Ohio, or any applicable Federal AHA. Smoking is prohibited within the building and on the building's property boundaries.

### **III. Exhibits & Attachments**

These forms and attachments do not need to be returned as part of the response package.

#### **A. HUD & Federal Form Exhibits**

1. HUD Form 5369, Instructions to Bidders for Contracts
2. HUD-5370, General Conditions for Construction Contracts
3. HUD Form 5370-C, General Conditions for Non-Construction Contracts (W/O Maintenance)
4. HUD Form 5370-C, General Conditions for Non-Construction Contracts (with Maintenance)
5. HUD-92554M, Supplementary Conditions to the Construction Contract
6. HUD-2554, Supplementary Conditions of the Contract for Construction
7. HUD-4010, Federal Labor Standards Provisions
8. Form HUD-51000 (1/2014), Schedule of Amounts for Contract Payments
9. Form HUD-51001 (1/2014), Periodic Estimate for Partial Payment
10. Form HUD-51002 (1/2014), Schedule of Change Orders
11. Form HUD 51003 (1/2014), Schedule of Materials Stored
12. Form HUD-51004 (1/2014), Summary of Materials Stored
13. Form HUD-5372 (1/2014), Construction Progress Schedule
14. Form WH-347, Davis-Bacon and Related Acts Weekly Certified Payroll
15. HUD-11, Record of Employee Interview
16. 2025 Davis-Bacon Wage Rate
17. Standard Form 24, Bid Bond
18. Standard Form 25A, Payment Bond
19. Standard Form 25, Performance Bond

#### **B. Scope of Work and Unit Information**

1. Unit Scopes of Work Specifications (Attachment H)
2. Riviera and Brailsford Unit Renovation Construction Drawings (Attachment H1)

## IV. Forms & Attachments

These forms and attachments must be returned with the proposal response.

### A. Federal

1. HUD Form 5369-A Representations, Certifications, and Statements of Bidders
3. Certificate of Insurance (AHA Minimum Insurance Requirements are attached)
4. Form SF-LLL, Disclosure of Lobbying Activities
5. HUD Form 50071 Certificate of Payments to Influence Federal Transactions

### B. AHA and State of Texas Forms

1. Form of Bid (Attachment A, eForm)
6. Bid Tabulation Sheet
7. Certificate of Interested Parties Form 1295 <https://www.ethics.state.tx.us/filinginfo/1295>
8. Conflict of Interests Questionnaire Form CIQ
9. Profile of Firm Form
10. Company Biography
11. Listing of Proposed Subcontractors
12. Section 3 Statement
13. Respondent s Certification
14. Acknowledgment of Addendum s
15. Business References
16. Form of Non-Collusive Affidavit

## **III. Exhibits & Attachments**

### **A. HUD & Federal Form Exhibits**

**U.S. Department of Housing and  
Urban Development**  
Office of Public and Indian Housing

**Instructions to Bidders for Contracts  
Public and Indian Housing Programs**

---

# Instructions to Bidders for Contracts

## Public and Indian Housing Programs

### Table of Contents

Clause	Page
1. Bid Preparation and Submission	1
2. Explanations and Interpretations to Prospective Bidders	1
3. Amendments to Invitations for Bids	1
4. Responsibility of Prospective Contractor	1
5. Late Submissions, Modifications, and Withdrawal of Bids	1
6. Bid Opening	2
7. Service of Protest	2
8. Contract Award	2
9. Bid Guarantee	3
10. Assurance of Completion	3
11. Preconstruction Conference	3
12. Indian Preference Requirements	3

### 1. Bid Preparation and Submission

(a) Bidders are expected to examine the specifications, drawings, all instructions, and, if applicable, the construction site (see also the contract clause entitled **Site Investigation and Conditions Affecting the Work** of the *General Conditions of the Contract for Construction*). Failure to do so will be at the bidders' risk.

(b) All bids must be submitted on the forms provided by the Public Housing Agency/Indian Housing Authority (PHA/IHA). Bidders shall furnish all the information required by the solicitation. Bids must be signed and the bidder's name typed or printed on the bid sheet and each continuation sheet which requires the entry of information by the bidder. Erasures or other changes must be initialed by the person signing the bid. Bids signed by an agent shall be accompanied by evidence of that agent's authority. (Bidders should retain a copy of their bid for their records.)

(c) Bidders must submit as part of their bid a completed form HUD-5369-A, "Representations, Certifications, and Other Statements of Bidders."

(d) All bid documents shall be sealed in an envelope which shall be clearly marked with the words "Bid Documents," the Invitation for Bids (IFB) number, any project or other identifying number, the bidder's name, and the date and time for receipt of bids.

(e) If this solicitation requires bidding on all items, failure to do so will disqualify the bid. If bidding on all items is not required, bidders should insert the words "No Bid" in the space provided for any item on which no price is submitted.

(f) Unless expressly authorized elsewhere in this solicitation, alternate bids will not be considered.

(g) Unless expressly authorized elsewhere in this solicitation, bids submitted by telegraph or facsimile (fax) machines will not be considered.

(h) If the proposed contract is for a Mutual Help project (as described in 24 CFR Part 905, Subpart E) that involves Mutual Help contributions of work, material, or equipment, supplemental information regarding the bid advertisement is provided as an attachment to this solicitation.

### 2. Explanations and Interpretations to Prospective Bidders

(a) Any prospective bidder desiring an explanation or interpretation of the solicitation, specifications, drawings, etc., must request it at least 7 days before the scheduled time for bid opening. Requests may be oral or written. Oral requests must be confirmed in writing. The only oral clarifications that will be provided will be those clearly related to solicitation procedures, i.e., not substantive technical information. No other oral explanation or interpretation will be provided. Any information given a prospective bidder concerning this solicitation will be furnished promptly to all other prospective bidders as a written amendment to the solicitation, if that information is necessary in submitting bids, or if the lack of it would be prejudicial to other prospective bidders.

(b) Any information obtained by, or provided to, a bidder other than by formal amendment to the solicitation shall not constitute a change to the solicitation.

### 3. Amendments to Invitations for Bids

(a) If this solicitation is amended, then all terms and conditions which are not modified remain unchanged.

(b) Bidders shall acknowledge receipt of any amendment to this solicitation (1) by signing and returning the amendment, (2) by identifying the amendment number and date on the bid form, or (3) by letter, telegram, or facsimile, if those methods are authorized in the solicitation. The PHA/IHA must receive acknowledgement by the time and at the place specified for receipt of bids. Bids which fail to acknowledge the bidder's receipt of any amendment will result in the rejection of the bid if the amendment(s) contained information which substantively changed the PHA's/IHA's requirements.

(c) Amendments will be on file in the offices of the PHA/IHA and the Architect at least 7 days before bid opening.

### 4. Responsibility of Prospective Contractor

(a) The PHA/IHA will award contracts only to responsible prospective contractors who have the ability to perform successfully under the terms and conditions of the proposed contract. In determining the responsibility of a bidder, the PHA/IHA will consider such matters as the bidder's:

- (1) Integrity;
- (2) Compliance with public policy;
- (3) Record of past performance; and
- (4) Financial and technical resources (including construction and technical equipment).

(b) Before a bid is considered for award, the bidder may be requested by the PHA/IHA to submit a statement or other documentation regarding any of the items in paragraph (a) above. Failure by the bidder to provide such additional information shall render the bidder nonresponsible and ineligible for award.

---

## 5. Late Submissions, Modifications, and Withdrawal of Bids

(a) Any bid received at the place designated in the solicitation after the exact time specified for receipt will not be considered unless it is received before award is made and it:

(1) Was sent by registered or certified mail not later than the fifth calendar day before the date specified for receipt of offers (e.g., an offer submitted in response to a solicitation requiring receipt of offers by the 20th of the month must have been mailed by the 15th);

(2) Was sent by mail, or if authorized by the solicitation, was sent by telegram or via facsimile, and it is determined by the PHA/IHA that the late receipt was due solely to mishandling by the PHA/IHA after receipt at the PHA/IHA; or

(3) Was sent by U.S. Postal Service Express Mail Next Day Service - Post Office to Addressee, not later than 5:00 p.m. at the place of mailing two working days prior to the date specified for receipt of proposals. The term "working days" excludes weekends and observed holidays.

(b) Any modification or withdrawal of a bid is subject to the same conditions as in paragraph (a) of this provision.

(c) The only acceptable evidence to establish the date of mailing of a late bid, modification, or withdrawal sent either by registered or certified mail is the U.S. or Canadian Postal Service postmark both on the envelope or wrapper and on the original receipt from the U.S. or Canadian Postal Service. Both postmarks must show a legible date or the bid, modification, or withdrawal shall be processed as if mailed late. "Postmark" means a printed, stamped, or otherwise placed impression (exclusive of a postage meter machine impression) that is readily identifiable without further action as having been supplied and affixed by employees of the U.S. or Canadian Postal Service on the date of mailing. Therefore, bidders should request the postal clerk to place a hand cancellation bull's-eye postmark on both the receipt and the envelope or wrapper.

(d) The only acceptable evidence to establish the time of receipt at the PHA/IHA is the time/date stamp of PHA/IHA on the proposal wrapper or other documentary evidence of receipt maintained by the PHA/IHA.

(e) The only acceptable evidence to establish the date of mailing of a late bid, modification, or withdrawal sent by Express Mail Next Day Service-Post Office to Addressee is the date entered by the post office receiving clerk on the "Express Mail Next Day Service-Post Office to Addressee" label and the postmark on both the envelope or wrapper and on the original receipt from the U.S. Postal Service. "Postmark" has the same meaning as defined in paragraph (c) of this provision, excluding postmarks of the Canadian Postal Service. Therefore, bidders should request the postal clerk to place a legible hand cancellation bull's eye postmark on both the receipt and Failure by a bidder to acknowledge receipt of the envelope or wrapper.

(f) Notwithstanding paragraph (a) of this provision, a late modification of an otherwise successful bid that makes its terms more favorable to the PHA/IHA will be considered at any time it is received and may be accepted.

(g) Bids may be withdrawn by written notice, or if authorized by this solicitation, by telegram (including mailgram) or facsimile machine transmission received at any time before the exact time set for opening of bids; provided that written confirmation of telegraphic or facsimile withdrawals over the signature of the bidder is mailed and postmarked prior to the specified bid opening time. A bid may be withdrawn in person by a bidder or its authorized representative if, before the exact time set for opening of bids, the identity of the person requesting withdrawal is established and the person signs a receipt for the bid.

## 6. Bid Opening

All bids received by the date and time of receipt specified in the solicitation will be publicly opened and read. The time and place of opening will be as specified in the solicitation. Bidders and other interested persons may be present.

## 7. Service of Protest

(a) Definitions. As used in this provision:

"Interested party" means an actual or prospective bidder whose direct economic interest would be affected by the award of the contract.

"Protest" means a written objection by an interested party to this solicitation or to a proposed or actual award of a contract pursuant to this solicitation.

(b) Protests shall be served on the Contracting Officer by obtaining written and dated acknowledgement from —

[Contracting Officer designate the official or location where a protest may be served on the Contracting Officer]

(c) All protests shall be resolved in accordance with the PHA's/IHA's protest policy and procedures, copies of which are maintained at the PHA/IHA.

## 8. Contract Award

(a) The PHA/IHA will evaluate bids in response to this solicitation without discussions and will award a contract to the responsible bidder whose bid, conforming to the solicitation, will be most advantageous to the PHA/IHA considering only price and any price-related factors specified in the solicitation.

(b) If the apparent low bid received in response to this solicitation exceeds the PHA's/IHA's available funding for the proposed contract work, the PHA/IHA may either accept separately priced items (see 8(e) below) or use the following procedure to determine contract award. The PHA/IHA shall apply in turn to each bid (proceeding in order from the apparent low bid to the high bid) each of the separately priced bid deductible items, if any, in their priority order set forth in this solicitation. If upon the application of the first deductible item to all initial bids, a new low bid is within the PHA's/IHA's available funding, then award shall be made to that bidder. If no bid is within the available funding amount, then the PHA/IHA shall apply the second deductible item. The PHA/IHA shall continue this process until an evaluated low bid, if any, is within the PHA's/IHA's available funding. If upon the application of all deductibles, no bid is within the PHA's/IHA's available funding, or if the solicitation does not request separately priced deductibles, the PHA/IHA shall follow its written policy and procedures in making any award under this solicitation.

(c) In the case of tie low bids, award shall be made in accordance with the PHA's/IHA's written policy and procedures.

(d) The PHA/IHA may reject any and all bids, accept other than the lowest bid (e.g., the apparent low bid is unreasonably low), and waive informalities or minor irregularities in bids received, in accordance with the PHA's/IHA's written policy and procedures.

(e) Unless precluded elsewhere in the solicitation, the PHA/IHA may accept any item or combination of items bid.

(f) The PHA/IHA may reject any bid as nonresponsive if it is materially unbalanced as to the prices for the various items of work to be performed. A bid is materially unbalanced when it is based on prices significantly less than cost for some work and prices which are significantly overstated for other work.

(g) A written award shall be furnished to the successful bidder within the period for acceptance specified in the bid and shall result in a binding contract without further action by either party.

**9. Bid Guarantee (applicable to construction and equipment contracts exceeding \$25,000)**

All bids must be accompanied by a negotiable bid guarantee which shall not be less than five percent (5%) of the amount of the bid. The bid guarantee may be a certified check, bank draft, U.S. Government Bonds at par value, or a bid bond secured by a surety company acceptable to the U.S. Government and authorized to do business in the state where the work is to be performed. In the case where the work under the contract will be performed on an Indian reservation area, the bid guarantee may also be an irrevocable Letter of Credit (see provision 10, Assurance of Completion, below). Certified checks and bank drafts must be made payable to the order of the PHA/IHA. The bid guarantee shall insure the execution of the contract and the furnishing of a method of assurance of completion by the successful bidder as required by the solicitation. Failure to submit a bid guarantee with the bid shall result in the rejection of the bid. Bid guarantees submitted by unsuccessful bidders will be returned as soon as practicable after bid opening.

**10. Assurance of Completion**

(a) Unless otherwise provided in State law, the successful bidder shall furnish an assurance of completion prior to the execution of any contract under this solicitation. This assurance may be [Contracting Officer check applicable items] —

[ ] (1) a performance and payment bond in a penal sum of 100 percent of the contract price; or, as may be required or permitted by State law;

[ ] (2) separate performance and payment bonds, each for 50 percent or more of the contract price;

[ ] (3) a 20 percent cash escrow;

[ ] (4) a 25 percent irrevocable letter of credit; or,

[ ] (5) an irrevocable letter of credit for 10 percent of the total contract price with a monitoring and disbursements agreement with the IHA (applicable only to contracts awarded by an IHA under the Indian Housing Program).

(b) Bonds must be obtained from guarantee or surety companies acceptable to the U.S. Government and authorized to do business in the state where the work is to be performed. Individual sureties will not be considered. U.S. Treasury Circular Number 570, published annually in the Federal Register, lists companies approved to act as sureties on bonds securing Government contracts, the maximum underwriting limits on each contract bonded, and the States in which the company is licensed to do business. Use of companies listed in this circular is mandatory. Copies of the circular may be downloaded on the U.S. Department of Treasury website <http://www.fms.treas.gov/c570/index.html>, or ordered for a minimum fee by contacting the Government Printing Office at (202) 512-2168.

(c) Each bond shall clearly state the rate of premium and the total amount of premium charged. The current power of attorney for the person who signs for the surety company must be attached to the bond. The effective date of the power of attorney shall not precede the date of the bond. The effective date of the bond shall be on or after the execution date of the contract.

(d) Failure by the successful bidder to obtain the required assurance of completion within the time specified, or within such extended period as the PHA/IHA may grant based upon reasons determined adequate by the PHA/IHA, shall render the bidder ineligible for award. The PHA/IHA may then either award the contract to the next lowest responsible bidder or solicit new bids. The PHA/IHA may retain the ineligible bidder's bid guarantee.

**11. Preconstruction Conference (applicable to construction contracts)**

After award of a contract under this solicitation and prior to the start of work, the successful bidder will be required to attend a preconstruction conference with representatives of the PHA/IHA and its architect/engineer, and other interested parties convened by the PHA/IHA. The conference will serve to acquaint the participants with the general plan of the construction operation and all other requirements of the contract (e.g., Equal Employment Opportunity, Labor Standards). The PHA/IHA will provide the successful bidder with the date, time, and place of the conference.

**12. Indian Preference Requirements (applicable only if this solicitation is for a contract to be performed on a project for an Indian Housing Authority)**

(a) HUD has determined that the contract awarded under this solicitation is subject to the requirements of section 7(b) of the Indian Self-Determination and Education Assistance Act (25 U.S.C. 450e(b)). Section 7(b) requires that any contract or subcontract entered into for the benefit of Indians shall require that, to the greatest extent feasible

(1) Preferences and opportunities for training and employment (other than core crew positions; see paragraph (h) below) in connection with the administration of such contracts or subcontracts be given to qualified "Indians." The Act defines "Indians" to mean persons who are members of an Indian tribe and defines "Indian tribe" to mean any Indian tribe, band, nation, or other organized group or community, including any Alaska Native village or regional or village corporation as defined in or established pursuant to the Alaska Native Claims Settlement Act, which is recognized as eligible for the special programs and services provided by the United States to Indians because of their status as Indians; and,

(2) Preference in the award of contracts or subcontracts in connection with the administration of contracts be given to Indian organizations and to Indian-owned economic enterprises, as defined in section 3 of the Indian Financing Act of 1974 (25 U.S.C. 1452). That Act defines "economic enterprise" to mean any Indian-owned commercial, industrial, or business activity established or organized for the purpose of profit, except that the Indian ownership must constitute not less than 51 percent of the enterprise; "Indian organization" to mean the governing body of any Indian tribe or entity established or recognized by such governing body; "Indian" to mean any person who is a member of any tribe, band, group, pueblo, or community which is recognized by the Federal Government as eligible for services from the Bureau of Indian Affairs and any "Native" as defined in the Alaska Native Claims Settlement Act; and Indian "tribe" to mean any Indian tribe, band, group, pueblo, or community including Native villages and Native groups (including

---

corporations organized by Kenai, Juneau, Sitka, and Kodiak) as defined in the Alaska Native Claims Settlement Act, which is recognized by the Federal Government as eligible for services from the Bureau of Indian Affairs.

(b) (1) The successful Contractor under this solicitation shall comply with the requirements of this provision in awarding all subcontracts under the contract and in providing training and employment opportunities.

(2) A finding by the IHA that the contractor, either (i) awarded a subcontract without using the procedure required by the IHA, (ii) falsely represented that subcontracts would be awarded to Indian enterprises or organizations; or, (iii) failed to comply with the contractor's employment and training preference bid statement shall be grounds for termination of the contract or for the assessment of penalties or other remedies.

(c) If specified elsewhere in this solicitation, the IHA may restrict the solicitation to qualified Indian-owned enterprises and Indian organizations. If two or more (or a greater number as specified elsewhere in the solicitation) qualified Indian-owned enterprises or organizations submit responsive bids, award shall be made to the qualified enterprise or organization with the lowest responsive bid. If fewer than the minimum required number of qualified Indian-owned enterprises or organizations submit responsive bids, the IHA shall reject all bids and readvertise the solicitation in accordance with paragraph (d) below.

(d) If the IHA prefers not to restrict the solicitation as described in paragraph (c) above, or if after having restricted a solicitation an insufficient number of qualified Indian enterprises or organizations submit bids, the IHA may advertise for bids from non-Indian as well as Indian-owned enterprises and Indian organizations. Award shall be made to the qualified Indian enterprise or organization with the lowest responsive bid if that bid is -

(1) Within the maximum HUD-approved budget amount established for the specific project or activity for which bids are being solicited; and

(2) No more than the percentage specified in 24 CFR 905.175(c) higher than the total bid price of the lowest responsive bid from any qualified bidder. If no responsive bid by a qualified Indian-owned economic enterprise or organization is within the stated range of the total bid price of the lowest responsive bid from any qualified enterprise, award shall be made to the bidder with the lowest bid.

(e) Bidders seeking to qualify for preference in contracting or subcontracting shall submit proof of Indian ownership with their bids. Proof of Indian ownership shall include but not be limited to:

(1) Certification by a tribe or other evidence that the bidder is an Indian. The IHA shall accept the certification of a tribe that an individual is a member.

(2) Evidence such as stock ownership, structure, management, control, financing and salary or profit sharing arrangements of the enterprise.

(f) (1) All bidders must submit with their bids a statement describing how they will provide Indian preference in the award of subcontracts. The specific requirements of that statement and the factors to be used by the IHA in determining the statement's adequacy are included as an attachment to this solicitation. Any bid that fails to include the required statement shall be rejected as nonresponsive. The IHA may require that comparable statements be provided by subcontractors to the successful Contractor, and may require the Contractor to reject any bid or proposal by a subcontractor that fails to include the statement.

(2) Bidders and prospective subcontractors shall submit a certification (supported by credible evidence) to the IHA in any instance where the bidder or subcontractor believes it is infeasible to provide Indian preference in subcontracting. The acceptance or rejection by the IHA of the certification shall be final. Rejection shall disqualify the bid from further consideration.

(g) All bidders must submit with their bids a statement detailing their employment and training opportunities and their plans to provide preference to Indians in implementing the contract; and the number or percentage of Indians anticipated to be employed and trained. Comparable statements from all proposed subcontractors must be submitted. The criteria to be used by the IHA in determining the statement(s)'s adequacy are included as an attachment to this solicitation. Any bid that fails to include the required statement(s), or that includes a statement that does not meet minimum standards required by the IHA shall be rejected as nonresponsive.

(h) Core crew employees. A core crew employee is an individual who is a bona fide employee of the contractor at the time the bid is submitted; or an individual who was not employed by the bidder at the time the bid was submitted, but who is regularly employed by the bidder in a supervisory or other key skilled position when work is available. Bidders shall submit with their bids a list of all core crew employees.

(i) Preference in contracting, subcontracting, employment, and training shall apply not only on-site, on the reservation, or within the IHA's jurisdiction, but also to contracts with firms that operate outside these areas (e.g., employment in modular or manufactured housing construction facilities).

(j) Bidders should contact the IHA to determine if any additional local preference requirements are applicable to this solicitation.

(k) The IHA [ ] does [ ] does not [Contracting Officer check applicable box] maintain lists of Indian-owned economic enterprises and Indian organizations by specialty (e.g., plumbing, electrical, foundations), which are available to bidders to assist them in meeting their responsibility to provide preference in connection with the administration of contracts and subcontracts.

# General Conditions for Construction Contracts - Public Housing Programs

U.S. Department of Housing and Urban  
Development  
Office of Public and Indian Housing  
OMB Approval No. 2577-0157 (exp. 1/31/2027)

**Applicability. This form is applicable to any  
construction/development contract greater than \$250,000.**

Public reporting burden for this collection of information is estimated to average 1.0 hours per response, including the time for reviewing instructions, searching existing data sources, gathering and maintaining the data needed, and completing and reviewing the collection of information. Comments regarding the accuracy of this burden estimate and any suggestions for reducing this burden can be sent to the Reports Management Officer, Office of Policy Development and Research, REE, Department of Housing and Urban Development, 451 7th St SW, Room 4176, Washington, DC 20410-5000. When providing comments, please refer to OMB Approval No. 2577-0157. This form includes those clauses required by OMB's common rule on grantee procurement, implemented at HUD in 2 CFR 200, and those requirements set forth in Section 3 of the Housing and Urban Development Act of 1968 and its amendment by the Housing and Community Development Act of 1992, implemented by HUD at 24 CFR Part 75. The form is required for construction contracts awarded by Public Housing Agencies (PHAs). The form is used by Housing Authorities in solicitations to provide necessary contract clauses. If the form were not used, PHAs would be unable to enforce their contracts. Responses to the collection of information are required to obtain a benefit or to retain a benefit. The information requested does not lend itself to confidentiality. HUD may not conduct or sponsor, and a person is not required to respond to a collection of information unless it displays a currently valid OMB number.

Clause		Page	Clause		Page
1.	Definitions	2	<b>Administrative Requirements</b>		
2.	Contractor's Responsibility for Work	2	25.	Contract Period	9
3.	Architect's Duties, Responsibilities and Authority	2	26.	Order of Precedence	9
4.	Other Contracts	3	27.	Payments	9
	<b>Construction Requirements</b>		28.	Contract Modifications	10
5.	Preconstruction Conference and Notice to Proceed	3	29.	Changes	10
6.	Construction Progress Schedule	3	30.	Suspension of Work	11
7.	Site Investigation and Conditions Affecting the Work	3	31.	Disputes	11
8.	Differing Site Conditions	4	32.	Default	11
9.	Specifications and Drawings for Construction	4	33.	Liquidated	12
10.	As-Built Drawings	5	34.	Termination of Convenience	12
11.	Material and Workmanship	5	35.	Assignment of Contract	12
12.	Permits and Codes	5	36.	Insurance	12
13.	Health, Safety, and Accident Prevention	6	37.	Subcontracts	13
14.	Temporary Buildings and Transportation Materials	6	38.	Subcontracting with Small and Minority Firms, Women's Business Enterprise, and Labor Surplus Area Firms	13
15.	Availability and Use of Utility Services	6	39.	Equal Employment Opportunity	13
16.	Protection of Existing Vegetation, Structures, Equipment, Utilities, and Improvements	6	40.	Employment, Training, and Contracting Opportunities for Low-Income Persons, Section 3 of the Housing and Urban Development Act of 1968	14
17.	Temporary Buildings and Transportation Materials	7	41.	Interest of Members of Congress	15
18.	Clean Air and Water	7	42.	Interest of Members, Officers, or Employees and Former Members, Officers, or Employees	15
19.	Energy Efficiency	7	43.	Limitations on Payments Made to Influence	15
20.	Inspection and Acceptance of Construction	7	44.	Royalties and Patents	15
21.	Use and Possession Prior to	8	45.	Examination and Retention of Contractor's Records	15
22.	Warranty of Title	8	46.	Labor Standards-Davis-Bacon and Related Acts	15
23.	Warranty of	8	47.	Non-Federal Prevailing Wage Rates	19
24.	Prohibition Against	9	48.	Procurement of Recovered	19
	Liens			Materials	

---

## 1. Definitions

- (a) "Architect" means the person or other entity engaged by the PHA to perform architectural, engineering, design, and other services related to the work as provided for in the contract. When a PHA uses an engineer to act in this capacity, the terms "architect" and "engineer" shall be synonymous. The Architect shall serve as a technical representative of the Contracting Officer. The Architect's authority is as set forth elsewhere in this contract.
- (b) "Contract" means the contract entered into between the PHA and the Contractor. It includes the forms of Bid, the Bid Bond, the Performance and Payment Bond or Bonds or other assurance of completion, the Certifications, Representations, and Other Statements of Bidders (form HUD-5370), these General Conditions of the Contract for Construction (form HUD-5370), the applicable wage rate determinations from the U.S. Department of Labor, any special conditions included elsewhere in the contract, the specifications, and drawings. It includes all formal changes to any of those documents by addendum, change order, or other modification.
- (c) "Contracting Officer" means the person delegated the authority by the PHA to enter into, administer, and/or terminate this contract and designated as such in writing to the Contractor. The term includes any successor Contracting Officer and any duly authorized representative of the Contracting Officer also designated in writing. The Contracting Officer shall be deemed the authorized agent of the PHA in all dealings with the Contractor.
- (d) "Contractor" means the person or other entity entering into the contract with the PHA to perform all of the work required under the contract.
- (e) "Drawings" means the drawings enumerated in the schedule of drawings contained in the Specifications and as described in the contract clause entitled Specifications and Drawings for Construction herein.
- (f) "HUD" means the United States of America acting through the Department of Housing and Urban Development including the Secretary, or any other person designated to act on its behalf. HUD has agreed, subject to the provisions of an Annual Contributions Terms and Conditions (ACC), to provide financial assistance to the PHA, which includes assistance in financing the work to be performed under this contract. As defined elsewhere in these General Conditions or the contract documents, the determination of HUD may be required to authorize changes in the work or for release of funds to the PHA for payment to the Contractor. Notwithstanding HUD's role, nothing in this contract shall be construed to create any contractual relationship between the Contractor and HUD.
- (g) "Project" means the entire project, whether construction or rehabilitation, the work for which is provided for in whole or in part under this contract.
- (h) "PHA" means the Public Housing Agency organized under applicable state laws which is a party to this contract.
- (j) "Specifications" means the written description of the technical requirements for construction and includes the criteria and tests for determining whether the requirements are met.
- (l) "Work" means materials, workmanship, and manufacture and fabrication of components.

## 2. Contractor's Responsibility for Work

- (a) The Contractor shall furnish all necessary labor, materials, tools, equipment, and transportation necessary for performance of the work. The Contractor shall also furnish all necessary water, heat, light, and power not made available to the Contractor by the PHA pursuant to the clause entitled Availability and Use of Utility Services herein.
- (b) The Contractor shall perform on the site, and with its own organization, work equivalent to at least [ ] (12 percent unless otherwise indicated) of the total amount of work to be performed under the order. This percentage may be reduced by a supplemental agreement to this order if, during performing the work, the Contractor requests a reduction and the Contracting Officer determines that the reduction would be to the advantage of the PHA.
- (c) At all times during performance of this contract and until the work is completed and accepted, the Contractor shall directly superintend the work or assign and have on the work site a competent superintendent who is satisfactory to the Contracting Officer and has authority to act for the Contractor.
- (d) The Contractor shall be responsible for all damages to persons or property that occur as a result of the Contractor's fault or negligence, and shall take proper safety and health precautions to protect the work, the workers, the public, and the property of others. The Contractor shall hold and save the PHA, its officers and agents, free and harmless from liability of any nature occasioned by the Contractor's performance. The Contractor shall also be responsible for all materials delivered and work performed until completion and acceptance of the entire work, except for any completed unit of work which may have been accepted under the contract.
- (e) The Contractor shall lay out the work from base lines and bench marks indicated on the drawings and be responsible for all lines, levels, and measurements of all work executed under the contract. The Contractor shall verify the figures before laying out the work and will be held responsible for any error resulting from its failure to do so.
- (f) The Contractor shall confine all operations (including storage of materials) on PHA premises to areas authorized or approved by the Contracting Officer.
- (g) The Contractor shall at all times keep the work area, including storage areas, free from accumulations of waste materials. After completing the work and before final inspection, the Contractor shall (1) remove from the premises all scaffolding, equipment, tools, and materials (including rejected materials) that are not the property of the PHA and all rubbish caused by its work; (2) leave the work area in a clean, neat, and orderly condition satisfactory to the Contracting Officer; (3) perform all specified tests; and, (4) deliver the installation in complete and operating condition.
- (h) The Contractor's responsibility will terminate when all work has been completed, the final inspection made, and the work accepted by the Contracting Officer. The Contractor will then be released from further obligation except as required by the warranties specified elsewhere in the contract.

## 3. Architect's Duties, Responsibilities, and Authority

- (a) The Architect for this contract, and any successor, shall be designated in writing by the Contracting Officer.

- (b) The Architect shall serve as the Contracting Officer's technical representative with respect to architectural, **Schedule** engineering, and design matters related to the work performed under the contract. The Architect may provide direction on contract performance. Such direction shall be within the scope of the contract and may not be of a nature which: (1) institutes additional work outside the scope of the contract; (2) constitutes a change as defined in the Changes clause herein; (3) causes an increase or decrease in the cost of the contract; (4) alters the Construction Progress Schedule; or (5) changes any of the other express terms or conditions of the contract.
- (c) The Architect's duties and responsibilities may include but shall not be limited to:
- (1) Making periodic visits to the work site, and on the basis of his/her on-site inspections, issuing written reports to the PHA which shall include all observed deficiencies. The Architect shall file a copy of the report with the Contractor's designated representative at the site;
  - (2) Making modifications in drawings and technical specifications and assisting the Contracting Officer in the preparation of change orders and other contract modifications for issuance by the Contracting Officer;
  - (3) Reviewing and making recommendations with respect to - (i) the Contractor's construction progress schedules; (ii) the Contractor's shop and detailed drawings; (iii) the machinery, mechanical and other equipment and materials or other articles proposed for use by the Contractor; and, (iv) the Contractor's price breakdown and progress payment estimates; and,
  - (4) Assisting in inspections, signing Certificates of Completion, and making recommendations with respect to acceptance of work completed under the contract.

#### 4. Other Contracts

The PHA may undertake or award other contracts for additional work at or near the site of the work under this contract. The Contractor shall fully cooperate with the other contractors and with PHA employees and shall carefully adapt scheduling and performing the work under this contract to accommodate the additional work, heeding any direction that may be provided by the Contracting Officer. The Contractor shall not commit or permit any act that will interfere with the performance of work by any other contractor or by PHA employees

### Construction Requirements

#### 5. Pre-construction Conference and Notice to Proceed

of the work, and that it has investigated and satisfied itself

- (a) Within ten calendar days of contract execution, and prior to the commencement of work, the Contractor shall attend a preconstruction conference with representatives of the PHA, its Architect, and other interested parties convened by the PHA. The conference will serve to acquaint the participants with the general plan of the construction operation and all other requirements of the contract. The PHA will provide the Contractor with the date, time, and place of the conference.
- (b) The contractor shall begin work upon receipt of a written Notice to Proceed from the Contracting Officer or designee. The Contractor shall not begin work prior to receiving such notice.

#### 6. Construction Progress

- (a) The Contractor shall, within five days after the work commences on the contract or another period of time determined by the Contracting Officer, prepare and submit to the Contracting Officer for approval three copies of a practicable schedule showing the order in which the Contractor proposes to perform the work, and the dates on which the Contractor contemplates starting and completing the several salient features of the work (including acquiring labor, materials, and equipment). The schedule shall be in the form of a progress chart of suitable scale to indicate appropriately the percentage of work scheduled for completion by any given date during the period. If the Contractor fails to submit a schedule within the time prescribed, the Contracting Officer may withhold approval of progress payments or take other remedies under the contract until the Contractor submits the required schedule.
- (b) The Contractor shall enter the actual progress on the chart as required by the Contracting Officer, and immediately deliver three copies of the annotated schedule to the Contracting Officer. If the Contracting Officer determines, upon the basis of inspection conducted pursuant to the clause entitled Inspection and Acceptance of Construction, herein that the Contractor is not meeting the approved schedule, the Contractor shall take steps necessary to improve its progress, including those that may be required by the Contracting Officer, without additional cost to the PHA. In this circumstance, the Contracting Officer may require the Contractor to increase the number of shifts, overtime operations, days of work, and/or the amount of construction plant, and to submit for approval any supplementary schedule or schedules in chart form as the Contracting Officer deems necessary to demonstrate how the approved rate of progress will be regained.
- (c) Failure of the Contractor to comply with the requirements of the Contracting Officer under this clause shall be grounds for a determination by the Contracting Officer that the Contractor is not prosecuting the work with sufficient diligence to ensure completion within the time specified in the Contract. Upon making this determination, the Contracting Officer may terminate the Contractor's right to proceed with the work, or any separable part of it, in accordance with the Default clause of this contract.

#### 7. Site Investigation and Conditions Affecting the Work

- (a) The Contractor acknowledges that it has taken steps reasonably necessary to ascertain the nature and location as to the general and local conditions which can affect the work or its cost, including but not limited to, (1) conditions bearing upon transportation, disposal, handling, and storage of materials; (2) the availability of labor, water, electric power, and roads; (3) uncertainties of weather, river stages, tides, or similar physical conditions at the site; (4) the conformation and conditions of the ground; and (5) the character of equipment and facilities needed preliminary to and during work performance. The Contractor also acknowledges that it has satisfied itself as to the character, quality, and quantity of surface and subsurface materials or obstacles to be encountered insofar as this information is

reasonably ascertainable from an inspection of the site, including all exploratory work done by the PHA, as well as from the drawings and specifications made a part of this contract. Any failure of the Contractor to take the actions described and acknowledged in this paragraph will not relieve the Contractor from responsibility for estimating properly the difficulty and cost of successfully performing the work, or for proceeding to successfully perform the work without additional expense to the PHA.

- (b) The PHA assumes no responsibility for any conclusions or interpretations made by the Contractor based on the information made available by the PHA. Nor does the PHA assume responsibility for any understanding reached or representation made concerning conditions which can affect the work by any of its officers or agents before the execution of this contract, unless that understanding or representation is expressly stated in this contract.

## 8. Differing Site Conditions

(a) The Contractor shall promptly, and before the conditions are disturbed, give a written notice to the Contracting Officer of (1) subsurface or latent physical conditions at the site which differ materially from those indicated in this contract, or (2) unknown physical conditions at the site(s), of an unusual nature, which differ materially from those ordinarily encountered and generally recognized as inhering in work of the character provided for in the contract.

(b) The Contracting Officer shall investigate the site conditions promptly after receiving the notice. Work shall not proceed at the affected site, except at the

Contractor's risk, until the Contracting Officer has provided written instructions to the Contractor. If the conditions do materially so differ and cause an increase or decrease in the Contractor's cost of, or the time required for, performing any part of the work under this contract, whether or not changed as a result of the conditions, the Contractor shall file a claim in writing to the PHA within ten days after receipt of such instructions and, in any event, before proceeding with the work. An equitable adjustment in the contract price, the delivery schedule, or both shall be made under this clause and the contract modified in writing accordingly.

(c) No request by the Contractor for an equitable adjustment to the contract under this clause shall be allowed, unless the Contractor has given the written notice required; provided, that the time prescribed in (a) above for giving written notice may be extended by the Contracting Officer.

(d) No request by the Contractor for an equitable adjustment to the contract for differing site conditions shall be allowed if made after final payment under this contract.

## 9. Specifications and Drawings for Construction

(a) The Contractor shall keep on the work site a copy of the drawings and specifications and shall at all times give the Contracting Officer access thereto. Anything mentioned in the specifications and not shown on the drawings, or shown on the drawings and not mentioned in the specifications, shall be of like effect as if shown or mentioned in both. In case of difference between drawings and specifications, the specifications shall govern. In case of discrepancy in the figures, in the drawings, or in the specifications, the matter shall be

promptly submitted to the Contracting Officer, who shall promptly make a determination in writing. Any adjustment by the Contractor without such a determination shall be at its own risk and expense. The Contracting Officer shall furnish from time to time such detailed drawings and other information as considered necessary, unless otherwise provided.

(b) Wherever in the specifications or upon the drawings the words "directed", "required", "ordered", "designated", "prescribed", or words of like import are used, it shall be understood that the "direction", "requirement", "order", "designation", or "prescription", of the Contracting Officer is intended and similarly the words "approved", "acceptable", "satisfactory", or words of like import shall mean "approved by", or "acceptable to", or "satisfactory to" the Contracting Officer, unless otherwise expressly stated.

(c) Where "as shown" "as indicated", "as detailed", or words of similar import are used, it shall be understood that the reference is made to the drawings accompanying this contract unless stated otherwise. The word "provided" as used herein shall be understood to mean "provide complete in place" that is "furnished and installed".

(d) "Shop drawings" means drawings, submitted to the PHA by the Contractor, subcontractor, or any lower tier subcontractor, showing in detail (1) the proposed fabrication and assembly of structural elements and (2) the installation (i.e., form, fit, and attachment details) of materials of equipment. It includes drawings, diagrams, layouts, schematics, descriptive literature, illustrations, schedules, performance and test data, and similar materials furnished by the Contractor to explain in detail specific portions of the work required by the contract. The PHA may duplicate, use, and disclose in any manner and for any purpose shop drawings delivered under this contract.

(e) If this contract requires shop drawings, the Contractor shall coordinate all such drawings, and review them for accuracy, completeness, and compliance with other contract requirements and shall indicate its approval thereon as evidence of such coordination and review. Shop drawings submitted to the Contracting Officer without evidence of the Contractor's approval may be returned for resubmission. The Contracting Officer will indicate an approval or disapproval of the shop drawings and if not approved as submitted shall indicate the PHA's reasons therefore. Any work done before such approval shall be at the Contractor's risk. Approval by the Contracting Officer shall not relieve the Contractor from responsibility for any errors or omissions in such drawings, nor from responsibility for complying with the requirements of this contract, except with respect to variations described and approved in accordance with (f) below.

(f) If shop drawings show variations from the contract requirements, the Contractor shall describe such variations in writing, separate from the drawings, at the time of submission. If the Architect approves any such variation and the Contracting Officer concurs, the Contracting Officer shall issue an appropriate modification to the contract, except that, if the variation is minor or does not involve a change in price or in time of performance, a modification need not be issued.

(g) It shall be the responsibility of the Contractor to make timely requests of the PHA for such large scale and full size drawings, color schemes, and other additional information, not already in his possession, which shall be

required in the planning and production of the work. Such requests may be submitted as the need arises, but each such request shall be filed in ample time to permit appropriate action to be taken by all parties involved so as to avoid delay.

- (h) The Contractor shall submit to the Contracting Officer for approval four copies (unless otherwise indicated) of all shop drawings as called for under the various headings of these specifications. Three sets (unless otherwise indicated) of all shop drawings, will be retained by the PHA and one set will be returned to the Contractor. As required by the Contracting Officer, the Contractor, upon completing the work under this contract, shall furnish a complete set of all shop drawings as finally approved. These drawings shall show all changes and revisions made up to the time the work is completed and accepted.
- (i) This clause shall be included in all subcontracts at any tier. It shall be the responsibility of the Contractor to ensure that all shop drawings prepared by subcontractors are submitted to the Contracting Officer.

#### 10. As-Built Drawings

- (a) "As-built drawings," as used in this clause, means drawings submitted by the Contractor or subcontractor at any tier to show the construction of a particular structure or work as actually completed under the contract. "As-built drawings" shall be synonymous with "Record drawings."
- (b) As required by the Contracting Officer, the Contractor shall provide the Contracting Officer accurate information to be used in the preparation of permanent as-built drawings. For this purpose, the Contractor shall record on one set of contract drawings all changes from the installations originally indicated, and record final locations of underground lines by depth from finish grade and by accurate horizontal offset distances to permanent surface improvements such as buildings, curbs, or edges of walks.
- (c) This clause shall be included in all subcontracts at any tier. It shall be the responsibility of the Contractor to ensure that all as-built drawings prepared by subcontractors are submitted to the Contracting Officer.

#### 11. Material and Workmanship

- (a) All equipment, material, and articles furnished under this contract shall be new and of the most suitable grade for the purpose intended, unless otherwise specifically provided in this contract. References in the contract to equipment, material, articles, or patented processes by trade name, make, or catalog number, shall be regarded as establishing a standard of quality and shall not be construed as limiting competition. The Contractor may, at its option, use any equipment, material, article, or process that, in the judgment of, and as approved by the Contracting Officer, is equal to that named in the specifications, unless otherwise specifically provided in this contract.
- (b) Approval of equipment and materials.
- (1) The Contractor shall obtain the Contracting Officer's approval of the machinery and mechanical and other equipment to be incorporated into the work. When requesting approval, the Contractor shall furnish to the Contracting Officer the name of the manufacturer, the model number, and other information concerning the performance, capacity, nature, and rating of the

machinery and mechanical and other equipment. When required by this contract or by the Contracting Officer, the Contractor shall also obtain the Contracting Officer's approval of the material or articles which the Contractor contemplates incorporating into the work. When requesting approval, the Contractor shall provide full information concerning the material or articles. Machinery, equipment, material, and articles that do not have the required approval shall be installed or used at the risk of subsequent rejection.

- (2) When required by the specifications or the Contracting Officer, the Contractor shall submit appropriately marked samples (and certificates related to them) for approval at the Contractor's expense, with all shipping charges prepaid. The Contractor shall label, or otherwise properly mark on the container, the material or product represented, its place of origin, the name of the producer, the Contractor's name, and the identification of the construction project for which the material or product is intended to be used.
- (3) Certificates shall be submitted in triplicate, describing each sample submitted for approval and certifying that the material, equipment or accessory complies with contract requirements. The certificates shall include the name and brand of the product, name of manufacturer, and the location where produced.
- (4) Approval of a sample shall not constitute a waiver of the PHA right to demand full compliance with contract requirements. Materials, equipment and accessories may be rejected for cause even though samples have been approved.
- (5) Wherever materials are required to comply with recognized standards or specifications, such specifications shall be accepted as establishing the technical qualities and testing methods, but shall not govern the number of tests required to be made nor modify other contract requirements. The Contracting Officer may require laboratory test reports on items submitted for approval or may approve materials on the basis of data submitted in certificates with samples. Check tests will be made on materials delivered for use only as frequently as the Contracting Officer determines necessary to insure compliance of materials with the specifications. The Contractor will assume all costs of retesting materials which fail to meet contract requirements and/or testing materials offered in substitution for those found deficient.
- (6) After approval, samples will be kept in the Project office until completion of work. They may be built into the work after a substantial quantity of the materials they represent has been built in and accepted.
- (c) Requirements concerning lead-based paint. The Contractor shall comply with the requirements concerning lead-based paint contained in the Lead-Based Paint Poisoning Prevention Act (42 U.S.C. 4821-4846) as implemented by 24 CFR Part 35.

#### 12. Permits and Codes

- (a) The Contractor shall give all notices and comply with all applicable laws, ordinances, codes, rules and regulations. Notwithstanding the requirement of the Contractor to comply with the drawings and specifications in the contract, all work installed shall comply with all applicable codes and regulations as amended by any

waivers. Before installing the work, the Contractor shall examine the drawings and the specifications for compliance with applicable codes and regulations bearing on the work and shall immediately report any discrepancy it may discover to the Contracting Officer.

Where the requirements of the drawings and specifications fail to comply with the applicable code or regulation, the Contracting Officer shall modify the contract by change order pursuant to the clause entitled Changes herein to conform to the code or regulation.

- (b) The Contractor shall secure and pay for all permits, fees, and licenses necessary for the proper execution and completion of the work. Where the PHA can arrange for the issuance of all or part of these permits, fees and licenses, without cost to the Contractor, the contract amount shall be reduced accordingly.

### 13. Health, Safety, and Accident Prevention

(a) In performing this contract, the Contractor shall:

- (1) Ensure that no laborer or mechanic shall be required to work in surroundings or under working conditions which are unsanitary, hazardous, or dangerous to his/her health and/or safety as determined under construction safety and health standards promulgated by the Secretary of Labor by regulation;
- (2) Protect the lives, health, and safety of other persons;
- (3) Prevent damage to property, materials, supplies, and equipment; and,
- (4) Avoid work interruptions.

(b) For these purposes, the Contractor shall:

- (1) Comply with regulations and standards issued by the Secretary of Labor at 29 CFR Part 1926. Failure to comply may result in imposition of sanctions pursuant to the Contract Work Hours and Safety Standards Act (Public Law 91-54, 83 Stat. 96), 40 U.S.C. 3701 et seq.; and
- (2) Include the terms of this clause in every subcontract so that such terms will be binding on each subcontractor.

(c) The Contractor shall maintain an accurate record of exposure data on all accidents incident to work performed under this contract resulting in death, traumatic injury, occupational disease, or damage to property, materials, supplies, or equipment, and shall report this data in the manner prescribed by 29 CFR Part 1904.

(d) The Contracting Officer shall notify the Contractor of any noncompliance with these requirements and of the corrective action required. This notice, when delivered to the Contractor or the Contractor's representative at the site of the work, shall be deemed sufficient notice of the noncompliance and corrective action required. After receiving the notice, the Contractor shall immediately take corrective action. If the Contractor fails or refuses to take corrective action promptly, the Contracting Officer may issue an order stopping all or part of the work until satisfactory corrective action has been taken. The Contractor shall not base any claim or request for equitable adjustment for additional time or money on any stop order issued under these circumstances.

(e) The Contractor shall be responsible for its subcontractors' compliance with the provisions of this clause. The Contractor shall take such action with respect to any subcontract as the PHA, the Secretary of Housing and Urban Development, or the Secretary of Labor shall direct as a means of enforcing such provisions.

### 14. Temporary Heating

The Contractor shall provide and pay for temporary heating, covering, and enclosures necessary to properly protect all work and materials against damage by dampness and cold, to dry out the work, and to facilitate the completion of the work. Any permanent heating equipment used shall be turned over to the PHA in the condition and at the time required by the specifications.

### 15. Availability and Use of Utility Services

(a) The PHA shall make all reasonably required amounts of utilities available to the Contractor from existing outlets and supplies, as specified in the contract. Unless otherwise provided in the contract, the amount of each utility service consumed shall be charged to or paid for by the Contractor at prevailing rates charged to the PHA or, where the utility is produced by the PHA, at reasonable rates determined by the Contracting Officer. The Contractor shall carefully conserve any utilities furnished without charge.

(b) The Contractor, at its expense and in a manner satisfactory to the Contracting Officer, shall install and maintain all necessary temporary connections and distribution lines, and all meters required to measure the amount of each utility used for the purpose of determining charges. Before final acceptance of the work by the PHA, the Contractor shall remove all the temporary connections, distribution lines, meters, and associated paraphernalia.

### 16. Protection of Existing Vegetation, Structures, Equipment, Utilities, and Improvements

(a) The Contractor shall preserve and protect all structures, equipment, and vegetation (such as trees, shrubs, and grass) on or adjacent to the work site, which are not to be removed under this contract, and which do not unreasonably interfere with the work required under this contract.

(b) The Contractor shall only remove trees when specifically authorized to do so, and shall avoid damaging vegetation that will remain in place. If any limbs or branches of trees are broken during performance of this contract, or by the careless operation of equipment, or by workmen, the Contractor shall trim those limbs or branches with a clean cut and paint the cut with a tree-pruning compound as directed by the Contracting Officer.

(c) The Contractor shall protect from damage all existing improvements and utilities (1) at or near the work site and (2) on adjacent property of a third party, the locations of which are made known to or should be known by the Contractor. Prior to disturbing the ground at the construction site, the Contractor shall ensure that all underground utility lines are clearly marked.

(d) The Contractor shall shore up, brace, underpin, secure, and protect as necessary all foundations and other parts of existing structures adjacent to, adjoining, and in the vicinity of the site, which may be affected by the excavations or other operations connected with the construction of the project.

(e) Any equipment temporarily removed as a result of work under this contract shall be protected, cleaned, and replaced in the same condition as at the time of award of this contract.

- (f) New work which connects to existing work shall correspond in all respects with that to which it connects and/or be similar to existing work unless otherwise required by the specifications.
- (g) No structural members shall be altered or in any way weakened without the written authorization of the Contracting Officer, unless such work is clearly specified in the plans or specifications.
- (h) If the removal of the existing work exposes discolored or unfinished surfaces, or work out of alignment, such surfaces shall be refinished, or the material replaced as necessary to make the continuous work uniform and harmonious. This, however, shall not be construed to require the refinishing or reconstruction of dissimilar finishes previously exposed, or finished surfaces in good condition, but in different planes or on different levels **Construction** when brought together by the removal of intervening work, unless such refinishing or reconstruction is specified in the plans or specifications.
- (i) The Contractor shall give all required notices to any adjoining or adjacent property owner or other party before the commencement of any work.
- (j) The Contractor shall indemnify and save harmless the PHA from any damages on account of settlement or the loss of lateral support of adjoining property, any damages from changes in topography affecting drainage, and from all loss or expense and all damages for which the PHA may become liable in consequence of such injury or damage to adjoining and adjacent structures and their premises.
- (k) The Contractor shall repair any damage to vegetation, structures, equipment, utilities, or improvements, including those that are the property of a third party, resulting from failure to comply with the requirements of this contract or failure to exercise reasonable care in performing the work. If the Contractor fails or refuses to repair the damage promptly, the Contracting Officer may have the necessary work performed and charge the cost to the Contractor.

## 17. Temporary Buildings and Transportation of Materials

- (a) Temporary buildings (e.g., storage sheds, shops, offices, sanitary facilities) and utilities may be erected by the Contractor only with the approval of the Contracting Officer and shall be built with labor and materials furnished by the Contractor without expense to the PHA. The temporary buildings and utilities shall remain the property of the Contractor and shall be removed by the Contractor at its expense upon completion of the work. With the written consent of the Contracting Officer, the buildings and utilities may be abandoned and need not be removed.
- (b) The Contractor shall, as directed by the Contracting Officer, use only established roadways, or use temporary roadways constructed by the Contractor when and as authorized by the Contracting Officer. When materials are transported in prosecuting the work, vehicles shall not be loaded beyond the loading capacity recommended by the manufacturer of the vehicle or prescribed by any federal, state, or local law or regulation. When it is necessary to cross curbs or sidewalks, the Contractor shall protect them from damage. The Contractor shall repair or pay for the repair of any damaged curbs, sidewalks, or roads.

## 18. Clean Air and Water

The contractor shall comply with the Clean Air Act, as amended, 42 USC 7401 et seq., the Federal Water Pollution Control Water Act, as amended, 33 U.S.C. 1251 et seq., and standards issued pursuant thereto in the facilities in which this contract is to be performed.

## 19. Energy Efficiency

The Contractor shall comply with mandatory standards and policies relating to energy efficiency which are contained in the energy conservation plan issued in compliance with the Energy Policy and Conservation Act (Pub.L. 94-163) for the State in which the work under the contract is performed.

## 20. Inspection and Acceptance of

- (a) Definitions. As used in this clause -
- (1) "Acceptance" means the act of an authorized representative of the PHA by which the PHA approves and assumes ownership of the work performed under this contract. Acceptance may be partial or complete.
- (2) "Inspection" means examining and testing the work performed under the contract (including, when appropriate, raw materials, equipment, components, and intermediate assemblies) to determine whether it conforms to contract requirements.
- (3) "Testing" means that element of inspection that determines the properties or elements, including functional operation of materials, equipment, or their components, by the application of established scientific principles and procedures.
- (b) The Contractor shall maintain an adequate inspection system and perform such inspections as will ensure that the work performed under the contract conforms to contract requirements. All work is subject to PHA inspection and test at all places and at all reasonable times before acceptance to ensure strict compliance with the terms of the contract.
- (c) PHA inspections and tests are for the sole benefit of the PHA and do not: (1) relieve the Contractor of responsibility for providing adequate quality control measures; (2) relieve the Contractor of responsibility for loss or damage of the material before acceptance; (3) constitute or imply acceptance; or, (4) affect the continuing rights of the PHA after acceptance of the completed work under paragraph (j) below.
- (d) The presence or absence of the PHA inspector does not relieve the Contractor from any contract requirement, nor is the inspector authorized to change any term or condition of the specifications without the Contracting Officer's written authorization. All instructions and approvals with respect to the work shall be given to the Contractor by the Contracting Officer.
- (e) The Contractor shall promptly furnish, without additional charge, all facilities, labor, and material reasonably needed for performing such safe and convenient inspections and tests as may be required by the Contracting Officer. The PHA may charge to the Contractor any additional cost of inspection or test when work is not ready at the time specified by the Contractor for inspection or test, or when prior rejection makes reinspection or retest necessary. The PHA shall perform all inspections and tests in a manner that will not unnecessarily delay the work. Special, full size, and performance tests shall be performed as described in the contract.

- (f) The PHA may conduct routine inspections of the construction site on a daily basis.
- (g) The Contractor shall, without charge, replace or correct work found by the PHA not to conform to contract requirements, unless the PHA decides that it is in its interest to accept the work with an appropriate adjustment in contract price. The Contractor shall promptly segregate and remove rejected material from the premises.
- (h) If the Contractor does not promptly replace or correct rejected work, the PHA may (1) by contract or otherwise, replace or correct the work and charge the cost to the Contractor, or (2) terminate for default the Contractor's right to proceed.
- (i) If any work requiring inspection is covered up without approval of the PHA, it must, if requested by the Contracting Officer, be uncovered at the expense of the Contractor. If at any time before final acceptance of the entire work, the **Construction PHA** considers it necessary or advisable, to examine work already completed by removing or tearing it out, the Contractor, shall on request, promptly furnish all necessary facilities, labor, and material. If such work is found to be defective or nonconforming in any material respect due to the fault of the Contractor or its subcontractors, the Contractor shall defray all the expenses of the examination and of satisfactory reconstruction. If, however, such work is found to meet the requirements of the contract, the Contracting Officer shall make an equitable adjustment to cover the cost of the examination and reconstruction, including, if completion of the work was thereby delayed, an extension of time.
- (j) The Contractor shall notify the Contracting Officer, in writing, as to the date when in its opinion all or a designated portion of the work will be substantially completed and ready for inspection. If the Architect determines that the state of preparedness is as represented, the PHA will promptly arrange for the inspection. Unless otherwise specified in the contract, the PHA shall accept, as soon as practicable after completion and inspection, all work required by the contract or that portion of the work the Contracting Officer determines and designates can be accepted separately. Acceptance shall be final and conclusive except for latent defects, fraud, gross mistakes amounting to fraud, or the PHA's right under any warranty or guarantee.

## 21. Use and Possession Prior to Completion

- (a) The PHA shall have the right to take possession of or use any completed or partially completed part of the work. Before taking possession of or using any work, the Contracting Officer shall furnish the Contractor a list of items of work remaining to be performed or corrected on those portions of the work that the PHA intends to take possession of or use. However, failure of the Contracting Officer to list any item of work shall not relieve the Contractor of responsibility for complying with the terms of the contract. The PHA's possession or use shall not be deemed an acceptance of any work under the contract.
- (b) While the PHA has such possession or use, the Contractor shall be relieved of the responsibility for (1) the loss of or damage to the work resulting from the PHA's possession or use, notwithstanding the terms of the clause entitled Permits and Codes herein; (2) all maintenance costs on the areas occupied; and, (3) furnishing heat, light, power, and water used in the areas

occupied without proper remuneration therefore. If prior possession or use by the PHA delays the progress of the work or causes additional expense to the Contractor, an equitable adjustment shall be made in the contract price or the time of completion, and the contract shall be modified in writing accordingly.

## 22. Warranty of Title

The Contractor warrants good title to all materials, supplies, and equipment incorporated in the work and agrees to deliver the premises together with all improvements thereon free from any claims, liens or charges, and agrees further that neither it nor any other person, firm or corporation shall have any right to a lien upon the premises or anything appurtenant thereto.

## 23. Warranty of

- (a) In addition to any other warranties in this contract, the Contractor warrants, except as provided in paragraph (j) of this clause, that work performed under this contract conforms to the contract requirements and is free of any defect in equipment, material, or workmanship performed by the Contractor or any subcontractor or supplier at any tier. This warranty shall continue for a period of \_\_\_\_\_ (one year unless otherwise indicated) from the date of final acceptance of the work. If the PHA takes possession of any part of the work before final acceptance, this warranty shall continue for a period of (one year unless otherwise indicated) from the date that the PHA takes possession.
- (b) The Contractor shall remedy, at the Contractor's expense, any failure to conform, or any defect. In addition, the Contractor shall remedy, at the Contractor's expense, any damage to PHA-owned or controlled real or personal property when the damage is the result of—
- (1) The Contractor's failure to conform to contract requirements; or
  - (2) Any defects of equipment, material, workmanship or design furnished by the Contractor.
- (c) The Contractor shall restore any work damaged in fulfilling the terms and conditions of this clause. The Contractor's warranty with respect to work repaired or replaced will run for (one year unless otherwise indicated) from the date of repair or replacement.
- (d) The Contracting Officer shall notify the Contractor, in writing, within a reasonable time after the discovery of any failure, defect or damage.
- (e) If the Contractor fails to remedy any failure, defect, or damage within a reasonable time after receipt of notice, the PHA shall have the right to replace, repair or otherwise remedy the failure, defect, or damage at the Contractor's expense.
- (f) With respect to all warranties, express or implied, from subcontractors, manufacturers, or suppliers for work performed and materials furnished under this contract, the Contractor shall:
- (1) Obtain all warranties that would be given in normal commercial practice;
  - (2) Require all warranties to be executed in writing, for the benefit of the PHA; and,
  - (3) Enforce all warranties for the benefit of the PHA.
- (g) In the event the Contractor's warranty under paragraph (a) of this clause has expired, the PHA may bring suit at its own expense to enforce a subcontractor's, manufacturer's or supplier's warranty.

- (h) Unless a defect is caused by the negligence of the Contractor or subcontractor or supplier at any tier, the Contractor shall not be liable for the repair of any defect of material or design furnished by the PHA nor for the repair of any damage that results from any defect in PHA furnished material or design.
- (i) Notwithstanding any provisions herein to the contrary, the establishment of the time periods in paragraphs (a) and (c) above relate only to the specific obligation of the Contractor to correct the work, and have no relationship to the time within which its obligation to comply with the contract may be sought to be enforced, nor to the time within which proceedings may be commenced to establish the Contractor's liability with respect to its obligation other than specifically to correct the work.
- (j) This warranty shall not limit the PHA's rights under the Inspection and Acceptance of Construction clause of this contract with respect to latent defects, gross mistakes or fraud.

**24. Prohibition Against Liens**

The Contractor is prohibited from placing a lien on the PHA's property. This prohibition shall apply to all subcontractors at any tier and all materials suppliers.

**Administrative Requirements**

**25. Contract Period**

this contract within \_\_\_\_\_ calendar days of the effective date of the contract, or within the time schedule established in the notice to proceed issued by the Contracting Officer.

**26. Order of Provisions**

accordance with the terms and conditions of the

In the event of a conflict between these General Conditions and the Specifications, the General Conditions shall prevail. In the event of a conflict between the contract and any applicable state or local law or regulation, the state or local law or regulation shall prevail; provided that such state or local law or regulation does not conflict with, or is less restrictive than applicable federal law, regulation, or Executive Order. In the event of such a conflict, applicable federal law, regulation, and Executive Order shall prevail.

**27. Payments**

retain ten (10) percent of the amount of progress

- (a) The PHA shall pay the Contractor the price as provided in this contract.
- (b) The PHA shall make progress payments approximately every 30 days as the work proceeds, on estimates of work accomplished which meets the standards of quality established under the contract, as approved by the Contracting Officer. The PHA may, subject to written determination and approval of the Contracting Officer, make more frequent payments to contractors which are qualified small businesses.
- (c) Before the first progress payment under this contract, the Contractor shall furnish, in such detail as requested by the Contracting Officer, a breakdown of the total contract price showing the amount included therein for each principal category of the work, which shall substantiate the payment amount requested in order to provide a

basis for determining progress payments. The breakdown shall be approved by the Contracting Officer and must be acceptable to HUD. If the contract covers more than one project, the Contractor shall furnish a separate breakdown for each. The values and quantities employed in making up this breakdown are for determining the amount of progress payments and shall not be construed as a basis for additions to or deductions from the contract price. The Contractor shall prorate its overhead and profit over the construction period of the contract.

- (d) The Contractor shall submit, on forms provided by the PHA, periodic estimates showing the value of the work performed during each period based upon the approved submitted not later than \_\_\_\_\_ days in advance of the date set for payment and are subject to correction and revision as required. The estimates must be approved by the Contracting Officer with the concurrence of the Architect prior to payment. If the contract covers more than one project, the Contractor shall furnish a separate progress payment estimate for each.
- (e) Along with each request for progress payments and the required estimates, the Contractor shall furnish the following certification, or payment shall not be made: I hereby certify, to the best of my knowledge and belief, that:

- (1) The amounts requested are only for performance in accordance with the specifications, terms, and conditions of the contract;
- (2) Payments to subcontractors and suppliers have been made from previous payments received under the contract, and timely payments will be made from the proceeds of the payment covered by this certification, in accordance with subcontract agreements; and,
- (3) This request for progress payments does not include any amounts which the prime contractor intends to withhold or retain from a subcontractor or supplier in subcontract.

**Name:**

Title:

Date:

- (f) Except as otherwise provided in State law, the PHA shall payments until completion and acceptance of all work under the contract; except, that if upon completion of 50 percent of the work, the Contracting Officer, after consulting with the Architect, determines that the Contractor's performance and progress are satisfactory, the PHA may make the remaining payments in full for the work subsequently completed. If the Contracting Officer subsequently determines that the Contractor's performance and progress are unsatisfactory, the PHA shall reinstate the ten (10) percent (or other percentage as provided in State law) retainage until such time as the Contracting Officer determines that performance and progress are satisfactory.
- (g) The Contracting Officer may authorize material delivered on the site and preparatory work done to be taken into consideration when computing progress payments.

Material delivered to the Contractor at locations other than the site may also be taken into consideration if the Contractor furnishes satisfactory evidence that (1) it has acquired title to such material; (2) the material is properly stored in a bonded warehouse, storage yard, or similar suitable place as may be approved by the Contracting Officer; (3) the material is insured to cover its full value; and (4) the material will be used to perform this contract. Before any progress payment which includes delivered material is made, the Contractor shall furnish such documentation as the Contracting Officer may require to assure the protection of the PHA's interest in such materials. The Contractor shall remain responsible for such stored material notwithstanding the transfer of title to the PHA.

- (h) All material and work covered by progress payments made shall, at the time of payment become the sole property of the PHA, but this shall not be construed as (1) relieving the Contractor from the sole responsibility for all material and work upon which payments have been made or the restoration of any damaged work; or, (2) waiving the right of the PHA to require the fulfillment of all of the terms of the contract. In the event the work of the Contractor has been damaged by other contractors or persons other than employees of the PHA in the course of their employment, the Contractor shall restore such damaged work without cost to the PHA and to seek redress for its damage only from those who directly caused it.
- (i) The PHA shall make the final payment due the Contractor under this contract after (1) completion and final acceptance of all work; and (2) presentation of release of all claims against the PHA arising by virtue of this contract, other than claims, in stated amounts, that the Contractor has specifically excepted from the operation of the release. Each such exception shall embrace no more than one claim, the basis and scope of which shall be clearly defined. The amounts for such excepted claims shall not be included in the request for final payment. A release may also be required of the assignee if the Contractor's claim to amounts payable under this contract has been assigned.
- (j) Prior to making any payment, the Contracting Officer may require the Contractor to furnish receipts or other evidence of payment from all persons performing work and supplying material to the Contractor, if the Contracting Officer determines such evidence is necessary to substantiate claimed costs.
- (k) The PHA shall not; (1) determine or adjust any claims for payment or disputes arising there under between the Contractor and its subcontractors or material suppliers; or, (2) withhold any moneys for the protection of the subcontractors or material suppliers. The failure or refusal of the PHA to withhold moneys from the Contractor shall in nowise impair the obligations of any surety or sureties under any bonds furnished under this contract.

## 28. Contract Modifications

- (a) Only the Contracting Officer has authority to modify any term or condition of this contract. Any contract modification shall be authorized in writing.
- (b) The Contracting Officer may modify the contract unilaterally (1) pursuant to a specific authorization stated in a contract clause (e.g., Changes); or (2) for administrative matters which do not change the rights or

responsibilities of the parties (e.g., change in the PHA address). All other contract modifications shall be in the form of supplemental agreements signed by the Contractor and the Contracting Officer.

- (c) When a proposed modification requires the approval of HUD prior to its issuance (e.g., a change order that exceeds the PHA's approved threshold), such modification shall not be effective until the required approval is received by the PHA.

## 29. Changes

- (a) The Contracting Officer may, at any time, without notice to the sureties, by written order designated or indicated to be a change order, make changes in the work within the general scope of the contract including changes:
  - (1) In the specifications (including drawings and designs);
  - (2) In the method or manner of performance of the work;
  - (3) PHA-furnished facilities, equipment, materials, services, or site; or,
  - (4) Directing the acceleration in the performance of the work.
- (b) Any other written order or oral order (which, as used in this paragraph (b), includes direction, instruction, interpretation, or determination) from the Contracting Officer that causes a change shall be treated as a change order under this clause; provided, that the Contractor gives the Contracting Officer written notice stating (1) the date, circumstances and source of the order and (2) that the Contractor regards the order as a change order.
- (c) Except as provided in this clause, no order, statement or conduct of the Contracting Officer shall be treated as a change under this clause or entitle the Contractor to an equitable adjustment.
- (d) If any change under this clause causes an increase or decrease in the Contractor's cost of, or the time required for the performance of any part of the work under this contract, whether or not changed by any such order, the Contracting Officer shall make an equitable adjustment and modify the contract in writing. However, except for an adjustment based on defective specifications, no proposal for any change under paragraph (b) above shall be allowed for any costs incurred more than 20 days (5 days for oral orders) before the Contractor gives written notice as required. In the case of defective specifications for which the PHA is responsible, the equitable adjustment shall include any increased cost reasonably incurred by the Contractor in attempting to comply with the defective specifications.
- (e) The Contractor must assert its right to an adjustment under this clause within 30 days after (1) receipt of a written change order under paragraph (a) of this clause, or (2) the furnishing of a written notice under paragraph (b) of this clause, by submitting a written statement describing the general nature and the amount of the proposal. If the facts justify it, the Contracting Officer may extend the period for submission. The proposal may be included in the notice required under paragraph (b) above. No proposal by the Contractor for an equitable adjustment shall be allowed if asserted after final payment under this contract.
- (f) The Contractor's written proposal for equitable adjustment shall be submitted in the form of a lump sum proposal supported with an itemized breakdown of all increases and decreases in the contract in at least the following details:

- (1) Direct Costs. Materials (list individual items, the quantity and unit cost of each, and the aggregate cost); Transportation and delivery costs associated with materials; Labor breakdowns by hours or unit costs (identified with specific work to be performed); Construction equipment exclusively necessary for the change; Costs of preparation and/ or revision to shop drawings resulting from the change; Worker's Compensation and Public Liability Insurance; Employment taxes under FICA and FUTA; and, Bond Costs when size of change warrants revision.
- (2) Indirect Costs. Indirect costs may include overhead, general and administrative expenses, and fringe benefits not normally treated as direct costs.
- (3) Profit. The amount of profit shall be negotiated and may vary according to the nature, extent, and complexity of the work required by the change. The allowability of the direct and indirect costs shall be determined in accordance with the Contract Cost Principles and Procedures for Commercial Firms in Part 31 of the Federal Acquisition Regulation (48 CFR 1-31), as implemented by HUD Handbook 2210.18, in effect on the date of this contract. The Contractor shall not be allowed a profit on the profit received by any subcontractor. Equitable adjustments for deleted work shall include a credit for profit and may include a credit for indirect costs. On proposals covering both increases and decreases in the amount of the contract, the application of indirect costs and profit shall be on the net-change in direct costs for the Contractor or subcontractor performing the work.
- (g) The Contractor shall include in the proposal its request for time extension (if any), and shall include sufficient information and dates to demonstrate whether and to what extent the change will delay the completion of the contract in its entirety.
- (h) The Contracting Officer shall act on proposals within 30 days after their receipt, or notify the Contractor of the date when such action will be taken.
- (i) Failure to reach an agreement on any proposal shall be a dispute under the clause entitled Disputes herein. Nothing in this clause, however, shall excuse the Contractor from proceeding with the contract as changed.
- (j) Except in an emergency endangering life or property, no change shall be made by the Contractor without a prior order from the Contracting Officer.

### 30. Suspension of Work

- (a) The Contracting Officer may order the Contractor in writing to suspend, delay, or interrupt all or any part of the work of this contract for the period of time that the Contracting Officer determines appropriate for the convenience of the PHA.
- (b) If the performance of all or any part of the work is, for an unreasonable period of time, suspended, delayed, or interrupted (1) by an act of the Contracting Officer in the administration of this contract, or (2) by the Contracting Officer's failure to act within the time specified (or within a reasonable time if not specified) in this contract an adjustment shall be made for any increase in the cost of performance of the contract (excluding profit) necessarily caused by such unreasonable suspension, delay, or interruption and the contract modified in writing accordingly. However, no adjustment shall be made under this clause for any suspension, delay, or interruption to the extent that performance would have

- been so suspended, delayed, or interrupted by any other cause, including the fault or negligence of the Contractor or for which any equitable adjustment is provided for or excluded under any other provision of this contract.
- (c) A claim under this clause shall not be allowed (1) for any costs incurred more than 20 days before the Contractor shall have notified the Contracting Officer in writing of the act or failure to act involved (but this requirement shall not apply as to a claim resulting from a suspension order); and, (2) unless the claim, in an amount stated, is asserted in writing as soon as practicable after the termination of the suspension, delay, or interruption, but not later than the date of final payment under the contract.

### 31. Disputes

- (a) "Claim," as used in this clause, means a written demand or written assertion by one of the contracting parties seeking, as a matter of right, the payment of money in a sum certain, the adjustment or interpretation of contract terms, or other relief arising under or relating to the contract. A claim arising under the contract, unlike a claim relating to the contract, is a claim that can be resolved under a contract clause that provides for the relief sought by the claimant. A voucher, invoice, or other routine request for payment that is not in dispute when submitted is not a claim. The submission may be converted to a claim by complying with the requirements of this clause, if it is disputed either as to liability or amount or is not acted upon in a reasonable time.
- (b) Except for disputes arising under the clauses entitled Labor Standards - Davis Bacon and Related Acts, herein, all disputes arising under or relating to this contract, including any claims for damages for the alleged breach thereof which are not disposed of by agreement, shall be resolved under this clause.
- (c) All claims by the Contractor shall be made in writing and submitted to the Contracting Officer for a written decision. A claim by the PHA against the Contractor shall be subject to a written decision by the Contracting Officer.
- (d) The Contracting Officer shall, within 60 (unless otherwise indicated) days after receipt of the request, decide the claim or notify the Contractor of the date by which the decision will be made.
- (e) The Contracting Officer's decision shall be final unless the Contractor (1) appeals in writing to a higher level in the PHA in accordance with the PHA's policy and procedures, (2) refers the appeal to an independent mediator or arbitrator, or (3) files suit in a court of competent jurisdiction. Such appeal must be made within (30 unless otherwise indicated) days after receipt of the Contracting Officer's decision.
- (f) The Contractor shall proceed diligently with performance of this contract, pending final resolution of any request for relief, claim, appeal, or action arising under or relating to the contract, and comply with any decision of the Contracting Officer.

### 32. Default

- (a) If the Contractor refuses or fails to prosecute the work, or any separable part thereof, with the diligence that will insure its completion within the time specified in this contract, or any extension thereof, or fails to complete said work within this time, the Contracting Officer may, by written notice to the Contractor, terminate the right to

proceed with the work (or separable part of the work) that has been delayed. In this event, the PHA may take over the work and complete it, by contract or otherwise, and may take possession of and use any materials, equipment, and plant on the work site necessary for completing the work. The Contractor and its sureties shall be liable for any damage to the PHA resulting from the **Convenience** Contractor's refusal or failure to complete the work within the specified time, whether or not the Contractor's right to proceed with the work is terminated. This liability includes any increased costs incurred by the PHA in completing the work.

- (b) The Contractor's right to proceed shall not be terminated or the Contractor charged with damages under this clause if—
- (1) The delay in completing the work arises from unforeseeable causes beyond the control and without the fault or negligence of the Contractor. Examples of such causes include (i) acts of God, or of the public enemy, (ii) acts of the PHA or other governmental entity in either its sovereign or contractual capacity, (iii) acts of another contractor in the performance of a contract with the PHA, (iv) fires, (v) floods, (vi) epidemics, (vii) quarantine restrictions, (viii) strikes, (ix) freight embargoes, (x) unusually severe weather, or (xi) delays of subcontractors or suppliers at any tier arising from unforeseeable causes beyond the control and without the fault or negligence of both the Contractor and the subcontractors or suppliers; and
- (2) The Contractor, within days (10 days unless otherwise indicated) from the beginning of such delay (unless extended by the Contracting Officer) notifies the Contracting Officer in writing of the causes of delay. The Contracting Officer shall ascertain the facts and the extent of the delay. If, in the judgment of the Contracting Officer, the findings of fact warrant such action, time for completing the work shall be extended by written modification to the contract. The findings of the Contracting Officer shall be reduced to a written decision which shall be subject to the provisions of the Disputes clause of this contract.
- (c) If, after termination of the Contractor's right to proceed, it is determined that the Contractor was not in default, or that the delay was excusable, the rights and obligations of the parties will be the same as if the termination had been for convenience of the PHA.

### 33. Liquidated Damages

- (a) If the Contractor fails to complete the work within the time specified in the contract, or any extension, as specified in the clause entitled Default of this contract, the Contractor shall pay to the PHA as liquidated damages, the sum of \$ \_\_\_\_\_ [Contracting Officer insert amount] for each day of delay. If different completion dates are specified in the contract for separate parts or stages of the work, the amount of liquidated damages shall be assessed on those parts or stages which are delayed. To the extent that the Contractor's delay or nonperformance is excused under another clause in this contract, liquidated damages shall not be due the PHA. The Contractor remains liable for damages caused other than by delay.
- (b) If the PHA terminates the Contractor's right to proceed, the resulting damage will consist of liquidated damages until such reasonable time as may be required for final

completion of the work together with any increased costs occasioned the PHA in completing the work.

- (c) If the PHA does not terminate the Contractor's right to proceed, the resulting damage will consist of liquidated damages until the work is completed or accepted.

### 34. Termination for

- (a) The Contracting Officer may terminate this contract in whole, or in part, whenever the Contracting Officer determines that such termination is in the best interest of the PHA. Any such termination shall be effected by delivery to the Contractor of a Notice of Termination specifying the extent to which the performance of the work under the contract is terminated, and the date upon which such termination becomes effective.
- (b) If the performance of the work is terminated, either in whole or in part, the PHA shall be liable to the Contractor for reasonable and proper costs resulting from such termination upon the receipt by the PHA of a properly presented claim setting out in detail: (1) the total cost of the work performed to date of termination less the total amount of contract payments made to the Contractor; (2) the cost (including reasonable profit) of settling and paying claims under subcontracts and material orders for work performed and materials and supplies delivered to the site, payment for which has not been made by the PHA to the Contractor or by the Contractor to the subcontractor or supplier; (3) the cost of preserving and protecting the work already performed until the PHA or assignee takes possession thereof or assumes responsibility therefore; (4) the actual or estimated cost of legal and accounting services reasonably necessary to prepare and present the termination claim to the PHA; and (5) an amount constituting a reasonable profit on the value of the work performed by the Contractor.
- (c) The Contracting Officer will act on the Contractor's claim within days (60 days unless otherwise indicated) of receipt of the Contractor's claim.
- (d) Any disputes with regard to this clause are expressly made subject to the provisions of the Disputes clause of this contract.

### 35. Assignment of Contract

The Contractor shall not assign or transfer any interest in this contract; except that claims for monies due or to become due from the PHA under the contract may be assigned to a bank, trust company, or other financial institution. Such assignments of claims shall only be made with the written concurrence of the Contracting Officer. If the Contractor is a partnership, this contract shall inure to the benefit of the surviving or remaining member(s) of such partnership as approved by the Contracting Officer.

### 36. Insurance

- (a) Before commencing work, the Contractor and each subcontractor shall furnish the PHA with certificates of insurance showing the following insurance is in force and will insure all operations under the Contract:
- (1) Workers' Compensation, in accordance with state or Territorial Workers' Compensation laws.
- (2) Commercial General Liability with a combined single limit for bodily injury and property damage of not less than \$ \_\_\_\_\_ [Contracting Officer insert amount]

per occurrence to protect the Contractor and each subcontractor against claims for bodily injury or death and damage to the property of others. This shall cover the use of all equipment, hoists, and vehicles on the site(s) not covered by Automobile Liability under (3) below. If the Contractor has a "claims made" policy, then the following additional requirements apply: the policy must provide a "retroactive date" which must be on or before the execution date of the Contract; and the extended reporting period may not be less than five years following the completion date of the Contract.

- (3) Automobile Liability on owned and non-owned motor vehicles used on the site(s) or in connection therewith for a combined single limit for bodily injury and property damage of not less than \$ \_\_\_\_\_

[Contracting Officer insert amount] per occurrence.

- (b) Before commencing work, the Contractor shall furnish the PHA with a certificate of insurance evidencing that Builder's Risk (fire and extended coverage) Insurance on all work in place and/or materials stored at the building site(s), including foundations and building equipment, is in force. The Builder's Risk Insurance shall be for the benefit of the Contractor and the PHA as their interests may appear and each shall be named in the policy or policies as an insured. The Contractor in installing equipment supplied by the PHA shall carry insurance on such equipment from the time the Contractor takes possession thereof until the Contract work is accepted by the PHA. The Builder's Risk Insurance need not be carried on excavations, piers, footings, or foundations until such time as work on the superstructure is started. It need not be carried on landscape work. Policies shall furnish coverage at all times for the full cash value of all completed construction, as well as materials in place and/or stored at the site(s), whether or not partial payment has been made by the PHA. The Contractor may terminate this insurance on buildings as of the date taken over for occupancy by the PHA. The Contractor is not required to carry Builder's Risk Insurance for modernization work which does not involve structural alterations or additions and where the PHA's existing fire and extended coverage policy can be endorsed to include such work.
- (c) All insurance shall be carried with companies which are financially responsible and admitted to do business in the State in which the project is located. If any such insurance is due to expire during the construction period, the Contractor (including subcontractors, as applicable) shall not permit the coverage to lapse and shall furnish evidence of coverage to the Contracting Officer. All certificates of insurance, as evidence of coverage, shall provide that no coverage may be canceled or non-renewed by the insurance company until at least 30 days prior written notice has been given to the Contracting Officer.

### 37. Subcontracts

- (a) Definitions. As used in this contract -
- (1) "Subcontract" means any contract, purchase order, or other purchase agreement, including modifications and change orders to the foregoing, entered into by a subcontractor to furnish supplies, materials, equipment, and services for the performance of the prime contract or a subcontract.

- (2) "Subcontractor" means any supplier, vendor, or firm that furnishes supplies, materials, equipment, or services to or for the Contractor or another subcontractor.
- (b) The Contractor shall not enter into any subcontract with any subcontractor who has been temporarily denied participation in a HUD program or who has been suspended or debarred from participating in contracting programs by any agency of the United States Government or of the state in which the work under this contract is to be performed.
- (c) The Contractor shall be as fully responsible for the acts or omissions of its subcontractors, and of persons either directly or indirectly employed by them as for the acts or omissions of persons directly employed by the Contractor.
- (d) The Contractor shall insert appropriate clauses in all subcontracts to bind subcontractors to the terms and conditions of this contract insofar as they are applicable to the work of subcontractors.
- (e) Nothing contained in this contract shall create any contractual relationship between any subcontractor and the PHA or between the subcontractor and HUD.

### 38. Subcontracting with Small and Minority Firms, Women's Business Enterprise, and Labor Surplus Area Firms

The Contractor shall take the following steps to ensure that, whenever possible, subcontracts are awarded to small business firms, minority firms, women's business enterprises, and labor surplus area firms:

- (a) Placing qualified small and minority businesses and women's business enterprises on solicitation lists;
- (b) Ensuring that small and minority businesses and women's business enterprises are solicited whenever they are potential sources;
- (c) Dividing total requirements, when economically feasible, into smaller tasks or quantities to permit maximum participation by small and minority businesses and women's business enterprises;
- (d) Establishing delivery schedules, where the requirements of the contract permit, which encourage participation by small and minority businesses and women's business enterprises; and
- (e) Using the services and assistance of the U.S. Small Business Administration, the Minority Business Development Agency of the U.S. Department of Commerce, and State and local governmental small business agencies.

### 39. Equal Employment Opportunity

During the performance of this contract, the Contractor/Seller agrees as follows:

- (a) The Contractor/Seller shall not discriminate against any employee or applicant for employment because of race color, religion, sex, sexual orientation, gender identity, disability, or national origin.
- (b) The Contractor/Seller shall take affirmative action to ensure that applicants are employed, and that employees are treated during employment without regard to their race, color, religion, sex, sexual orientation, gender identity, disability, or national origin. Such action shall include, but not be limited to, (1) employment, (2) upgrading demotion, (4) transfer, (5) recruitment or recruitment advertising, (6) layoff or termination, (7) rates of pay or other forms of compensation, and (8) selection for training, including apprenticeship

(c) The Contractor/Seller agrees to post in conspicuous places available to employees and applicants for employment the notices to be provided by the Contracting Officer setting forth the provisions of this nondiscrimination clause.

(d) The Contractor/Seller shall, in all solicitations or advertisements for employees placed by or on behalf of the Contractor/Seller, state that all qualified applicants will receive consideration for employment without regard to race, color, religion, sex, or national origin.

(e) The Contractor/Seller shall send, to each labor union or representative of workers with which it has a collective bargaining agreement or other contract or understanding, the notice to be provided by the Contracting Officer advising the labor union or workers' representative of the Contractor's commitments under this clause, and post copies of the notice in conspicuous places available to employees and applicants for employment.

(f) The Contractor/Seller shall comply with Executive Order 11246, as amended, and the rules, regulations, and orders of the Secretary of Labor.

(g) The Contractor/Seller shall furnish all information and reports required by Executive Order 11246, as amended, Section 503 of the Rehabilitation Act of 1973, as amended, and by rules, regulations, and orders of the Secretary of Labor, or pursuant thereto. The Contractor/Seller shall permit

access to its books, records, and accounts by the Secretary of Labor for purposes of investigation to ascertain compliance with such rules, regulations, and orders.

(h) In the event of a that the Contractor/Seller is in noncompliance with the nondiscrimination clauses of this contract or with any of such rules, regulations, or orders, this contract may be canceled, terminated or suspended in whole or in part and the contractor/seller may be declared ineligible for further Government contracts in accordance with procedures authorized in Executive Order 11246 of September 24, 1965, and such other sanctions may be imposed and remedies invoked as provided in Executive Order 11246 of September 24, 1965, or by rule, regulation, or order of the Secretary of Labor, or as otherwise provided by law.

(i) The contractor/seller will include the provisions of paragraphs (a) through (h) in every subcontract or purchase order unless exempted by rules, regulations, or orders of the Secretary of Labor issued pursuant to section 204 of Executive Order 11246 of September 24, 1965, so that such provisions will be binding upon each sub[contractor/seller] or vendor. The [contractor/seller] will take such action with respect to any subcontract or purchase order as may be directed by the Secretary of Labor as a means of enforcing such provisions including sanctions for noncompliance: Provided, however, that in the event the [contractor/seller] becomes involved in, or is threatened with, litigation with a subcontractor or vendor as a result of such direction, the [contractor/seller] may request the United States to enter into such litigation to protect the interests of the United States.

(j) Compliance with the requirements of this clause shall be to the maximum extent consistent with, but not in derogation of, compliance with section 7(b) of the Indian Self-Determination and Education Assistance Act and the Indian Preference clause of this contract.

#### **40. Employment, Training, and Contracting Opportunities for Low-Income Persons, Section 3 of the Housing and Urban Development Act of 1968.**

(a) The work to be performed under this contract is subject to the requirements of Section 3 of the Housing and Urban Development Act of 1968, as amended, 12 U.S.C. 1701u (section 3). The purpose of section 3 is to ensure that employment and other economic opportunities generated by HUD assistance or HUD-assisted projects covered by Section 3, shall, to the greatest extent feasible, be directed to low- and very low-income persons, particularly persons who are recipients of HUD assistance for housing.

(b) The parties to this contract agree to comply with HUD's regulations in 24 CFR Part 75, which implement Section 3. As evidenced by their execution of this contract, the parties to this contract certify that they are under no contractual or other impediment that would prevent them from complying with the Part 75 regulations.

(c) The contractor agrees to send to each labor organization or representative of workers with which the contractor has a collective bargaining agreement or other understanding, if any, a notice advising the labor organization or workers' representative of the contractor's commitments under this section 3 clause and will post copies of the notice in conspicuous places at the work site where both employees and applicants for training and employment positions can see the notice. The notice shall describe the Section 3 prioritization requirements and shall state the minimum percentages of labor hour requirements established in the Benchmark Notice (FR-6085-N-04).

(d) The contractor agrees to include this section 3 clause in every subcontract subject to compliance with regulations in 24 CFR Part 75, and agrees to take appropriate action, as provided in an applicable provision of the subcontract or in this section 3 clause, upon a finding that the subcontractor is in violation of the regulations in 24 CFR Part 75. The contractor will not subcontract with any subcontractor where the contractor has notice or knowledge that the subcontractor has been found in violation of the regulations in 24 CFR Part 75.

(e) Noncompliance with HUD's regulations in 24 CFR Part 75 may result in sanctions, termination of this contract for default, and debarment or suspension from future HUD assisted contracts.

(f) Contracts, subcontracts, grants, or subgrants subject to Section 7(b) of the Indian Self-Determination and Education Assistance Act (25 U.S.C. 5307(b)) or subject to tribal preference requirements as authorized under 101(k) of the Native American Housing Assistance and Self-Determination Act (25 U.S.C. 4111(k)) must provide preferences in employment, training, and business opportunities to Indians and Indian organizations, and are therefore not subject to the requirements of 24 CFR Part 75.

---

#### 41. Interest of Members of Congress

No member of or delegate to the Congress of the United States of America shall be admitted to any share or part of this contract or to any benefit that may arise therefrom.

#### 42. Interest of Members, Officers, or Employees and Former Members, Officers, or Employees

No member, officer, or employee of the PHA, no member of the governing body of the locality in which the project is situated, no member of the governing body of the locality in which the PHA was activated, and no other public official of such locality or localities who exercises any functions or responsibilities with respect to the project, shall, during his or her tenure, or for one year thereafter, have any interest, direct or indirect, in this contract or the proceeds thereof.

#### 43. Limitations on Payments made to Influence Certain Federal Financial Transactions

- (a) The Contractor agrees to comply with Section 1352 of Title 31, United States Code which prohibits the use of **Acts** Federal appropriated funds to pay any person for influencing or attempting to influence an officer or employee of any agency, a Member of Congress, and officer or employee of Congress, or an employee of a Member of Congress in connection with any of the following covered Federal actions: the awarding of any Federal contract; the making of any Federal grant; the making of any Federal loan; the entering into of any cooperative agreement; or the modification of any Federal contract, grant, loan, or cooperative agreement.
- (b) The Contractor further agrees to comply with the requirement of the Act to furnish a disclosure (OMB Standard Form LLL, Disclosure of Lobbying Activities) if any funds other than Federal appropriated funds (including profit or fee received under a covered Federal transaction) have been paid, or will be paid, to any person for influencing or attempting to influence an officer or employee of any agency, a Member of Congress, an officer or employee of Congress, or an employee of a Member of Congress in connection with a Federal contract, grant, loan, or cooperative agreement.

#### 44. Royalties and Patents

The Contractor shall pay all royalties and license fees. It shall defend all suits or claims for infringement of any patent rights and shall save the PHA harmless from loss on account thereof; except that the PHA shall be responsible for all such loss when a particular design, process or the product of a particular manufacturer or manufacturers is specified and the Contractor has no reason to believe that the specified design, process, or product is an infringement. If, however, the Contractor has reason to believe that any design, process or product specified is an infringement of a patent, the Contractor shall promptly notify the Contracting Officer. Failure to give such notice shall make the Contractor responsible for resultant loss.

#### 45. Examination and Retention of Contractor's Records

- (a) The PHA, HUD, or Comptroller General of the United States, or any of their duly authorized representatives shall, until 3 years after final payment under this contract, have access to and the right to examine any of the Contractor's directly pertinent books, documents, papers, or other records involving transactions related to this contract for the purpose of making audit, examination, excerpts, and transcriptions.
- (b) The Contractor agrees to include in first-tier subcontracts under this contract a clause substantially the same as paragraph (a) above. "Subcontract," as used in this clause, excludes purchase orders not exceeding \$10,000.
- (c) The periods of access and examination in paragraphs (a) and (b) above for records relating to (1) appeals under the Disputes clause of this contract, (2) litigation or settlement of claims arising from the performance of this contract, or (3) costs and expenses of this contract to which the PHA, HUD, or Comptroller General or any of their duly authorized representatives has taken exception shall continue until disposition of such appeals, litigation, claims, or exceptions.

#### 46. Labor Standards - Davis-Bacon and Related

If the total amount of this contract exceeds \$2,000, the Federal labor standards set forth in the clause below shall apply to the development or construction work to be performed under the contract.

- (a) Minimum Wages.
  - (1) All laborers and mechanics employed under this contract in the development or construction of the project(s) involved will be paid unconditionally and not less often than once a week, and without subsequent deduction or rebate on any account (except such payroll deductions as are permitted by regulations issued by the Secretary of Labor under the Copeland Act (29 CFR Part 3)), the full amount of wages and bona fide fringe benefits (or cash equivalents thereof) due at time of payment computed at rates not less than those contained in the wage determination of the Secretary of Labor which is attached hereto and made a part hereof, regardless of any contractual relationship which may be alleged to exist between the Contractor and such laborers and mechanics. Contributions made or costs reasonably anticipated for bona fide fringe benefits under Section 1(b)(2) of the Davis-Bacon Act on behalf of laborers or mechanics are considered wages paid to such laborers or mechanics, subject to the provisions of 29 CFR 5.5(a)(1)(iv); also, regular contributions made or costs incurred for more than a weekly period (but not less often than quarterly) under plans, funds, or programs which cover the regular weekly period, are deemed to be constructively made or incurred during such weekly period. Such laborers and mechanics shall be paid the appropriate wage rate and fringe benefits in the wage determination for the classification of work actually performed, without regard to skill, except as provided in 29 CFR 5.5(a)(4). Laborers or mechanics performing work in more than one classification may be compensated at the rate specified for each classification for the time actually worked therein; provided, that the employer's payroll records accurately set forth the time spent in each classification in which work is performed. The wage determination (including any additional classification and wage rates conformed under 29 CFR 5.5(a)(1)(ii) and the Davis-Bacon poster (WH-1321) shall

be posted at all times by the Contractor and its subcontractors at the site of the work in a prominent and accessible place where it can be easily seen by the workers.

(2) (i) Any class of laborers or mechanics, including

helpers, which is not listed in the wage determination and which is to be employed under the contract shall be classified in conformance with the wage determination. HUD shall approve an additional classification and wage rate and fringe benefits therefor only when all the following criteria have been met: (A) The work to be performed by the classification requested is not performed by a classification in the wage determination; and (B) The classification is utilized in the area by the construction industry; and (C) The proposed wage rate, including any bona fide fringe benefits, bears a reasonable relationship to the wage rates contained in the wage determination.

- (ii) If the Contractor and the laborers and mechanics to be employed in the classification (if known), or their representatives, and HUD or its designee agree on the classification and wage rate (including the amount designated for fringe benefits where appropriate), a report of the action taken shall be sent by HUD or its designee to the Administrator of the Wage and Hour Division, Employee Standards Administration, U.S. Department of Labor, Washington, DC 20210. The Administrator, or an authorized representative, will approve, modify, or disapprove every additional classification action within 30 days of receipt and so advise HUD or its designee or will notify HUD or its designee within the 30-day period that additional time is necessary.
- (iii) In the event the Contractor, the laborers or mechanics to be employed in the classification or their representatives, and HUD or its designee do not agree on the proposed classification and wage rate (including the amount designated for fringe benefits, where appropriate), HUD or its designee shall refer the questions, including the views of all interested parties and the recommendation of HUD or its designee, to the Administrator of the Wage and Hour Division for determination. The Administrator, or an authorized representative, will issue a determination within 30 days of receipt and so advise HUD or its designee or will notify HUD or its designee within the 30-day period that additional time is necessary.
- (iv) The wage rate (including fringe benefits where appropriate) determined pursuant to subparagraphs (a)(2)(ii) or (iii) of this clause shall be paid to all workers performing work in the classification under this contract from the first day on which work is performed in classification.
- (3) Whenever the minimum wage rate prescribed in the contract for a class of laborers or mechanics includes a fringe benefit which is not expressed as an hourly rate, the Contractor shall either pay the benefit as stated in the wage determination or shall pay another bona fide fringe benefit or an hourly cash equivalent thereof.
- (4) If the Contractor does not make payments to a trustee or other third person, the Contractor may consider as part of the wages of any laborer or mechanic the

amount of any costs reasonably anticipated in providing bona fide fringe benefits under a plan or program; provided, that the Secretary of Labor has found, upon the written request of the Contractor, that the applicable standards of the Davis-Bacon Act have been met. The Secretary of Labor may require the Contractor to set aside in a separate account assets for the meeting of obligations under the plan or program.

- (b) Withholding of funds. HUD or its designee shall, upon its own action or upon written request of an authorized representative of the Department of Labor, withhold or cause to be withheld from the Contractor under this contract or any other Federal contract with the same prime Contractor, or any other Federally-assisted contract subject to Davis-Bacon prevailing wage requirements, which is held by the same prime Contractor, so much of the accrued payments or advances as may be considered necessary to pay laborers and mechanics, including apprentices, trainees, and helpers, employed by the Contractor or any subcontractor the full amount of wages required by the contract. In the event of failure to pay any laborer or mechanic, including any apprentice, trainee, or helper, employed or working in the construction or development of the project, all or part of the wages required by the contract, HUD or its designee may, after written notice to the Contractor, take such action as may be necessary to cause the suspension of any further payment, advance, or guarantee of funds until such violations have ceased. HUD or its designee may, after written notice to the Contractor, disburse such amounts withheld for and on account of the Contractor or subcontractor to the respective employees to whom they are due.
- (c) Payrolls and basic records.
- (1) Payrolls and basic records relating thereto shall be maintained by the Contractor during the course of the work and preserved for a period of three years thereafter for all laborers and mechanics working in the construction or development of the project. Such records shall contain the name, address, and social security number of each such worker, his or her correct classification, hourly rates of wages paid (including rates of contributions or costs anticipated for bona fide fringe benefits or cash equivalents thereof of the types described in section 1(b)(2)(B) of the Davis-Bacon Act), daily and weekly number of hours worked, deductions made, and actual wages paid. Whenever the Secretary of Labor has found, under 29 CFR 5.5(a)(1)(iv), that the wages of any laborer or mechanic include the amount of costs reasonably anticipated in providing benefits under a plan or program described in section 1(b)(2)(B) of the Davis-Bacon Act, the Contractor shall maintain records which show that the commitment to provide such benefits is enforceable, that the plan or program is financially responsible, and that the plan or program has been communicated in writing to the laborers or mechanics affected, and records which show the costs anticipated or the actual cost incurred in providing such benefits. Contractors employing apprentices or trainees under approved programs shall maintain written evidence of the registration of apprenticeship programs and certification of trainee programs, the registration of the apprentices and trainees, and the ratios and wage rates prescribed in the applicable programs.

(2) (i) The Contractor shall submit weekly for each week in which any contract work is performed a copy of all payrolls to the Contracting Officer for transmission to HUD or its designee. The payrolls submitted shall set out accurately and completely all of the information required to be maintained under subparagraph (c)(1) of this clause. This information may be submitted in any form desired. Optional Form WH-347 (Federal Stock Number 029-005-00014-1) is available for this purpose and may be purchased from the Superintendent of Documents, U.S. Government Printing Office, Washington, D.C. 20402. The Contractor is responsible for the submission of copies of payrolls by all subcontractors. (Approved by the Office of Management and Budget under OMB Control Number 1214-0149.)

(ii) Each payroll submitted shall be accompanied by a "Statement of Compliance," signed by the Contractor or subcontractor or his or her agent who pays or supervises the payment of the persons employed under the contract and shall certify the following:

- (A) That the payroll for the payroll period contains the information required to be maintained under paragraph (c) (1) of this clause and that such information is correct and complete;
  - (B) That each laborer or mechanic (including each helper, apprentice, and trainee) employed on the contract during the payroll period has been paid the full weekly wages earned, without rebate, either directly or indirectly, and that no deductions have been made either directly or indirectly from the full wages earned, other than permissible deductions as set forth in 29 CFR Part 3; and
  - (C) That each laborer or mechanic has been paid not less than the applicable wage rates and fringe benefits or cash equivalents for the classification of work performed, as specified in the applicable wage determination incorporated into the contract.
- (iii) The weekly submission of a properly executed certification set forth on the reverse side of Optional Form WH-347 shall satisfy the requirements for submission of the "Statement of Compliance" required by subparagraph (c)(2)(ii) of this clause.
- (iv) The falsification of any of the above certifications may subject the Contractor or subcontractor to civil or criminal prosecution under Section 1001 of Title 18 and Section 3729 of Title 31 of the United States Code.

(3) The Contractor or subcontractor shall make the records required under subparagraph (c)(1) available for inspection, copying, or transcription by authorized representatives of HUD or its designee, the Contracting Officer, or the Department of Labor and shall permit such representatives to interview employees during working hours on the job. If the Contractor or subcontractor fails to submit the required records or to make them available, HUD or its designee may, after written notice to the Contractor, take such action as may be necessary to cause the suspension of any further payment, advance, or guarantee of funds. Furthermore, failure to submit the required records upon request or to

make such records available may be grounds for debarment action pursuant to 29 CFR 5.12.

(d) (1) Apprentices. Apprentices will be permitted to work at less than the predetermined rate for the work they performed when they are employed pursuant to and individually registered in a bona fide apprenticeship program registered with the U.S. Department of Labor, Employment and Training Administration, Office of Apprenticeship and Training, Employer and Labor Services (OATELS), or with a State Apprenticeship Agency recognized by OATELS, or if a person is employed in his or her first 90 days of probationary employment as an apprentice in such an apprenticeship program, who is not individually registered in the program, but who has been certified by OATELS or a State Apprenticeship Agency (where appropriate) to be eligible for probationary employment as an apprentice. The allowable ratio of apprentices to journeymen on the job site in any craft classification shall not be greater than the ratio permitted to the Contractor as to the entire work force under the registered program. Any worker listed on a payroll at an apprentice wage rate, who is not registered or otherwise employed as stated in this paragraph, shall be paid not less than the applicable wage rate on the wage determination for the classification of work actually performed. In addition, any apprentice performing work on the job site in excess of the ratio permitted under the registered program shall be paid not less than the applicable wage rate on the wage determination for the work actually performed. Where a contractor is performing construction on a project in a locality other than that in which its program is registered, the ratios and wage rates (expressed in percentages of the journeyman's hourly rate) specified in the Contractor's or subcontractor's registered program shall be observed. Every apprentice must be paid at not less than the rate specified in the registered program for the apprentice's level of progress, expressed as a percentage of the journeyman hourly rate specified in the applicable wage determination. Apprentices shall be paid fringe benefits in accordance with the provisions of the apprenticeship program. If the apprenticeship program does not specify fringe benefits, apprentices must be paid the full amount of fringe benefits listed on the wage determination for the applicable classification. If the Administrator of the Wage and Hour Division determines that a different practice prevails for the applicable apprentice classification, fringes shall be paid in accordance with that determination. In the event OATELS, or a State Apprenticeship Agency recognized by OATELS, withdraws approval of an apprenticeship program, the Contractor will no longer be permitted to utilize apprentices at less than the applicable predetermined rate for the work performed until an acceptable program is approved.

(2) Trainees. Except as provided in 29 CFR 5.16, trainees will not be permitted to work at less than the predetermined rate for the work performed unless they are employed pursuant to and individually registered in a program which has received prior approval, evidenced by formal certification by the U.S. Department of Labor, Employment and Training Administration. The ratio of trainees to journeymen on the job site shall not be greater than permitted under

the plan approved by the Employment and Training Administration. Every trainee must be paid at not less than the rate specified in the approved program for the trainee's level of progress, expressed as a percentage of the journeyman hourly rate specified in the applicable wage determination. Trainees shall be paid fringe benefits in accordance with the provisions of the trainee program. If the trainee program does not mention fringe benefits, trainees shall be paid the full amount of fringe benefits listed in the wage determination unless the Administrator of the Wage and Hour Division determines that there is an apprenticeship program associated with the corresponding journeyman wage rate in the wage determination which provides for less than full fringe benefits for apprentices. Any employee listed on the payroll at a trainee rate who is not registered and participating in a training plan approved by the Employment and Training Administration shall be paid not less than the applicable wage rate in the wage determination for the classification of work actually performed. In addition, any trainee performing work on the job site in excess of the ratio permitted under the registered program shall be paid not less than the applicable wage rate in the wage determination for the work actually performed. In the event the Employment and Training Administration withdraws approval of a training program, the Contractor will no longer be permitted to utilize trainees at less than the applicable predetermined rate for the work performed until an acceptable program is approved.

- (3) Equal employment opportunity. The utilization of apprentices, trainees, and journeymen under this clause shall be in conformity with the equal employment opportunity requirements of Executive Order 11246, as amended, and 29 CFR Part 30.
- (e) Compliance with Copeland Act requirements. The Contractor shall comply with the requirements of 29 CFR Part 3, which are hereby incorporated by reference in this contract.
- (f) Contract termination; debarment. A breach of this contract clause may be grounds for termination of the contract and for debarment as a Contractor and a subcontractor as provided in 29 CFR 5.12.
- (g) Compliance with Davis-Bacon and related Act requirements. All rulings and interpretations of the Davis-Bacon and related Acts contained in 29 CFR Parts 1, 3, and 5 are herein incorporated by reference in this contract.
- (h) Disputes concerning labor standards. Disputes arising out of the labor standards provisions of this clause shall not be subject to the general disputes clause of this contract. Such disputes shall be resolved in accordance with the procedures of the Department of Labor set forth in 29 CFR Parts 5, 6, and 7. Disputes within the meaning of this clause include disputes between the Contractor (or any of its subcontractors) and the PHA, HUD, the U.S. Department of Labor, or the employees or their representatives.
- (i) Certification of eligibility.
  - (1) By entering into this contract, the Contractor certifies that neither it (nor he or she) nor any person or firm who has an interest in the Contractor's firm is a person or firm ineligible to be awarded contracts by the United States Government by virtue of section 3(a) of the Davis-Bacon Act or 29 CFR 5.12(a)(1).

- (2) No part of this contract shall be subcontracted to any person or firm ineligible for award of a United States Government contract by virtue of section 3(a) of the Davis-Bacon Act or 29 CFR 5.12(a)(1).
- (3) The penalty for making false statements is prescribed in the U. S. Criminal Code, 18 U.S.C. 1001.
- (j) Contract Work Hours and Safety Standards Act. As used in this paragraph, the terms "laborers" and "mechanics" include watchmen and guards.
  - (1) Overtime requirements. No contractor or subcontractor contracting for any part of the contract work which may require or involve the employment of laborers or mechanics, including watchmen and guards, shall require or permit any such laborer or mechanic in any workweek in which the individual is employed on such work to work in excess of 40 hours in such workweek unless such laborer or mechanic receives compensation at a rate not less than one and one-half times the basic rate of pay for all hours worked in excess of 40 hours in such workweek.
  - (2) Violation; liability for unpaid wages; liquidated damages. In the event of any violation of the provisions set forth in subparagraph (j)(1) of this clause, the Contractor and any subcontractor responsible therefor shall be liable for the unpaid wages. In addition, such Contractor and subcontractor shall be liable to the United States (in the case of work done under contract for the District of Columbia or a territory, to such District or to such territory), for liquidated damages. Such liquidated damages shall be computed with respect to each individual laborer or mechanic (including watchmen and guards) employed in violation of the provisions set forth in subparagraph (j)(1) of this clause, in the sum of \$27 for each calendar day on which such individual was required or permitted to work in excess of the standard workweek of 40 hours without payment of the overtime wages required by provisions set forth in subparagraph (j)(1) of this clause. DOL posts current fines at: <https://www.dol.gov/whd/govcontracts/cwhssa.htm#cmp>
  - (3) Withholding for unpaid wages and liquidated damages. HUD or its designee shall upon its own action or upon written request of an authorized representative of the Department of Labor withhold or cause to be withheld, from any moneys payable on account of work performed by the Contractor or subcontractor under any such contract or any Federal contract with the same prime Contractor, or any other Federally-assisted contract subject to the Contract Work Hours and Safety Standards Act, which is held by the same prime Contractor, such sums as may be determined to be necessary to satisfy any liabilities of such Contractor or subcontractor for unpaid wages and liquidated damages as provided in the provisions set forth in subparagraph (j)(2) of this clause.
- (k) Subcontracts. The Contractor or subcontractor shall insert in any subcontracts all the provisions contained in this clause, and such other clauses as HUD or its designee may by appropriate instructions require, and also a clause requiring the subcontractors to include these provisions in any lower tier subcontracts. The prime Contractor shall be responsible for the compliance by any subcontractor or lower tier subcontractor with all these provisions.

---

47. Non-Federal Prevailing Wage Rates

(a) Any prevailing wage rate (including basic hourly rate and any fringe benefits), determined under State or tribal law to be prevailing, with respect to any employee in any trade or position employed under the contract, is inapplicable to the contract and shall not be enforced against the Contractor or any subcontractor, with respect to employees engaged under the contract whenever such non-Federal prevailing wage rate exceeds:

(1) The applicable wage rate determined by the Secretary of Labor pursuant to the Davis-Bacon Act (40 U.S.C. 3141 et seq.) to be prevailing in the locality with respect to such trade;

(b) An applicable apprentice wage rate based thereon specified in an apprenticeship program registered with the U.S. Department of Labor (DOL) or a DOL-recognized State Apprenticeship Agency; or

(c) An applicable trainee wage rate based thereon specified in a DOL-certified trainee program.

48. Procurement of Recovered Materials.

(a) In accordance with Section 6002 of the Solid Waste Disposal Act, as amended by the Resource Conservation and Recovery Act, the Contractor shall procure items designated in guidelines of the Environmental Protection Agency (EPA) at 40 CFR Part 247 that contain the highest percentage of recovered materials practicable, consistent with maintaining a satisfactory level of competition. The Contractor shall procure items designated in the EPA guidelines that contain the highest percentage of recovered materials practicable unless the Contractor determines that such items: (1) are not reasonably available in a reasonable period of time; (2) fail to meet reasonable performance standards, which shall be determined on the basis of the guidelines of the National Institute of Standards and Technology, if applicable to the item; or (3) are only available at an unreasonable price.

( ) Paragraph (a) of this clause shall apply to items purchased under this contract where: (1) the Contractor purchases in excess of \$10,000 of the item under this contract; or (2) during the preceding Federal fiscal year, the Contractor: (i) purchased any amount of the items for use under a contract that was funded with Federal appropriations and was with a Federal agency or a State agency or agency of a political subdivision of a State; and (ii) purchased a total of in excess of \$10,000 of the item both under and outside that contract.

# General Conditions for Non-Construction Contracts

## Section I — (With or without Maintenance Work)

## U.S. Department of Housing and Urban Development

Office of Public and Indian Housing

Office of Labor Relations

OMB Approval No. 2577-0157 (exp. 1/31/2027)

Public Reporting Burden for this collection of information is estimated to average one hour per response, including the time for reviewing instructions, searching existing data sources, gathering and maintaining the data needed, and completing and reviewing the collection of information. HUD may not conduct or sponsor, and a person is not required to respond to a collection of information unless it displays a currently valid OMB number. This form includes those clauses required by OMB's common rule on grantee procurement, implemented at HUD in 2 CFR 200, and those requirements set forth in Section 3 of the Housing and Urban Development Act of 1968 and its amendment by the Housing and Community Development Act of 1992, implemented by HUD at 24 CFR Part 75. The form is required for non-construction contracts awarded by Public Housing Agencies (PHAs). The form is used by PHAs in solicitations to provide necessary contract clauses and allows PHAs to enforce their contracts. Comments regarding the accuracy of this burden estimate and any suggestions for reducing this burden can be sent to the Reports Management Officer, Office of Policy Development and Research, REE, Department of Housing and Urban Development, 451 7th St SW, Room 4176, Washington, DC 20410-5000. When providing comments, please refer to OMB Approval No. 2577-0157. Do not send this completed form to either of these addressees. The information collected will not be held confidential.

**Applicability. This form HUD-5370-C has 2 Sections. These Sections must be inserted into non-construction contracts as described below:**

- 1) **Non-construction contracts** (*without* maintenance) **greater than \$250,000 - use Section I;**
- 2) **Maintenance contracts** (including nonroutine maintenance as defined at 24 CFR 905.100) **greater than \$2,000 but not more than \$250,000 - use Section II;** and
- 3) **Maintenance contracts** (including nonroutine maintenance), **greater than \$250,000 — use Sections I and II.**

### Section I - Clauses for All Non-Construction Contracts greater than \$250,000

#### 1. Definitions

The following definitions are applicable to this contract:

- (a) "Authority or Housing Authority (HA)" means the Housing Authority.
- (b) "Contract" means the contract entered into between the Authority and the Contractor. It includes the contract form, the Certifications and Representations, these contract clauses, and the scope of work. It includes all formal changes to any of those documents by addendum, Change Order, or other modification.
- (c) "Contractor" means the person or other entity entering into the contract with the Authority to perform all of the work required under the contract.
- (d) "Day" means calendar days, unless otherwise stated.
- (e) "HUD" means the Secretary of Housing and Urban Development, his delegates, successors, and assigns, and the officers and employees of the United States Department of Housing and Urban Development acting for and on behalf of the Secretary.

#### 2. Changes

- (a) The HA may at any time, by written order, and without notice to the sureties, if any, make changes within the general scope of this contract in the services to be performed or supplies to be delivered.
- (b) If any such change causes an increase or decrease in the hourly rate, the not-to-exceed amount of the contract, or the time required for performance of any part of the work under this contract, whether or not changed by the order, or otherwise affects the conditions of this contract, the HA shall make an equitable adjustment in the not-to-exceed amount, the hourly rate, the delivery schedule, or other affected terms, and shall modify the contract accordingly.
- (c) The Contractor must assert its right to an equitable adjustment under this clause within 30 days from the date of receipt of the written order. However, if the HA decides that the facts justify it, the HA may receive and act upon a

- (d) proposal submitted before final payment of the contract.
- (d) Failure to agree to any adjustment shall be a dispute under clause Disputes, herein. However, nothing in this clause shall excuse the Contractor from proceeding with the contract as changed.
- (e) No services for which an additional cost or fee will be charged by the Contractor shall be furnished without the prior written consent of the HA.

#### 3. Termination for Convenience and Default

- (a) The HA may terminate this contract in whole, or from time to time in part, for the HA's convenience or the failure of the Contractor to fulfill the contract obligations (default). The HA shall terminate by delivering to the Contractor a written Notice of Termination specifying the nature, extent, and effective date of the termination. Upon receipt of the notice, the Contractor shall: (i) immediately discontinue all services affected (unless the notice directs otherwise); and (ii) deliver to the HA all information, reports, papers, and other materials accumulated or generated in performing this contract, whether completed or in process.
- (b) If the termination is for the convenience of the HA, the HA shall be liable only for payment for services rendered before the effective date of the termination.
- (c) If the termination is due to the failure of the Contractor to fulfill its obligations under the contract (default), the HA may (i) require the Contractor to deliver to it, in the manner and to the extent directed by the HA, any work as described in subparagraph (a)(ii) above, and compensation be determined in accordance with the Changes clause, paragraph 2, above; (ii) take over the work and prosecute the same to completion by contract or otherwise, and the Contractor shall be liable for any additional cost incurred by the HA; (iii) withhold any payments to the Contractor, for the purpose of off-set or partial payment, as the case may be, of amounts owed to the HA by the Contractor.
- (d) If, after termination for failure to fulfill contract obligations (default), it is determined that the Contractor had not failed, the termination shall be deemed to have been effected for the convenience of the HA, and the Contractor shall be entitled to payment as described in paragraph (b) above.
- (e) Any disputes with regard to this clause are expressly made subject to the terms of clause titled Disputes herein.

#### 4. Examination and Retention of Contractor's Records

- (a) The HA, HUD, or Comptroller General of the United States, or any of their duly authorized representatives shall, until 3 years after final payment under this contract, have access to and the right to examine any of the Contractor's directly pertinent books, documents, papers, or other records involving transactions related to this contract for the purpose of making audit, examination, excerpts, and transcriptions.

- 
- (b) The Contractor agrees to include in first-tier subcontracts under this contract a clause substantially the same as paragraph (a) above. "Subcontract," as used in this clause, excludes purchase orders not exceeding \$10,000.
  - (c) The periods of access and examination in paragraphs (a) and (b) above for records relating to:
    - (i) appeals under the clause titled Disputes;
    - (ii) litigation or settlement of claims arising from the performance of this contract; or,
    - (iii) costs and expenses of this contract to which the HA, HUD, or Comptroller General or any of their duly authorized representatives has taken exception shall continue until disposition of such appeals, litigation, claims, or exceptions.

#### 5. Rights in Data (Ownership and Proprietary Interest)

The HA shall have exclusive ownership of, all proprietary interest in, and the right to full and exclusive possession of all information, materials and documents discovered or produced by Contractor pursuant to the terms of this Contract, including but not limited to reports, memoranda or letters concerning the research and reporting tasks of this Contract.

#### 6. Energy Efficiency

The contractor shall comply with all mandatory standards and policies relating to energy efficiency which are contained in the energy conservation plan issued in compliance with the Energy Policy and Conservation Act (Pub.L. 94-163) for the State in which the work under this contract is performed.

#### 7. Disputes

- (a) All disputes arising under or relating to this contract, except for disputes arising under clauses contained in Section 111, Labor Standards Provisions, including any claims for damages for the alleged breach there of which are not disposed of by agreement, shall be resolved under this clause.
- (b) All claims by the Contractor shall be made in writing and submitted to the HA. A claim by the HA against the Contractor shall be subject to a written decision by the HA.
- (c) The HA shall, with reasonable promptness, but in no event in no more than 60 days, render a decision concerning any claim hereunder. Unless the Contractor, within 30 days after receipt of the HA's decision, shall notify the HA in writing that it takes exception to such decision, the decision shall be final and conclusive.
- (d) Provided the Contractor has (i) given the notice within the time stated in paragraph (c) above, and (ii) excepted its claim relating to such decision from the final release, and (iii) brought suit against the HA not later than one year after receipt of final payment, or if final payment has not been made, not later than one year after the Contractor has had a reasonable time to respond to a written request by the HA that it submit a final voucher and release, whichever is earlier, then the HA's decision shall not be final or conclusive, but the dispute shall be determined on the merits by a court of competent jurisdiction.
- (e) The Contractor shall proceed diligently with performance of this contract, pending final resolution of any request for relief, claim, appeal, or action arising under the contract, and comply with any decision of the HA.

#### 8. Contract Termination; Debarment

A breach of these Contract clauses may be grounds for termination of the Contract and for debarment or denial of participation in HUD programs as a Contractor and a subcontractor as provided in 24 CFR Part 24.

#### 9. Assignment of Contract

The Contractor shall not assign or transfer any interest in this contract; except that claims for monies due or to become due from the HA under the contract may be assigned to a bank, trust company, or other financial institution. If the Contractor is a partnership, this contract shall inure to the benefit of the surviving or remaining member(s) of such partnership approved by the HA.

#### 10. Certificate and Release

Prior to final payment under this contract, or prior to settlement upon termination of this contract, and as a condition precedent thereto, the Contractor shall execute and deliver to the HA a certificate and release, in a form acceptable to the HA, of all claims against the HA by the Contractor under and by virtue of this contract, other than such claims, if any, as may be specifically excepted by the Contractor in stated amounts set forth therein.

#### 11. Organizational Conflicts of Interest

- (a) The Contractor warrants that to the best of its knowledge and belief and except as otherwise disclosed, it does not have any organizational conflict of interest which is defined as a situation in which the nature of work under this contract and a contractor's organizational, financial, contractual or other interests are such that:
  - (i) Award of the contract may result in an unfair competitive advantage; or
  - ( ) The Contractor's objectivity in performing the contract work may be impaired.
- (b) The Contractor agrees that if after award it discovers an organizational conflict of interest with respect to this contract or any task/delivery order under the contract, he or she shall make an immediate and full disclosure in writing to the Contracting Officer which shall include a description of the action which the Contractor has taken or intends to take to eliminate or neutralize the conflict. The HA may, however, terminate the contract or task/delivery order for the convenience of the HA if it would be in the best interest of the HA.
- (c) In the event the Contractor was aware of an organizational conflict of interest before the award of this contract and intentionally did not disclose the conflict to the Contracting Officer, the HA may terminate the contract for default.
- (d) The terms of this clause shall be included in all subcontracts and consulting agreements wherein the work to be performed is similar to the service provided by the prime Contractor. The Contractor shall include in such subcontracts and consulting agreements any necessary provisions to eliminate or neutralize conflicts of interest.

#### 12. Inspection and Acceptance

- (a) The HA has the right to review, require correction, if necessary, and accept the work products produced by the Contractor. Such review(s) shall be carried out within 30 days so as to not impede the work of the Contractor. Any

---

product of work shall be deemed accepted as submitted if the HA does not issue written comments and/or required corrections within 30 days from the date of receipt of such product from the Contractor.

- (b) The Contractor shall make any required corrections promptly at no additional charge and return a revised copy of the product to the HA within 7 days of notification or a later date if extended by the HA.
- (c) Failure by the Contractor to proceed with reasonable promptness to make necessary corrections shall be a default. If the Contractor's submission of corrected work remains unacceptable, the HA may terminate this contract (or the task order involved) or reduce the contract price or cost to reflect the reduced value of services received.

### 13. Interest of Members of Congress

No member of or delegate to the Congress of the United States of America or Resident Commissioner shall be admitted to any share or part of this contract or to any benefit to arise there from, but this provision shall not be construed to extend to this contract if made with a corporation for its general benefit.

### 14. Interest of Members, Officers, or Employees and Former Members, Officers, or Employees

No member, officer, or employee of the HA, no member of the governing body of the locality in which the project is situated, no member of the governing body in which the HA was activated, and no other public official of such locality or localities who exercises any functions or responsibilities with respect to the project, shall, during his or her tenure, or for one year thereafter, have any interest, direct or indirect, in this contract or the proceeds thereof.

### 15. Limitation on Payments to Influence Certain Federal Transactions

(a) Definitions. As used in this clause:

"Agency", as defined in 5 U.S.C. 552(f), includes Federal executive departments and agencies as well as independent regulatory commissions and Government corporations, as defined in 31 U.S.C. 9101(1).

"Covered Federal Action" means any of the following Federal actions:

- (i) The awarding of any Federal contract;
- (ii) The making of any Federal grant;
- (iii) The making of any Federal loan;
- (iv) The entering into of any cooperative agreement; and,
- (v) The extension, continuation, renewal, amendment, or modification of any Federal contract, grant, loan, or cooperative agreement.

Covered Federal action does not include receiving from an agency a commitment providing for the United States to insure or guarantee a loan.

"Indian tribe" and "tribal organization" have the meaning provided in section 4 of the Indian Self-Determination and Education Assistance Act (25 U.S.C. 450B). Alaskan Natives are included under the definitions of Indian tribes in that Act.

"Influencing or attempting to influence" means making, with the intent to influence, any communication to or appearance before an officer or employee of any agency, a Member of Congress, an officer or employee of Congress, or an employee of a Member of Congress in connection with any covered Federal action.

"Local government" means a unit of government in a State and, if chartered, established, or otherwise recognized by a State for the performance of a governmental duty, including a local public authority, a special district, an intrastate district, a council of governments, a sponsor group representative organization, and any other instrumentality of a local government

"Officer or employee of an agency" includes the following individuals who are employed by an agency:

- (i) An individual who is appointed to a position in the Government under title 5, U.S.C., including a position under a temporary appointment;
- (ii) A member of the uniformed services as defined in section 202, title 18, U.S.C.;
- (iii) A special Government employee as defined in section 202, title 18, U.S.C.; and,
- (iv) An individual who is a member of a Federal advisory committee, as defined by the Federal Advisory Committee Act, title 5, appendix 2.

"Person" means an individual, corporation, company, association, authority, firm, partnership, society, State, and local government, regardless of whether such entity is operated for profit or not for profit. This term excludes an Indian tribe, tribal organization, or other Indian organization with respect to expenditures specifically permitted by other Federal law.

"Recipient" includes all contractors, subcontractors at any tier, and subgrantees at any tier of the recipient of funds received in connection with a Federal contract, grant, loan, or cooperative agreement. The term excludes an Indian tribe, tribal organization, or any other Indian organization with respect to expenditures specifically permitted by other Federal law.

"Regularly employed means, with respect to an officer or employee of a person requesting or receiving a Federal contract, grant, loan, or cooperative agreement, an officer or employee who is employed by such person for at least 130 working days within one year immediately preceding the date of the submission that initiates agency consideration of such person for receipt of such contract, grant, loan, or cooperative agreement. An officer or employee who is employed by such person for less than 130 working days within one year immediately preceding the date of submission that initiates agency consideration of such person shall be considered to be regularly employed as soon as he or she is employed by such person for 130 working days.

"State" means a State of the United States, the District of Columbia, the Commonwealth of Puerto Rico, a territory or possession of the United States, an agency or instrumentality of a State, and a multi-State, regional, or interstate entity having governmental duties and powers.

(b) Prohibition.

- (i) Section 1352 of title 31, U.S.C. provides in part that no appropriated funds may be expended by the recipient of a Federal contract, grant, loan, or cooperative agreement to pay any person for influencing or attempting to influence an officer or employee of any agency, a Member of Congress, an officer or employee of Congress, or an employee of a Member of Congress in connection with any of the following covered Federal actions: the awarding of any Federal contract, the making of any Federal grant, the making of any Federal loan, the entering into of any cooperative agreement, and the extension, continuation, renewal, amendment, or modification of any Federal contract, grant, loan, or cooperative agreement.

(v) The prohibition does not apply as follows:

(1) Agency and legislative liaison by Own Employees.

(a) The prohibition on the use of appropriated funds, in paragraph (i) of this section, does not apply in the case of a payment of reasonable compensation made to an officer or employee of a person requesting or receiving a Federal contract, grant, loan, or cooperative agreement, if the payment is for agency and legislative activities not directly related to a covered Federal action.

(b) For purposes of paragraph (b)(i)(1)(a) of this clause, providing any information specifically requested by an agency or Congress is permitted at any time.

(c) The following agency and legislative liaison activities are permitted at any time only where they are not related to a specific solicitation for any covered Federal action:

(1) Discussing with an agency (including individual demonstrations) the qualities and characteristics of the person's products or services, conditions or terms of sale, and service capabilities; and,

(2) Technical discussions and other activities regarding the application or adaptation of the person's products or services for an agency's use.

(d) The following agency and legislative liaison activities are permitted where they are prior to formal solicitation of any covered Federal action:

(1) Providing any information not specifically requested but necessary for an agency to make an informed decision about initiation of a covered Federal action;

(2) Technical discussions regarding the preparation of an unsolicited proposal prior to its official submission; and

(3) Capability presentations by persons seeking awards from an agency pursuant to the provisions of the Small Business Act, as amended by Public Law 95-507 and other subsequent amendments.

(e) Only those activities expressly authorized by subdivision (b)(ii)(1)(a) of this clause are permitted under this clause.

(2) Professional and technical services.

(a) The prohibition on the use of appropriated funds, in subparagraph (b)(i) of this clause, does not apply in the case of-

(i) A payment of reasonable compensation made to an officer or employee of a person requesting or receiving a covered Federal action or an extension, continuation, renewal, amendment, or modification of a covered Federal action, if payment is for professional or technical services rendered directly in the preparation, submission, or negotiation of any bid, proposal, or application for that Federal action or for meeting requirements imposed by or pursuant to law as a condition for receiving that Federal action.

(i) Any reasonable payment to a person, other than an officer or employee of a

person requesting or receiving a covered Federal action or an extension, continuation, renewal, amendment, or modification of a covered Federal action if the payment is for professional or technical services rendered directly in the preparation, submission, or negotiation of any bid, proposal, or application for that Federal action or for meeting requirements imposed by or pursuant to law as a condition for receiving that Federal action. Persons other than officers or employees of a person requesting or receiving a covered Federal action include consultants and trade associations.

(b) For purposes of subdivision (b)(ii)(2)(a) of clause, "professional and technical services" shall be limited to advice and analysis directly applying any professional or technical discipline.

(c) Requirements imposed by or pursuant to law as a condition for receiving a covered Federal award include those required by law or regulation, or reasonably expected to be required by law or regulation, and any other requirements in the actual award documents.

(d) Only those services expressly authorized by subdivisions (b)(ii)(2)(a)(i) and (ii) of this section are permitted under this clause.

(iii) Selling activities by independent sales representatives.

(c) The prohibition on the use of appropriated funds, in subparagraph (b)(i) of this clause, does not apply to the following selling activities before an agency by independent sales representatives, provided such activities are prior to formal solicitation by an agency and are specifically limited to the merits of the matter:

(i) Discussing with an agency (including individual demonstration) the qualities and characteristics of the person's products or services, conditions or terms of sale, and service capabilities; and

(ii) Technical discussions and other activities regarding the application or adaptation of the person's products or services for an agency's use.

(d) Agreement. In accepting any contract, grant, cooperative agreement, or loan resulting from this solicitation, the person submitting the offer agrees not to make any payment prohibited by this clause.

(e) Penalties. Any person who makes an expenditure prohibited under paragraph (b) of this clause shall be subject to civil penalties as provided for by 31 U.S.C. 1352. An imposition of a civil penalty does not prevent the Government from seeking any other remedy that may be applicable.

(f) Cost Allowability. Nothing in this clause is to be interpreted to make allowable or reasonable any costs which would be unallowable or unreasonable in accordance with Part 31 of the Federal Acquisition Regulation (FAR), or OMB Circulars dealing with cost allowability for recipients of assistance agreements. Conversely, costs made specifically unallowable by the requirements in this clause will not be made allowable under any of the provisions of FAR Part 31 or the relevant OMB Circulars.

## 16. Equal Employment Opportunity

During the performance of this contract, the

Contractor/Seller agrees as follows:

(a) The [contractor/seller] will not discriminate against any employee or applicant for employment because of race, color, religion, sex, sexual orientation, gender identity, disability, or national origin. The

[contractor/seller] will take affirmative action to ensure that applicants are employed, and that employees are treated during employment, without regard to their race, color, religion, sex, sexual orientation, gender identity, disability, or national origin. Such action shall include, but not be limited to the following: Employment, upgrading, demotion, or transfer, recruitment or recruitment advertising; layoff or termination; rates of pay or other forms of compensation; and selection for training, including apprenticeship. The [contractor/seller] agrees to post in conspicuous places, available to employees and applicants for employment, notices to be provided by the contracting officer setting forth the provisions of this nondiscrimination clause.

(b) The [contractor/seller] will, in all solicitations or advertisements for employees placed by or on behalf of the [contractor/seller], state that all qualified applicants will receive consideration for employment without regard to race, color, religion, sex, sexual orientation, gender identity, disability, or national origin.

(c) The [contractor/seller] will not discharge or in any other manner discriminate against any employee or applicant for employment because such employee or applicant has inquired about, discussed, or disclosed the compensation of the employee or applicant or another employee or applicant. This provision shall not apply to instances in which an employee who has access to the compensation information of other employees or applicants as a part of such employee's essential job functions discloses the compensation of such other employees or applicants to individuals who do not otherwise have access to such information, unless such disclosure is in response to a formal complaint or charge, in furtherance of an investigation, proceeding, hearing, or action, including an investigation conducted by the employer, or is consistent with the [contractor/seller]'s legal duty to furnish information.

(d) The [contractor/seller] will send to each labor union or representative of workers with which it has a collective bargaining agreement or other contract or understanding, a notice to be provided by the agency contracting officer, advising the labor union or workers' representative of the [contractor/seller]'s commitments under section 202 of Executive Order 11246 of September 24, 1965, and shall post copies of the notice in conspicuous places available to employees and applicants for employment.

(e) The [contractor/seller] will comply with all provisions of Executive Order 11246 of September 24, 1965, and of the rules, regulations, and relevant orders of the Secretary of Labor.

(f) The [contractor/seller] will furnish all information and reports required by Executive Order 11246 of September 24, 1965, and by the rules, regulations, and orders of the Secretary of Labor, or pursuant thereto, and will permit access to his books, records, and accounts by the contracting agency and the Secretary of Labor for purposes of investigation to ascertain compliance with such rules, regulations, and orders.

(g) In the event of the [contractor/seller]'s non-compliance with the nondiscrimination clauses of this contract or with any of such rules, regulations, or orders, this contract may be canceled, terminated or suspended in whole or in part and the [contractor/seller] may be declared ineligible for further Government contracts in accordance with procedures authorized in Executive Order 11246 of September 24, 1965, and such other sanctions may be imposed and remedies invoked as provided in Executive Order 11246 of September 24, 1965, or by rule, regulation, or order of the Secretary of Labor, or as otherwise provided by law.

(g) In the event of the [contractor/seller]'s non-compliance with the nondiscrimination clauses of this contract or with any of such rules, regulations, or orders, this contract may be canceled, terminated or suspended in whole or in part and the [contractor/seller] may be declared ineligible for further Government contracts in accordance with procedures authorized in Executive Order 11246 of September 24, 1965, and such other sanctions may be imposed and remedies invoked as provided in Executive Order 11246 of September 24, 1965, or by rule, regulation, or order of the Secretary of Labor, or as otherwise provided by law.

(h) The [contractor/seller] will include the provisions of paragraphs (a) through (h) in every subcontract or purchase order unless exempted by rules, regulations, or orders of the Secretary of Labor issued pursuant to section 204 of Executive Order 11246 of September 24, 1965, so that such provisions will be binding upon each sub[contractor/seller] or vendor. The [contractor/seller] will take such action with respect to any subcontract or purchase order as may be directed by the Secretary of Labor as a means of enforcing such provisions including sanctions for noncompliance: Provided, however, that in the event the [contractor/seller] becomes involved in, or is threatened with, litigation with a subcontractor or vendor as a result of such direction, the [contractor/seller] may request the United States to enter into such litigation to protect the interests of the United States.

## 17. Equal Opportunity for Workers with Disabilities

1. The [contractor/seller] will not discriminate against any employee or applicant for employment because of physical or mental disability in regard to any position for which the employee or applicant for employment is qualified. The [contractor/seller] agrees to take affirmative action to employ and advance in employment individuals with disabilities, and to treat qualified individuals without discrimination on the basis of their physical or mental disability in all employment practices, including the following:

- i. Recruitment, advertising, and job application procedures;
- ii. Hiring, upgrading, promotion, award of tenure, demotion, transfer, layoff, termination, right of return from layoff and rehiring;
- iii. Rates of pay or any other form of compensation and changes in compensation;
- iv. Job assignments, job classifications, organizational structures, position descriptions, lines of progression, and seniority lists;
- v. Leaves of absence, sick leave, or any other leave;
- vi. Fringe benefits available by virtue of employment, whether or not administered by the [contractor/seller];
- vii. Selection and financial support for training, including apprenticeship, professional meetings, conferences, and other related activities, and selection for leaves of absence to pursue training;
- viii. Activities sponsored by the [contractor/seller] including social or recreational programs; and
- ix. Any other term, condition, or privilege of employment.

2. The [contractor/seller] agrees to comply with the rules, regulations, and relevant orders of the Secretary of Labor issued pursuant to the act.

3. In the event of the [contractor/seller] noncompliance with the requirements of this clause, actions for noncompliance may be taken in accordance with the rules, regulations, and relevant orders of the Secretary of Labor issued pursuant to the act.

4. The [contractor/seller] agrees to post in conspicuous places, available to employees and applicants for employment, notices in a form to be prescribed by the Director, Office of Federal Contract Compliance Programs, provided by or through the contracting officer. Such notices shall state the rights of applicants and employees as well as the [contractor/seller]'s obligation under the law to take affirmative action to employ and advance in employment qualified employees and applicants with disabilities.

The [contractor/seller] must ensure that applicants or employees with disabilities are provided the notice in a form that is accessible and understandable to the individual applicant or employee (e.g., providing Brail or large print versions of the notice, or posting a copy of the notice at a lower height for easy viewing by a person using a wheelchair). With respect to employees who do not work at a physical location of the [contractor/seller], a [contractor/seller] will satisfy its posting obligations by posting such notices in an electronic format, provided that the [contractor/seller] provides computers, or access to computers, that can access the electronic posting to such employees, or the [contractor/seller] has actual knowledge that such employees otherwise are able to access the electronically posted notices. Electronic notices for employees must be posted in a conspicuous location and format on the company's intranet or sent by electronic mail to employees. An electronic posting must be used by the [contractor/seller] to notify job applicants of their rights if the [contractor/seller] utilizes an electronic application process. Such electronic applicant notice must be conspicuously stored with, or as part of, the electronic application.

5. The [contractor/seller] will notify each labor organization or representative of workers with which it has a collective bargaining agreement or other contract understanding, that the [contractor/seller] is bound by the terms of section 503 of the Rehabilitation Act of 1973, as amended, and is committed to take affirmative action to employ and advance in employment, and shall not discriminate against, individuals with physical or mental disabilities.

6. The [contractor/seller] will include the provisions of this clause in every subcontract or purchase order in excess of \$ 10,000, unless exempted by the rules, regulations, or orders of the Secretary issued pursuant to section 503 of the act, as amended, so that such provisions will be binding upon each subcontractor or vendor. The contractor will take such action with respect to any subcontract or purchase order as the Director, Office of Federal Contract Compliance Programs may direct to enforce such provisions, including action for noncompliance.

7. The [contractor/seller] must, in all solicitations or advertisements for employees placed by or on behalf of the [contractor/seller], state that all qualified applicants will receive consideration for employment and will not be discriminated against on the basis of disability.

#### **18. Dissemination or Disclosure of Information**

No information or material shall be disseminated or disclosed to the general public, the news media, or any person or organization without prior express written approval by the HA.

#### **19. Contractor's Status**

It is understood that the Contractor is an independent contractor and is not to be considered an employee of the HA, or assume any right, privilege or duties of an employee, and shall save harmless the HA and its employees from claims suits, actions and costs of every description resulting from the Contractor's activities on behalf of the HA in connection with this Agreement.

#### **20. Other Contractors**

HA may undertake or award other contracts for additional work at or near the site(s) of the work under this contract. The contractor shall fully cooperate with the other contractors and with HA and HUD employees and shall carefully adapt scheduling and performing the work under this contract to accommodate the additional work, heeding any direction that may be provided by the Contracting Officer. The contractor shall not commit or permit any act that will interfere with the performance of work by any other contractor or HA employee.

#### **21. Liens**

The Contractor is prohibited from placing a lien on HA's property. This prohibition shall apply to all subcontractors.

#### **22. Training and Employment Opportunities for Residents in the Project Area** (Section 3, HUD Act of 1968; 24 CFR 135)

- (a) The work to be performed under this contract is subject to the requirements of section 3 of the Housing and Urban Development Act of 1968, as amended, 12 U.S.C. 1701u (section 3). The purpose of section 3 is to ensure that employment and other economic opportunities generated by HUD assistance or HUD-assisted projects covered by section 3, shall, to the greatest extent feasible, be directed to low- and very low-income persons, particularly persons who are recipients of HUD assistance for housing.
- (b) The parties to this contract agree to comply with HUD's regulations in 24 CFR Part 75, which implement section 3. As evidenced by their execution of this contract, the parties to this contract certify that they are under no contractual or other impediment that would prevent them from complying with the Part 75 regulations.
- (c) The contractor agrees to send to each labor organization or representative of workers with which the contractor has a collective bargaining agreement or other understanding, if any, a notice advising the labor organization or workers' representative of the contractor's commitments under this section 3 clause, and will post copies of the notice in conspicuous places at the work site where both employees and applicants for training and employment positions can see the notice. The notice shall describe the section 3 prioritization requirements, and shall state the minimum percentages of labor hour requirements established in the Benchmark Notice (FR-6085-N-04).
- (d) The contractor agrees to include this section 3 clause in every subcontract subject to compliance with regulations in 24 CFR Part 75, and agrees to take appropriate action, as provided in an applicable provision of the subcontract or in this section 3 clause, upon a finding that the subcontractor is in violation of the regulations in 24 CFR Part 75. The contractor will not subcontract with any subcontractor where the contractor has notice or knowledge that the subcontractor has been found in violation of the regulations in 24 CFR Part 75.
- (e) Noncompliance with HUD's regulations in 24 CFR Part 75 may result in sanctions, termination of this contract for default, and debarment or suspension from future HUD assisted contracts
- (f) Contracts, subcontracts, grants, or subgrants subject to Section 7(b) of the Indian Self-Determination and Education Assistance Act (25 U.S.C. 5307(b)) or subject to tribal preference requirements as authorized under 101(k) of the Native American Housing Assistance and Self-Determination Act (25 U.S.C. 4111(k)) must provide preferences in employment, training, and business opportunities to Indians and Indian organizations, and are therefore not subject to the requirements of 24 CFR Part 75.

#### **23. Procurement of Recovered Materials**

- (a) In accordance with Section 6002 of the Solid Waste Disposal Act, as amended by the Resource Conservation and Recovery Act, the Contractor shall procure items designated in guidelines of the Environmental Protection Agency (EPA) at 40 CFR Part 247 that contain the highest percentage of recovered

materials practicable consistent with maintaining a satisfactory level of competition. The Contractor shall procure items designated in the EPA guidelines that contain the highest percentage of recovered materials practicable unless the Contractor determines that such items: (1) are not reasonably available in a reasonable period of time; (2) fail to meet reasonable performance standards, which shall be determined on the basis of the guidelines of the National Institute of Standards and Technology, if applicable to the item; or (3) are only available at an unreasonable price.

- (b) Paragraph (a) of this clause shall apply to items purchased under this contract where: (1) the Contractor purchases in excess of \$10,000 of the item under this contract; or (2) during the preceding Federal fiscal year, the Contractor: (i) purchased any amount of the items for use under a contract that was funded with Federal appropriations and was with a Federal agency or a State agency or agency of a political subdivision of a State; and (ii) purchased a total of in excess of \$10,000 of the item both under and outside that contract

# General Conditions for Non-Construction Contracts

## Section II – (With Maintenance Work)

### U.S. Department of Housing and Urban Development

Office of Public and Indian Housing

Office of Labor Relations

OMB Approval No. 2577-0157 (exp. 1/31/2027)

Public Reporting Burden for this collection of information is estimated to average one hour per response, including the time for reviewing instructions, searching existing data sources, gathering and maintaining the data needed, and completing and reviewing the collection of information. HUD may not conduct or sponsor, and a person is not required to respond to a collection of information unless it displays a currently valid OMB number. This form includes those clauses required by OMB's common rule on grantee procurement, implemented at HUD in 2 CFR 200, and those requirements set forth in Section 3 of the Housing and Urban Development Act of 1968 and its amendment by the Housing and Community Development Act of 1992, implemented by HUD at 24 CFR Part 75. The form is required for maintenance contracts awarded by Public Housing Agencies (PHAs). The form is used by PHAs in solicitations to provide necessary contract clauses and allows PHAs to enforce their contracts. Comments regarding the accuracy of this burden estimate and any suggestions for reducing this burden can be sent to the Reports Management Officer, Office of Policy Development and Research, REE, Department of Housing and Urban Development, 451 7th St SW, Room 4176, Washington, DC 20410-5000. When providing comments, please refer to OMB Approval No. 2577-0157. Do not send this completed form to either of these addressees. The information collected will not be held confidential.

**Applicability. This form HUD-5370C has 2 Sections. These Sections must be inserted into non-construction contracts as described below:**

in the classification under this Contract from the first day on which work is performed in the classification.

- 1) Non-construction contracts (*without* maintenance) greater than \$250,000 - use Section I;
- 2) Maintenance contracts (including nonroutine maintenance as defined at 24 CFR 905.200) greater than \$2,000 but not more than \$250,000 - use Section II; and
- 3) Maintenance contracts (including nonroutine maintenance), greater than \$250,000 – use Sections I and II.

### 2. Withholding of funds

The Contracting Officer, upon his/her own action or upon request of HUD, shall withhold or cause to be withheld from the Contractor under this Contract or any other contract subject to HUD-determined wage rates, with the same prime Contractor, so much of the accrued payments or advances as may be considered necessary to pay laborers and mechanics employed by the Contractor or any subcontractor the full amount of wages required by this clause. In the event of failure to pay any laborer or mechanic employed under this Contract all or part of the wages required under this Contract, the Contracting Officer or HUD may, after written notice to the Contractor, take such action as may be necessary to cause the suspension of any further payment or advance until such violations have ceased. The Public Housing Agency or HUD may, after written notice to the Contractor, disburse such amounts withheld for and on account of the Contractor or subcontractor to the respective employees to whom they are due.

### Section II – Labor Standard Provisions for all Maintenance Contracts greater than \$2,000

#### 1. Minimum Wages

- (a) All maintenance laborers and mechanics employed under this Contract in the operation of the project(s) shall be paid unconditionally and not less often than semi-monthly, and without subsequent deduction (except as otherwise provided by law or regulations), the full amount of wages due at time of payment computed at rates not less than those contained in the wage determination of the Secretary of Housing and Urban Development which is attached hereto and made a part hereof. Such laborers and mechanics shall be paid the appropriate wage rate on the wage determination for the classification of work actually performed, without regard to skill. Laborers or mechanics performing work in more than one classification may be compensated at the rate specified for each classification for the time actually worked therein; provided, that the employer's payroll records accurately set forth the time spent in each classification in which work is performed. The wage determination, including any additional classifications and wage rates approved by HUD under subparagraph 1(b), shall be posted at all times by the Contractor and its subcontractors at the site of the work in a prominent and accessible place where it can be easily seen by the workers.
- (b) (i) Any class of laborers or mechanics which is not listed in the wage determination and which is to be employed under the Contract shall be classified in conformance with the wage determination. HUD shall approve an additional classification and wage rate only when the following criteria have been met:
  - (1) The work to be performed by the classification required is not performed by a classification in the wage determination;
  - (2) The classification is utilized in the area by the industry; and
  - (3) The proposed wage rate bears a reasonable relationship to the wage rates contained in the wage determination.
- (ii) The wage rate determined pursuant to this paragraph shall be paid to all workers performing work

#### 3. Records

- (a) The Contractor and each subcontractor shall make and maintain for three (3) years from the completion of the work records containing the following for each laborer and mechanic:
  - (i) Name, address and Social Security Number;
  - (ii) Correct work classification or classifications;
  - (iii) Hourly rate or rates of monetary wages paid;
  - (iv) Rate or rates of any fringe benefits provided;
  - (v) Number of daily and weekly hours worked;
  - (vi) Gross wages earned;
  - (vii) Any deductions made; and
  - (viii) Actual wages paid.
- (b) The Contractor and each subcontractor shall make the records required under paragraph 3(a) available for inspection, copying, or transcription by authorized representatives of HUD or the HA and shall permit such representatives to interview employees during working hours on the job. If the Contractor or any subcontractor fails to make the required records available, HUD or its designee may, after written notice to the Contractor, take such action as may be necessary to cause the suspension of any further payment, advance or guarantee of funds.

#### 4. Apprentices and Trainees

- (a) Apprentices and trainees will be permitted to work at less than the predetermined rate for the work they perform when they are employed pursuant to and individually registered in:
  - (i) A bona fide apprenticeship program registered with the U.S. Department of Labor, Employment and Training Administration (ETA), Office of

- Apprenticeship Training, Employer and Labor Services (OATELS), or with a state apprenticeship agency recognized by OATELS, or if a person is employed in his/her first 90 days of probationary employment as an apprentice in such an apprenticeship program, who is not individually registered in the program, but who has been certified by OATELS or a state apprenticeship agency (where appropriate) to be eligible for probationary employment as an apprentice; A
- (ii) trainee program which has received prior approval, evidenced by formal certification by the U.S. Department of Labor, ETA; or
  - (iii) A training/trainee program that has received prior approval by HUD.
- (b) Each apprentice or trainee must be paid at not less than the rate specified in the registered or approved program for the apprentice's/trainee's level of progress, expressed as a percentage of the journeyman hourly rate specified in the applicable wage determination. Apprentices and trainees shall be paid fringe benefits in accordance with the provisions of the registered or approved program. If the program does not specify fringe benefits, apprentices/trainees must be paid the full amount of fringe benefits listed on the wage determination for the applicable classification.
- (c) The allowable ratio of apprentices or trainees to journeyman on the job site in any craft classification shall not be greater than the ratio permitted to the employer as to the entire work force under the approved program.
- (d) Any worker employed at an apprentice or trainee wage rate who is not registered in an approved program, and any apprentice or trainee performing work on the job site in excess of the ratio permitted under the approved program, shall be paid not less than the applicable wage rate on the wage determination for the classification of work actually performed.
- (e) In the event OATELS, a state apprenticeship agency recognized by OATELS or ETA, or HUD, withdraws approval of an apprenticeship or trainee program, the employer will no longer be permitted to utilize apprentices/trainees at less than the applicable predetermined rate for the work performed until an acceptable program is approved.

## 5. Disputes concerning labor standards

- (a) Disputes arising out of the labor standards provisions contained in Section II of this form HUD-5370-C, other than those in Paragraph 6, shall be subject to the following procedures. Disputes within the meaning of this paragraph include disputes between the Contractor (or any of its subcontractors) and the HA, or HUD, or the employees or their representatives, concerning payment of prevailing wage rates or proper classification. The procedures in this section may be initiated upon HUD's own motion, upon referral of the HA, or upon request of the Contractor or subcontractor(s).
- (i) A Contractor and/or subcontractor or other interested party desiring reconsideration of findings of violation by the HA or HUD relating to the payment of straight-time prevailing wages or classification of work shall request such reconsideration by letter postmarked within 30 calendar days of the date of notice of findings issued by the HA or HUD. The request shall set

- forth those findings that are in dispute and the reasons, including any affirmative defenses, with respect to the violations. The request shall be directed to the appropriate HA or HUD official in accordance with instructions contained in the notice of findings or, if the notice does not specify to whom a request should be made, to the Regional Labor Relations Officer (HUD). The HA or HUD official shall, within 60 days (unless otherwise indicated in the notice of findings) after receipt of a timely request for reconsideration, issue a written decision on the findings of violation. The written decision on reconsideration shall contain instructions that any appeal of the decision shall be addressed to the Regional Labor Relations Officer by letter postmarked within 30 calendar days after the date of the decision. In the event that the Regional Labor Relations Officer was the deciding official on reconsideration, the appeal shall be directed to the Director, Office of Labor Relations (HUD). Any appeal must set forth the aspects of the decision that are in dispute and the reasons, including any affirmative defenses, with respect to the violations. The Regional Labor Relations Officer shall, within 60 days (unless otherwise indicated in the decision on reconsideration) after receipt of a timely appeal, issue a written decision on the findings. A decision of the Regional Labor Relations Officer may be appealed to the Director, Office of Labor Relations, by letter postmarked within 30 days of the Regional Labor Relations Officer's decision. Any appeal to the Director must set forth the aspects of the prior decision(s) that are in dispute and the reasons. The decision of the Director, Office of Labor Relations, shall be final.
- (b) Disputes arising out of the labor standards provisions of paragraph 6 shall not be subject to paragraph 5(a) of this form HUD-5370C. Such disputes shall be resolved in accordance with the procedures of the U.S. Department of Labor set forth in 29 CFR Parts 5, 6 and 7. Disputes within the meaning of this paragraph 5(b) include disputes between the Contractor (or any of its subcontractors) and the HA, HUD, the U.S. Department of Labor, or the employees or their representatives.

## 6. Contract Work Hours and Safety Standards Act

The provisions of this paragraph 6 are applicable only where the amount of the prime contract exceeds \$100,000. As used in this paragraph, the terms "laborers" and "mechanics" includes watchmen and guards.

- (a) **Overtime requirements.** No Contractor or subcontractor contracting for any part of the Contract work which may require or involve the employment of laborers or mechanics shall require or permit any such laborer or mechanic in any workweek in which he or she is employed on such work to work in excess of 40 hours in such workweek unless such laborer or mechanic receives compensation at a rate not less than one and one-half times the basic rate of pay for all hours worked in excess of 40 hours in such workweek.
- (b) **Violation; liability for unpaid wages; liquidated damages.** In the event of any violation of the provisions set forth in paragraph 6(a), the Contractor and any

---

subcontractor responsible therefor shall be liable for the unpaid wages. In addition, such Contractor and subcontractor shall be liable to the United States (in the case of work done under contract for the District of Columbia or a territory, to the District or to such territory), for liquidated damages. Such liquidated damages shall be computed with respect to each individual laborer or mechanic, including watchmen and guards, employed in violation of the provisions set forth in paragraph (a) of this clause, in the sum of \$10 for each calendar day on which such individual was required or permitted to work in excess of the standard workweek of 40 hours without payment of the overtime wages required by provisions set forth in paragraph (a) of this clause.

- (c) **Withholding for unpaid wages and liquidated damages.** HUD or its designee shall upon its own action or upon written request of an authorized representative of the U.S. Department of Labor withhold or cause to be withheld, from any moneys payable on account of work performed by the Contractor or subcontractor under any such Contract or any federal contract with the same prime Contractor, or any other federally-assisted contract subject to the Contract Work Hours and Safety Standards Act, which is held by the same prime Contractor such sums as may be determined to be necessary to satisfy any liabilities of such Contractor or subcontractor for unpaid wages and liquidated damages as provided in the provisions set forth in paragraph (b) of this clause.

## **7. Subcontracts**

The Contractor or subcontractor shall insert in any subcontracts all the provisions contained in this Section II and also a clause requiring the subcontractors to include these provisions in any lower tier subcontracts. The prime Contractor shall be responsible for the compliance by any subcontractor or lower tier subcontractor with all the provisions contained in these clauses.

## **8. Non-Federal Prevailing Wage Rates**

Any prevailing wage rate (including basic hourly rate and any fringe benefits), determined under state law to be prevailing, with respect to any employee in any trade or position employed under the Contract, is inapplicable to the contract and shall not be enforced against the Contractor or any subcontractor, with respect to employees engaged under the contract whenever such non-Federal prevailing wage rate, exclusive of any fringe benefits, exceeds the applicable wage rate determined by the Secretary of HUD to be prevailing in the locality with respect to such trade or position.

## SUPPLEMENTARY CONDITIONS TO THE CONSTRUCTION CONTRACT

U.S. Department of Housing  
and Urban Development  
Office of Housing

OMB Approval No. 2502-0598  
(Exp. 12/31/2027)

The public reporting burden for this collection of information is estimated to average 0.2 hours per response, including the time for reviewing instructions, searching existing data sources, gathering, and maintaining the data needed, and completing and reviewing the collection of information. Comments regarding the accuracy of this burden estimate and any suggestions for reducing this burden can be sent to U.S. Department of Housing and Urban Development, Office of the Chief Data Officer, 451 7th St SW, Room 8210, Washington, DC 20410-5000. Do not send completed forms to this address. This agency may not conduct or sponsor, and a person is not required to respond to, a collection of information unless the collection displays a valid OMB control number. HUD collects this information to obtain supportive documentation that must be submitted to HUD for approval. HUD uses this information to ensure that viable projects are developed and maintained. This information is required to obtain benefits derived from the National Housing Act Multifamily Mortgage Insurance Programs. This information collected is authorized under Title II of the National Housing Act (12 USC 1701 et seq.) and the regulations at 24 CFR 200 et seq., and no confidentiality is assured.

**Warning:** Any person who knowingly presents a false, fictitious, or fraudulent statement or claim in a matter within the jurisdiction of the U.S. Department of Housing and Urban Development is subject to criminal penalties, civil liability, and administrative sanctions.

### Article 1: Labor Standards

**A. Applicability.** The Project or program to which the construction work covered by this Contract pertains is being assisted or insured by the United States of America, and the following Federal Labor Standards Provisions are included in this Contract or related instrument pursuant to the provisions applicable to such Federal assistance or insurance. Any statute or regulation contained herein shall also include any subsequent amendment or successor statute or regulation. The terms of this Supplementary Conditions to the Construction Contract (HUD-92554M) takes precedence over all provisions of the "General Conditions of the Contract for Construction" (AIA Document A201) inconsistent with said Supplementary Conditions.

**B. Minimum Wages.** Pursuant to Section 212 of the National Housing Act, as amended, 12 U.S.C. 1715c, the minimum wage provisions contained in this paragraph B do not apply to those projects with Security Instruments insured under Section 221(h)(1) designed for less than 9 families and they do not apply to those projects with Security Instruments insured under either Section 220 or 233 designed for less than 12 families.

1. (i) All laborers and mechanics employed or working upon the site of the work (or under the United States Housing Act of 1937 or under the Housing Act of 1949 in the construction or development of the Project) shall be paid unconditionally and not less often than once a week, and without subsequent deduction or rebate on any account (except such payroll deductions as are permitted by regulations issued by the Secretary of Labor under the Copeland Act (29 CFR Part 3)), the full amount of wages and bona fide fringe benefits (or cash equivalents thereof) due at time of payment computed at rates not less than those contained in the wage determination of the Secretary of Labor which is attached hereto and made a part hereof, regardless of any contractual relationship which may be alleged to exist between the Contractor and such laborers and mechanics. Contributions made or costs reasonably anticipated for bona fide fringe benefits under Section 1 (b)(2) of the Davis-Bacon Act (40 U.S.C. 3141(2)(B)(ii)) on behalf of laborers or mechanics are considered wages paid to such laborers or

mechanics, subject to the provisions of 29 CFR 5.5(a)(1)(iv); also, regular contributions made or costs incurred for more than a weekly period (but not less often than quarterly) under plans, funds, or programs, which cover the particular weekly period, are deemed to be constructively made or incurred during such weekly period. Such laborers and mechanics shall be paid the appropriate wage rate and fringe benefits on the wage determination for the classification of work actually performed, without regard to skill, except as provided in 29 CFR 5.5(a)(4). Laborers or mechanics performing work in more than one classification may be compensated at the rate specified for each classification for the time actually worked therein: *Provided*, that the employer's payroll records accurately set forth the time spent in each classification in which work is performed. The wage determination (including any additional classification and wage rates conformed under 29 CFR 5.5(a)(1)(ii)) and the Davis-Bacon poster (WH-1321) shall be posted at all times by the Contractor and its subcontractors at the site of the work in a prominent and accessible place where it can be easily seen by the workers.

(ii) (a) Any class of laborers or mechanics that is not listed in the wage determination and that is to be employed under this Contract shall be classified in conformance with the wage determination. HUD shall approve an additional classification and wage rate and fringe benefits only when the following criteria have been met:

- (1) The work to be performed by the classification requested is not performed by a classification in the wage determination; and
- (2) The classification is utilized in the area by the construction industry; and
- (3) The proposed wage rate, including any bona fide fringe benefits, bears a reasonable relationship to the wage rates contained in the wage determination.

(b) If the Contractor and the laborers and mechanics to be employed in the classification (if known), or their representatives, and HUD or its designee agree on the classification and wage rate (including the amount designated for fringe benefits where appropriate), a report of the action taken shall be sent by HUD or its designee to the Administrator of the Wage and Hour Division, U.S. Department of Labor, Washington, D.C. 20210 (“**Administrator**”). The Administrator, or an authorized representative, shall approve, modify, or disapprove every additional classification action within thirty (30) days of receipt and so advise HUD or its designee or shall notify HUD or its designee within the thirty (30) day period that additional time is necessary.

(c) In the event the Contractor, the laborers or mechanics to be employed in the classification or their representatives and HUD or its designee do not agree on the proposed classification and wage rate (including the amount designated for fringe benefits, where appropriate), HUD or its designee shall refer the questions, including the views of all interested parties and the recommendation of HUD or its designee, to the Administrator for determination. The Administrator, or an authorized representative, shall issue a determination within thirty (30) days of receipt and so advise HUD or its

designee or shall notify HUD or its designee within the thirty (30) day period that additional time is necessary.

(d) The wage rate (including fringe benefits where appropriate) determined pursuant to subparagraphs B.1.(ii)(b) or (c) of this Article, shall be paid to all workers performing work in the classification under this Contract from the first day on which work is performed in the classification.

(iii) Whenever the minimum wage rate prescribed in the Contract for a class of laborers or mechanics includes a fringe benefit that is not expressed as an hourly rate, the Contractor shall either pay the benefit as stated in the wage determination or shall pay another bona fide fringe benefit or an hourly cash equivalent thereof.

(iv) If the Contractor does not make payments to a trustee or other third person, the Contractor may consider as part of the wages of any laborer or mechanic the amount of any costs reasonably anticipated in providing bona fide fringe benefits under a plan or program, *Provided*, That the Secretary of Labor has found, upon the written request of the Contractor, that the applicable standards of the Davis-Bacon Act have been met. The Secretary of Labor may require the Contractor to set aside in a separate account assets for the meeting of obligations under the plan or program.

**2. Withholding.** HUD or its designee shall upon its own action or upon written request of an authorized representative of the U.S. Department of Labor withhold or cause to be withheld from the Contractor under this Contract or any other Federal contract with the same prime contractor, or any other Federally-assisted contract subject to Davis-Bacon prevailing wage requirements, which is held by the same prime contractor, so much of the accrued payments or advances as may be considered necessary to pay laborers and mechanics, including apprentices, trainees and helpers, employed by the Contractor or any subcontractor the full amount of wages required by the Contract. In the event of failure to pay any laborer or mechanic, including any apprentice, trainee or helper, employed or working on the site of the work (or under the United States Housing Act of 1937 or under the Housing Act of 1949 in the construction or development of the Project), all or part of the wages required by the Contract, HUD or its designee may, after written notice to the Contractor, sponsor, applicant, or Owner, take such action as may be necessary to cause the suspension of any further payment, advance, or guarantee of funds until such violations have ceased. HUD or its designee may, after written notice to the Contractor, disburse such amounts withheld for and on account of the Contractor or subcontractor to the respective employees to whom they are due.

### **3. Payrolls, records, and certifications.**

(i) Payrolls and basic records relating thereto shall be maintained by the Contractor during the course of the work and preserved for a period of three years thereafter for all laborers and mechanics working at the site of the work (or under the United States Housing Act of 1937, or under the Housing Act of 1949, in the construction or development of the Project). Such records shall contain the name,

address, and social security number of each such worker, his or her correct classification, hourly rates of wages paid (including rates of contributions or costs anticipated for bona fide fringe benefits or cash equivalents thereof of the types described in Section 1 (b)(2)(B) of the Davis-Bacon Act (40 U.S.C. 3141(2)(B)(ii))), daily and weekly number of hours worked, deductions made and actual wages paid. Whenever the Secretary of Labor has found under 29 CFR 5.5(a)(1)(iv) that the wages of any laborer or mechanic include the amount of any costs reasonably anticipated in providing benefits under a plan or program described in Section 1 (b)(2)(B) of the Davis-Bacon Act (40 U.S.C. 3141(2)(B)(ii)), the Contractor shall maintain records which show that the commitment to provide such benefits is enforceable, that the plan or program is financially responsible, and that the plan or program has been communicated in writing to the laborers or mechanics affected, and records which show the costs anticipated or the actual cost incurred in providing such benefits. Contractors employing apprentices or trainees under approved programs shall maintain written evidence of the registration of apprenticeship programs and certification of trainee programs, the registration of the apprentices and trainees, and the ratios and wage rates prescribed in the applicable programs.

(ii)(a) The Contractor shall submit weekly for each week in which any contract work is performed a copy of all payrolls to HUD or its designee if the agency is a party to the Contract, but if the agency is not such a party, the Contractor shall submit the payrolls to the applicant, sponsor, or Owner, as the case may be, for transmission to HUD or its designee. The payrolls submitted shall set out accurately and completely all of the information required to be maintained under 29 CFR 5.5(a)(3)(i), except that full social security numbers and home addresses shall not be included on weekly transmittals. Instead the payrolls shall only need to include an individually identifying number for each employee (e.g., the last four digits of the employee's social security number). The required weekly payroll information may be submitted in any form desired, whether paper (Optional Form WH-347 is available for this purpose from the Wage and Hour Division Web site at <http://www.dol.gov/whd/forms/wh347.pdf> or its successor site), or electronically pursuant to Program Obligations. The prime contractor is responsible for the submission of copies of payrolls by all subcontractors. Contractors and subcontractors shall maintain the full social security number and current address of each covered worker, and shall provide them upon request to HUD or its designee if the agency is a party to the Contract, but if the agency is not such a party, the Contractor will submit the payrolls to the applicant sponsor, or Owner, as the case may be, for transmission to HUD or its designee, the Contractor, or the Wage and Hour Division of the U.S. Department of Labor for purposes of an investigation or audit of compliance with prevailing wage requirements. It is not a violation of this subparagraph for a prime contractor to require a subcontractor to provide addresses and social security numbers to the prime contractor for its own records, without weekly submission to HUD or its designee.

(b) Each payroll submitted shall be accompanied by a "Statement of Compliance," signed by the Contractor or subcontractor or his or her agent who pays or supervises the payment of the persons employed under the Contract and shall certify the following:

(1) That the payroll for the payroll period contains the information required to be provided under 29 CFR 5.5(a)(3)(ii), the appropriate information is being maintained under 29 CFR 5.5(a)(3)(i), and that such information is correct and complete.

(2) That each laborer or mechanic (including each helper, apprentice, and trainee) employed on the Contract during the payroll period has been paid the full weekly wages earned, without rebate, either directly or indirectly, and that no deductions have been made either directly or indirectly from the full wages earned, other than permissible deductions as set forth in 29 CFR Part 3;

(3) That each laborer or mechanic has been paid not less than the applicable wage rates and fringe benefits or cash equivalents for the classification of work performed, as specified in the applicable wage determination incorporated into the Contract.

(c) The weekly submission of a properly executed certification set forth on the reverse side of Optional Form WH-347 shall satisfy the requirement for submission of the "Statement of Compliance" required by subparagraph B.3.(ii)(b) of this Article.

(d) The falsification of any of the above certifications may subject the Contractor or subcontractor to civil or criminal prosecution under Section 1001 of Title 18 and Sections 3801 et seq of Title 31 of the United States Code.

(iii) The Contractor or subcontractor shall make the records required under subparagraph B.3.(i) of this Article available for inspection, copying, or transcription by authorized representatives of HUD or its designee or the U.S. Department of Labor, and shall permit such representatives to interview employees during working hours on the job. If the Contractor or subcontractor fails to submit the required records or to make them available, HUD or its designee may, after written notice to the Contractor, sponsor, applicant, or Owner, take such action as may be necessary to cause the suspension of any further payment, advance, or guarantee of funds. Furthermore, failure to submit the required records upon request or to make such records available may be grounds for debarment action pursuant to 29 CFR 5.12.

#### **4. Apprentices and Trainees.**

(i) **Apprentices.** Apprentices shall be permitted to work at less than the predetermined rate for the work they performed when they are employed pursuant to and individually registered in a bona fide apprenticeship program registered with the U.S. Department of Labor, Employment and Training Administration, Office of

Apprenticeship, or with a State Apprenticeship Agency recognized by such Office, or if a person is employed in his or her first ninety (90) days of probationary employment as an apprentice in such an apprenticeship program, who is not individually registered in the program, but who has been certified by the Office of Apprenticeship, or a State Apprenticeship Agency (where appropriate) to be eligible for probationary employment as an apprentice. The allowable ratio of apprentices to journeymen on the job site in any craft classification shall not be greater than the ratio permitted to the Contractor as to the entire work force under the registered program. Any worker listed on a payroll at an apprentice wage rate, who is not registered or otherwise employed as stated above, shall be paid not less than the applicable wage rate on the wage determination for the classification of work actually performed. In addition, any apprentice performing work on the job site in excess of the ratio permitted under the registered program shall be paid not less than the applicable wage rate on the wage determination for the work actually performed. Where the Contractor is performing construction on a project in a locality other than that in which its program is registered, the ratios and wage rates (expressed in percentages of the journeyman's hourly rate) specified in the Contractor's or subcontractor's registered program shall be observed. Every apprentice must be paid at not less than the rate specified in the registered program for the apprentice's level of progress, expressed as a percentage of the journeymen hourly rate specified in the applicable wage determination. Apprentices shall be paid fringe benefits in accordance with the provisions of the apprenticeship program. If the apprenticeship program does not specify fringe benefits, apprentices must be paid the full amount of fringe benefits listed on the wage determination for the applicable classification. If the Administrator determines that a different practice prevails for the applicable apprentice classification, fringes shall be paid in accordance with that determination. In the event the Office of Apprenticeship, or a State Apprenticeship Agency recognized by such Office, withdraws approval of an apprenticeship program, the Contractor shall no longer be permitted to utilize apprentices at less than the applicable predetermined rate for the work performed until an acceptable program is approved.

(ii) **Trainees.** Except as provided in 29 CFR 5.16, trainees shall not be permitted to work at less than the predetermined rate for the work performed unless they are employed pursuant to and individually registered in a program which has received prior approval, evidenced by formal certification by the U.S. Department of Labor, Employment and Training Administration. The ratio of trainees to journeymen on the job site shall not be greater than permitted under the plan approved by the Employment and Training Administration. Every trainee must be paid at not less than the rate specified in the approved program for the trainee's level of progress, expressed as a percentage of the journeyman's hourly rate specified in the applicable wage determination. Trainees shall be paid fringe benefits in accordance with the provisions of the trainee program. If the trainee program does not mention fringe benefits, trainees shall be paid the full amount of fringe benefits listed on the wage determination unless the Administrator of the Wage and Hour Division determines that there is an apprenticeship program associated with the corresponding journeyman wage rate on the wage determination which provides for less than full fringe benefits for apprentices. Any employee listed on the payroll at a trainee rate who is not registered and

participating in a training plan approved by the Employment and Training Administration shall be paid not less than the applicable wage rate on the wage determination for the classification of work actually performed. In addition, any trainee performing work on the job site in excess of the ratio permitted under the registered program shall be paid not less than the applicable wage rate on the wage determination for the work actually performed. In the event the Employment and Training Administration withdraws approval of a training program, the Contractor shall no longer be permitted to utilize trainees at less than the applicable predetermined rate for the work performed until an acceptable program is approved.

(iii) **Equal employment opportunity.** The utilization of apprentices, trainees and journeymen under 29 CFR Part 5 shall be in conformity with the equal employment opportunity requirements of Executive Order 11246, as amended, and 29 CFR Part 30.

**5. Compliance with Copeland Act Requirements.** The Contractor shall comply with the requirements of 29 CFR Part 3, which are incorporated by reference in this Contract.

**6. Subcontracts.** The Contractor or subcontractor shall insert in any subcontracts the clauses set forth in subparagraphs 1 through 10 of this paragraph B and such other clauses as HUD or its designee may by appropriate instructions require, and a copy of the applicable prevailing wage determination, and also a clause requiring the subcontractors to include these clauses in any lower tier subcontracts. The prime contractor shall be responsible for the compliance by any subcontractor or lower tier subcontractor with all Contract clauses referenced in this subparagraph.

**7. Contract termination and debarment.** A breach of the Contract clauses in 29 CFR 5.5 may be grounds for termination of the Contract, and for debarment as a contractor or a subcontractor as provided in 29 CFR 5.12.

**8. Compliance with Davis-Bacon and Related Act Requirements.** All rulings and interpretations of the Davis-Bacon and Related Acts contained in 29 CFR Parts 1, 3, and 5 are herein incorporated by reference in this Contract.

**9. Disputes concerning labor standards.** Disputes arising out of the labor standards provisions of this Contract shall not be subject to the general disputes clause of this Contract. Such disputes shall be resolved in accordance with the procedures of the U.S. Department of Labor set forth in 29 CFR Parts 5, 6, and 7. Disputes within the meaning of this clause include disputes between the Contractor (or any of its subcontractors) and HUD or its designee, the U.S. Department of Labor, or the employees or their representatives.

**10. Certification of Eligibility.**

(i) By entering into this Contract, the Contractor certifies that neither it (nor he or she) nor any person or firm who has an interest in the Contractor's firm is a person or firm ineligible to be awarded Government contracts by virtue of Section 3(a) of the

Davis-Bacon Act (40 U.S.C. 3144(b)(2)) or 29 CFR 5.12(a)(1) or to be awarded HUD contracts or participate in HUD programs pursuant to 24 CFR Part 24.

(ii) No part of this Contract shall be subcontracted to any person or firm ineligible for award of a Government contract by virtue of Section 3(a) of the Davis-Bacon Act (40 U.S.C. 3144(b)(2)) or 29 CFR 5.12(a)(1) or to be awarded HUD contracts or participate in HUD programs pursuant to 24 CFR Part 24.

(iii) The penalty for making false statements is prescribed in the U.S. Criminal Code, 18 U.S.C. 1001. Additionally, U.S. Criminal Code, Section 1010, Title 18, U.S.C., "Federal Housing Administration transactions", provides in part: "Whoever, for the purpose of . . . influencing in any way the action of such Department . . . makes, passes, utters or publishes any statement, knowing the same to be false . . . shall be fined under this title or imprisoned not more than two years, or both."

### C. **Contract Work Hours and Safety Standards Act.**

1. **Applicability and Definitions.** This paragraph C of Article 1 is applicable only if a direct form of federal assistance is involved, such as Section 8, Section 202/811 Capital Advance, grants etc., and is applicable only where the prime contract is in an amount greater than \$100,000. As used in this paragraph C, the terms "laborers" and "mechanics" include watchmen and guards.

2. **Overtime requirements.** No contractor or subcontractor contracting for any part of the Contract work that may require or involve the employment of laborers or mechanics shall require or permit any such laborer or mechanic in any workweek in which he or she is employed on such work to work in excess of forty (40) hours in such workweek unless such laborer or mechanic receives compensation at a rate not less than one and one-half times the basic rate of pay for all hours worked in excess of forty (40) hours in such workweek.

3. **Violation; liability for unpaid wages; liquidated damages.** In the event of any violation of the immediately preceding subparagraph C.2, the Contractor and any subcontractor responsible therefore shall be liable for the unpaid wages. In addition, the Contractor and subcontractor shall be liable to the United States (in the case of work done under contract for the District of Columbia or a territory, to such District or to such territory) for liquidated damages, which shall be computed with respect to each individual laborer or mechanic, including watchmen and guards, employed in violation of such subparagraph, at a rate determined and published by the U.S. Department of Labor for each calendar day on which such individual was required or permitted to work in excess of the standard workweek of forty (40) hours without payment of the overtime wages required by the clause set forth in such subparagraph. The U.S. Department of Labor posts current civil money penalty rates at: <https://www.dol.gov/whd/govcontracts/cwhssa.htm#cmp>.

**4. Withholding for unpaid wages and liquidated damages.** HUD or its designee shall, upon its own action or upon written request of an authorized representative of the U.S. Department of Labor, withhold or cause to be withheld from any moneys payable on account of work performed by the Contractor or subcontractor under any such contract, or under any other Federal contract with the same prime contractor, or under any other Federally-assisted contract subject to the Contract Work Hours and Safety Standards Act which is held by the same prime contractor such sums as may be determined to be necessary to satisfy any liabilities of such Contractor or subcontractor for unpaid wages and liquidated damages as provided in the clause set forth in subparagraph 3 of this paragraph C.

**5. Subcontracts.** The Contractor or subcontractor shall insert in any subcontracts the clauses set forth in subparagraphs 1 through 5 of this paragraph C and also a clause requiring the subcontractors to include these clauses in any lower tier subcontracts. The prime contractor shall be responsible for compliance by any subcontractor or lower tier subcontractor with the clauses set forth in such subparagraphs 1 through 5.

#### **D. Certification.**

For projects with Security Instruments insured under the National Housing Act, as amended, that are subject to paragraph B of this Article 1, the Contractor is required to execute the Contractor's Prevailing Wage Certificate within HUD-92448 as a condition precedent to insurance by HUD of the Loan, or an advance thereof, made or to be made by the Lender in connection with the construction of the Project.

### **Article 2: Equal Employment Opportunity**

**A. Applicability.** This Article 2 applies to any contract for construction work, or modification thereof, as defined in the regulations of the Secretary of Labor at 41 CFR Chapter 60, which is paid for in whole or in part with funds obtained from the Federal Government or borrowed on the credit of the Federal Government pursuant to a grant, contract, loan insurance, or guarantee, or undertaken pursuant to any Federal program involving such grant, contract, loan, insurance, or guarantee.

**B.** The Contractor shall not discriminate against any employee or applicant for employment because of race, color, religion, sex, sexual orientation, gender identity, age, disability, or national origin. The Contractor shall take affirmative action to ensure that applicants are employed, and that employees are treated during employment without regard to their race, color, religion, sex, sexual orientation, gender identity, age, disability or national origin. Such action shall include, but not be limited to the following: employment, upgrading, demotion, or transfer; recruitment or recruitment advertising; layoff or termination; rates of pay or other forms of compensation; and selection for training including apprenticeship. The Contractor agrees to post in conspicuous places available to employees and applicants for employment notices to be provided setting forth the provisions of this nondiscrimination clause.

C. The Contractor shall, in all solicitations or advertisements for employees placed by or on behalf of the Contractor state that all qualified applicants shall receive consideration for employment without regard to race, color, religion, sex, sexual orientation, gender identity, age, disability, or national origin.

D. The Contractor shall send to each labor union or representative of workers with which it has a collective bargaining agreement or other contract or understanding a notice to be provided advising the said labor union or workers representatives of the Contractor's commitments hereunder, and shall post copies of the notice in conspicuous places available to employees and applicants for employment.

E. The Contractor shall comply with all provisions of Executive Order 11246 of September 24, 1965 and of the rules, regulations, and relevant orders of the Secretary of Labor.

F. The Contractor shall furnish all information and reports required by Executive Order 11246 of September 24, 1965, and by rules, regulations, and orders of the Secretary of Labor, or pursuant thereto, and shall permit access to its books, records, and accounts by the Secretary of Labor for purposes of investigation to ascertain compliance with such rules, regulations, and orders.

G. In the event of the Contractor's noncompliance with the nondiscrimination clauses of this Contract or with any of the said rules, regulations, or orders, this Contract may be canceled, terminated, or suspended in whole or in part and Contractor may be declared ineligible for further government contracts or federally assisted construction contracts in accordance with procedures authorized in Executive Order 11246 of September 24, 1965, and such other sanctions may be imposed and remedies invoked as provided in Executive Order 11246 of September 24, 1965, or by rule, regulations or order of the Secretary of Labor, or as otherwise provided by law.

H. The Contractor shall include the provisions of paragraphs A through H of this Article 2 in every subcontract or purchase order unless exempted by rules, regulations, or orders of the Secretary of Labor issued pursuant to Section 204 of Executive Order 11246 of September 24, 1965, so that such provisions shall be binding upon each subcontractor or vendor. The Contractor shall take such action with respect to any subcontract or purchase order as HUD or the Secretary of Labor may direct as a means of enforcing such provisions, including sanctions for noncompliance. *Provided, however,* that in the event the Contractor becomes involved in, or is threatened with, litigation with a subcontractor or vendor as a result of such direction by HUD or the Secretary of Labor, the Contractor may request the United States to enter into such litigation to protect the interests of the United States.

### **Article 3: Equal Opportunity for Businesses and Lower Income Persons Located Within the Project Area**

A. This Article 3 is applicable to projects covered by Section 3, as defined in 24 CFR Part 135.

B. The work to be performed under this Contract is on a project assisted under a program providing Federal financial assistance from HUD and is subject to the requirements of Section 3 of the Housing and Urban Development Act of 1968, as amended, 12 U.S.C. 1701u. Section 3 requires that to the greatest extent feasible

opportunities for training and employment be given to low and very-low income residents of the unit of local government or the metropolitan area (or non-metropolitan county) as determined by HUD in which the Project is located and contracts for work in connection with the Project be awarded to business concerns which are located in, or owned in substantial part by persons residing in the same metropolitan area (or non-metropolitan county) as the Project.

#### **Article 4: Health and Safety**

A. This Article 4 is applicable only where the prime contract is in an amount greater than \$100,000.

B. No laborer or mechanic shall be required to work in surroundings or under working conditions which are unsanitary, hazardous, or dangerous to his or her health and safety as determined under construction safety and health standards promulgated by the Secretary of Labor by regulation.

C. The Contractor shall comply with all regulations issued by the Secretary of Labor pursuant to 29 CFR Part 1926, and failure to comply may result in imposition of sanctions pursuant to the Contract Work Hours and Safety Standards Act, 40 USC 3701 et seq.

D. The Contractor shall include the provisions of this Article 4 in every subcontract so that such provisions shall be binding on each subcontractor. The Contractor shall take such action with respect to any subcontract as HUD or the Secretary of Labor shall direct as a means of enforcing such provisions.

# Supplementary Conditions of the Contract for Construction

U.S. Department of Housing  
and Urban Development  
Office of Housing  
Federal Housing Commissioner

OMB Approval No. 2502-0470  
(Expires 12/31/2016)

Public reporting burden for this collection of information is estimated to average 30 minutes per response, including the time for reviewing instructions, searching existing data sources, gathering and maintaining the data needed, and completing and reviewing the collection of information. This information is required to obtain benefits and voluntary. HUD may not collect this information, and you are not required to complete this form, unless it displays a currently valid OMB control number.

This information collection is necessary to ensure that viable projects are developed. It is important to obtain information from applicants to assist HUD in determining if nonprofit organizations initially funded continue to have the financial and administrative capacity needed to develop a project and that the project design meets the needs of the residents. The Department will use this information to set forth the obligations of the contractor or subcontractor performing under the covered contract. This information is required in order to obtain benefits. This information is considered non-sensitive and no assurance of confidentiality is provided.

## Article 1 – Labor Standards

### Instructions

Whenever only FHA mortgage insurance is involved, use paragraph (A) and (C) of Article 1 – Labor Standards. Whenever any direct form of assistance (Section 8, Section 202/811 Capital Advance, grants etc.) is involved, use paragraphs (A) and (B) and (C) of Article 1 – Labor Standards.

### Applicability

The Project or Program to which the construction work covered by this contract pertains is being assisted or insured by the United States of America and the following Federal Labor Standards Provisions are included in this Contract or related instrument pursuant to the provisions applicable to such Federal assistance or insurance.

**A. 1. (i) Minimum Wages.** All laborers and mechanics employed or working upon the site of the work (or under the United States Housing Act of 1937 or under the Housing Act of 1949 in the construction or development of the project), will be paid unconditionally and not less often than once a week, and without subsequent deduction or rebate on any account (except such payroll deductions as are permitted by regulations issued by the Secretary of Labor under the Copeland Act (29 CFR Part 3), the full amount of wages and bona fide fringe benefits (or cash equivalents thereof) due at time of payment computed at rates not less than those contained in the wage determination of the Secretary of Labor which is attached hereto and made a part hereof, regardless of any contractual relationship which may be alleged to exist between the contractor and such laborers and mechanics. Contributions made or costs reasonably anticipated for bona fide fringe benefits under Section 1(b)(2) of the Davis-Bacon Act on behalf of laborers or mechanics are considered wages paid to such laborers or mechanics, subject to the provisions of 29 CFR 5.5(a)(1)(iv); also, regular contributions made or costs incurred for more than a weekly period (but not less often than quarterly) under plans, funds, or programs, which cover the particular weekly period, are deemed to be constructively made or incurred during such weekly period.

Such laborers and mechanics shall be paid the appropriate wage rate and fringe benefits on the wage determination for the classification of work actually performed, without regard to skill, except as provided in 29 CFR Part 5.5(a)(4). Laborers or mechanics performing work in more than one classification may be compensated at the rate specified for each classification for the time actually worked therein: Provided, That the employer's payroll records accurately set forth the time spent in each classification in which work is performed. The wage determination (including any additional classification and wage rates conformed under 29 CFR Part 5.5(a)(1)(ii) and the Davis-Bacon poster (WH-1321) shall be posted at all times by the contractor and its subcontractors at the site of the work in a prominent and accessible place where it can be easily seen by the workers.

(ii) (a) Any class of laborers or mechanics which is not listed in the wage determination and which is to be employed under the contract shall be classified in conformance with the wage determination. HUD shall approve an additional classification and wage rate and fringe benefits therefore only when the following criteria have been met:

(1) The work to be performed by the classification

requested is not performed by a classification in the wage determination; and

(2) The classification is utilized in the area by the construction industry; and

(3) The proposed wage rate, including any bona fide fringe benefits, bears a reasonable relationship to the wage rates contained in the wage determination.

(b) If the contractor and the laborers and mechanics to be employed in the classification (if known), or their representatives, and HUD or its designee agree on the classification and wage rate (including the amount designated for fringe benefits where appropriate), a report of the action taken shall be sent by HUD or its designee to the Administrator of the Wage and Hour Division, Employment Standards Administration, U.S. Department of Labor, Washington, D.C. 20210. The Administrator, or an authorized representative, will approve, modify, or disapprove every additional classification action within 30 days of receipt and so advise HUD or its designee or will notify HUD or its designee within the 30-day period that additional time is necessary. (Approved by the Office of Management and Budget under OMB control number 1215-0140.)

(c) In the event the contractor, the laborers or mechanics to be employed in the classification or their representatives, and HUD or its designee do not agree on the proposed classification and wage rate (including the amount designated for fringe benefits, where appropriate), HUD or its designee shall refer the questions, including the views of all interested parties and the recommendation of HUD or its designee, to the Administrator for determination. The Administrator, or an authorized representative, will issue a determination within 30 days of receipt and so advise HUD or its designee or will notify HUD or its designee within the 30-day period that additional time is necessary. (Approved by the Office of Management and Budget under OMB Control Number 1215-0140.)

(d) The wage rate (including fringe benefits where appropriate) determined pursuant to subparagraphs A.1.(ii)(b) or (c) of this paragraph, shall be paid to all workers performing work in the classification under this contract from the first day on which work is performed in the classification.

(iii) Whenever the minimum wage rate prescribed in the contract for a class of laborers or mechanics includes a fringe benefit which is not expressed as an hourly rate, the contractor shall either pay the benefit as stated in the wage determination or shall pay another bona fide fringe benefit or an hourly cash equivalent thereof.

(iv) If the contractor does not make payments to a trustee or other third person, the contractor may consider as part of the wages of any laborer or mechanic the amount of any costs reasonably anticipated in providing bona fide fringe benefits under a plan or program, Provided, That the Secretary of Labor has found, upon the written request of the contractor, that the applicable standards of the Davis-Bacon Act have been met. The Secretary of Labor may require the contractor to set aside in a separate account assets for the meeting of obligations under the plan or program. (Approved by the Office of Management and Budget under OMB Control Number 1215-0140.)

**2. Withholding.** HUD or its designee shall upon its own action or upon written request of an authorized representative of the Department of Labor withhold or cause to be withheld from the contractor under this contract or any other Federal contract with the

same prime contractor, or any other Federally-assisted contract subject to Davis-Bacon prevailing wage requirements, which is held by the same prime contractor so much of the accrued payments or advances as may be considered necessary to pay laborers and mechanics, including apprentices, trainees and helpers, employed by the contractor or any subcontractor the full amount of wages required by the contract. In the event of failure to pay any laborer or mechanic, including any apprentice, trainee or helper, employed or working on the site of the work (or under the United States Housing Act of 1937 or under the Housing Act of 1949 in the construction or development of the project), all or part of the wages required by the contract, HUD or its designee may, after written notice to the contractor, sponsor, applicant, or owner, take such action as may be necessary to cause the suspension of any further payment, advance, or guarantee of funds until such violations have ceased. HUD or its designee may, after written notice to the contractor, disburse such amounts withheld for and on account of the contractor or subcontractor to the respective employees to whom they are due. The Comptroller General shall make such disbursements in the case of direct Davis-Bacon Act contracts.

**3. (i) Payrolls and basic records.** Payrolls and basic records relating thereto shall be maintained by the contractor during the course of the work and preserved for a period of three years thereafter for all laborers and mechanics working at the site of the work (or under the United States Housing Act of 1937, or under the Housing Act of 1949, in the construction or development of the project). Such records shall contain the name, address, and social security number of each such worker, his or her correct classification, hourly rates of wages paid (including rates of contributions or costs anticipated for bona fide fringe benefits or cash equivalents thereof of the types described in Section 1(b)(2)(B) of the Davis-Bacon Act), daily and weekly number of hours worked, deductions made and actual wages paid. Whenever the Secretary of Labor has found under 29 CFR 5.5(a)(1)(iv) that the wages of any laborer or mechanic include the amount of any costs reasonably anticipated in providing benefits under a plan or program described in Section 1(b)(2)(B) of the Davis-Bacon Act, the contractor shall maintain records which show that the commitment to provide such benefits is enforceable, that the plan or program is financially responsible, and that the plan or program has been communicated in writing to the laborers or mechanics affected, and records which show the costs anticipated or the actual cost incurred in providing such benefits. Contractors employing apprentices or trainees under approved programs shall maintain written evidence of the registration of apprenticeship programs and certification of trainee programs, the registration of the apprentices and trainees, and the ratios and wage rates prescribed in the applicable programs. (Approved by the Office of Management and Budget under OMB Control Numbers 1215-0140 and 1215-0017.)

**(ii) (a)** The contractor shall submit weekly for each week in which any contract work is performed a copy of all payrolls to HUD or its designee if the agency is a party to the contract, but if the agency is not such a party, the contractor will submit the payrolls to the applicant, sponsor, or owner, as the case may be, for transmission to HUD or its designee. The payrolls submitted shall set out accurately and completely all of the information required to be maintained under 29 CFR Part 5.5(a)(3)(i). This information may be submitted in any form desired. Optional Form WH-347 is available for this purpose and may be purchased from the Superintendent of Documents (Federal Stock Number 029-005-00014-1), U.S. Government Printing Office, Washington, D.C. 20402. The prime contractor is responsible for the submission of copies of payrolls by all subcontractors. (Approved by the Office of Management and Budget under OMB Control Number 1215-0149.)

**(b)** Each payroll submitted shall be accompanied by a "Statement of Compliance," signed by the contractor or subcontractor or his or her agent who pays or supervises the payment of the persons employed under the contract and shall certify the following:

- (1)** That the payroll for the payroll period contains the information required to be maintained under 29 CFR Part 5.5(a)(3)(i) and that such information is correct and complete;
- (2)** That each laborer or mechanic (including each

helper, apprentice, and trainee) employed on the contract during the payroll period has been paid the full weekly wages earned, without rebate, either directly or indirectly, and that no deductions have been made either directly or indirectly from the full wages earned, other than permissible deductions as set forth in 29 CFR Part 3;

**(3)** That each laborer or mechanic has been paid not less than the applicable wage rates and fringe benefits or cash equivalents for the classification of work performed, as specified in the applicable wage determination incorporated into the contract.

**(c)** The weekly submission of a properly executed certification set forth on the reverse side of Optional Form WH-347 shall satisfy the requirement for submission of the "Statement of Compliance" required by paragraph A.3.(ii)(b) of this section.

**(d)** The falsification of any of the above certifications may subject the contractor or subcontractor to civil or criminal prosecution under Section 1001 of Title 18 and Section 231 of Title 31 of the United States Code.

**(iii)** The contractor or subcontractor shall make the records required under paragraph A.3.(i) of this section available for inspection, copying, or transcription by authorized representatives of HUD or its designee or the Department of Labor, and shall permit such representatives to interview employees during working hours on the job. If the contractor or subcontractor fails to submit the required records or to make them available, HUD or its designee may, after written notice to the contractor, sponsor, applicant, or owner, take such action as may be necessary to cause the suspension of any further payment, advance, or guarantee of funds. Furthermore, failure to submit the required records upon request or to make such records available may be grounds for debarment action pursuant to 29 CFR Part 5.12.

**4. (i) Apprentices and Trainees. Apprentices.** Apprentices will be permitted to work at less than the predetermined rate for the work they performed when they are employed pursuant to and individually registered in a bona fide apprenticeship program registered with the U.S. Department of Labor, Employment and Training Administration, Bureau of Apprenticeship and Training, or with a State Apprenticeship Agency recognized by the Bureau, or if a person is employed in his or her first 90 days of probationary employment as an apprentice in such an apprenticeship program, who is not individually registered in the program, but who has been certified by the Bureau of Apprenticeship and Training or a State Apprenticeship Agency (where appropriate) to be eligible for probationary employment as an apprentice. The allowable ratio of apprentices to journeymen on the job site in any craft classification shall not be greater than the ratio permitted to the contractor as to the entire work force under the registered program. Any worker listed on a payroll at an apprentice wage rate, who is not registered or otherwise employed as stated above, shall be paid not less than the applicable wage rate on the wage determination for the classification of work actually performed. In addition, any apprentice performing work on the job site in excess of the ratio permitted under the registered program shall be paid not less than the applicable wage rate on the wage determination for the work actually performed. Where a contractor is performing construction on a project in a locality other than that in which its program is registered, the ratios and wage rates (expressed in percentages of the journeyman's hourly rate) specified in the contractor's or subcontractor's registered program shall be observed. Every apprentice must be paid at not less than the rate specified in the registered program for the apprentice's level of progress, expressed as a percentage of the journeymen hourly rate specified in the applicable wage determination. Apprentices shall be paid fringe benefits in accordance with the provisions of the apprenticeship program. If the apprenticeship program does not specify fringe benefits, apprentices must be paid the full amount of fringe benefits listed on the wage determination for the applicable classification. If the Administrator determines that a different practice prevails for the applicable apprentice classification, fringes shall be paid in accordance with that determination. In the event the Bureau

of Apprenticeship and Training, or a State Apprenticeship Agency recognized by the Bureau, withdraws approval of an apprenticeship program, the contractor will no longer be permitted to utilize apprentices at less than the applicable predetermined rate for the work performed until an acceptable program is approved.

**(ii) Trainees.** Except as provided in 29 CFR 5.16, trainees will not be permitted to work at less than the predetermined rate for the work performed unless they are employed pursuant to and individually registered in a program which has received prior approval, evidenced by formal certification by the U.S. Department of Labor, Employment and Training Administration. The ratio of trainees to journeymen on the job site shall not be greater than permitted under the plan approved by the Employment and Training Administration. Every trainee must be paid at not less than the rate specified in the approved program for the trainee's level of progress, expressed as a percentage of the journeyman's hourly rate specified in the applicable wage determination. Trainees shall be paid fringe benefits in accordance with the provisions of the trainee program. If the trainee program does not mention fringe benefits, trainees shall be paid the full amount of fringe benefits listed on the wage determination unless the Administrator of the Wage and Hour Division determines that there is an apprenticeship program associated with the corresponding journeyman wage rate on the wage determination which provides for less than full fringe benefits for apprentices. Any employee listed on the payroll at a trainee rate who is not registered and participating in a training plan approved by the Employment and Training Administration shall be paid not less than the applicable wage rate on the wage determination for the classification of work actually performed. In addition, any trainee performing work on the job site in excess of the ratio permitted under the registered program shall be paid not less than the applicable wage rate on the wage determination for the work actually performed. In the event the Employment and Training Administration withdraws approval of a training program, the contractor will no longer be permitted to utilize trainees at less than the applicable predetermined rate for the work performed until an acceptable program is approved.

**(iii) Equal employment opportunity.** The utilization of apprentices, trainees and journeymen under this part shall be in conformity with the equal employment opportunity requirements of Executive Order 11246, as amended, and 29 CFR Part 30.

**5. Compliance with Copeland Act Requirements.** The contractor shall comply with the requirements of 29 CFR Part 3 which are incorporated by reference in this contract.

**6. Subcontracts.** The contractor or subcontractor will insert in any subcontracts the clauses contained in 29 CFR 5.5(a)(1) through (10) and such other clauses as HUD or its designee may be appropriate instructions require, and also a clause requiring the subcontractors to include these clauses in any lower tier subcontracts. The prime contractor shall be responsible for the compliance by any subcontractor or lower tier subcontractor with all the contract clauses in 29 CFR Part 5.5.

**7. Contract termination; debarment.** A breach of the contract clauses in 29 CFR 5.5 may be grounds for termination of the contract, and for debarment as a contractor and a subcontractor as provided in 29 CFR 5.12.

**8. Compliance with Davis-Bacon and Related Act Requirements.** All rulings and interpretations of the Davis-Bacon and Related Acts contained in 29 CFR Parts 1, 3, and 5 are herein incorporated by reference in this contract.

**9. Disputes concerning labor standards.** Disputes arising out of the labor standards provisions of this contract shall not be subject to the general disputes clause of this contract. Such disputes shall be resolved in accordance with the procedures of the Department of Labor set forth in 29 CFR Parts 5, 6, and 7. Disputes within the meaning of this clause include disputes between the contractor (or any of its subcontractors) and HUD or its designee, the U.S. Department of Labor, or the employees or their representatives.

**10. (i) Certification of Eligibility.** By entering into this contract the contractor certifies neither it (nor he or she) nor any person or firm who has an interest in the contractor's firm is a person or firm

ineligible to be awarded Government contracts by virtue of Section 3(a) of the Davis-Bacon Act or 29 CFR 5.12(a)(1) or to be awarded HUD contracts or participate in HUD programs pursuant to 24 CFR Part 24.

**(ii)** No part of this contract shall be subcontracted to any person or firm ineligible for award of a Government contract by virtue of Section 3(a) of the Davis-Bacon Act or 29 CFR 5.12(a)(1) or to be awarded HUD contracts or participate in HUD programs pursuant to 24 CFR Part 24.

**(iii)** The penalty for making false statements is prescribed in the U.S. Criminal Code, 18 U.S.C. 1001. Additionally, U.S. Criminal Code, Section 1010, Title 18, U.S.C., "Federal Housing Administration transactions", provides in part: "Whoever, for the purpose of . . . influencing in any way the action of such Administration . . . makes, utters or publishes any statement, knowing the same to be false . . . shall be fined not more than \$5,000 or imprisoned not more than two years, or both."

**B. Contract Work Hours and Safety Standards Act.** As used in this paragraph, the terms "laborers" and "mechanics" include watchmen and guards.

**1. Overtime requirements.** No contractor or subcontractor contracting for any part of the contract work which may require or involve the employment of laborers or mechanics shall require or permit any such laborer or mechanic in any workweek in which he or she is employed on such work to work in excess of forty hours in such workweek unless such laborer or mechanic receives compensation at a rate not less than one and one-half times the basic rate of pay for all hours worked in excess of forty hours in such workweek.

**2. Violation; liability for unpaid wages, liquidated damages.** In the event of any violation of the clause set forth in subparagraph (1) of this paragraph, the contractor and any subcontractor responsible therefore shall be liable for the unpaid wages. In addition, such contractor and subcontractor shall be liable to the United States (in the case of work done under contract for the District of Columbia or a territory, to such District or to such territory), for liquidated damages. Such liquidated damages shall be computed with respect to each individual laborer or mechanic, including watchmen and guards, employed in violation of the clause set forth in subparagraph (1) of this paragraph, in the sum of \$10 for each calendar day on which such individual was required or permitted to work in excess of the standard workweek of forty hours without payment of the overtime wages required by the clause set forth in subparagraph (1) of this paragraph.

**3. Withholding for unpaid wages and liquidated damages.** HUD or its designee shall upon its own action or upon written request of an authorized representative of the Department of Labor withhold or cause to be withheld, from any moneys payable on account of work performed by the contractor or subcontractor under any such contract or any other Federal contract with the same prime contractor, or any other Federally-assisted contract subject to the Contract Work Hours and Safety Standards Act, which is held by the same prime contractor such sums as may be determined to be necessary to satisfy any liabilities of such contractor or subcontractor for unpaid wages and liquidated damages as provided in the clause set forth in subparagraph (2) of this paragraph.

**4. Subcontracts.** The contractor or subcontractor shall insert in any subcontracts the clauses set forth in subparagraph (1) through (4) of this paragraph and also a clause requiring the subcontractors to include these clauses in any lower tier subcontracts. The prime contractor shall be responsible for compliance by any subcontractor or lower tier subcontractor with the clauses set forth in subparagraphs (1) through (4) of this paragraph.

**C.** The Contractor will be required to execute FHA Form No. 2403-A, Contractor's Prevailing Wage Certificate, as a condition precedent to insurance by the Federal Housing Administration of that certain mortgage loan, or an advance thereof, made or to be made by the mortgagee in connection with the construction of the project.

## Article 2 – Equal Employment Opportunity

The applicant hereby agrees that it will incorporate or cause to be

incorporated into any contract for construction work, or modification thereof, as defined in the regulations of the Secretary of Labor at 41 CFR Chapter 60, which is paid for in whole or in part with funds obtained from the Federal Government or borrowed on the credit of the Federal Government pursuant to a grant, contract, loan insurance, or guarantee, or undertaken pursuant to any Federal program involving such grant, contract, loan, insurance, or guarantee, the following equal opportunity clause:

During the performance of this contract, the Contractor agrees as follows:

**A.** The Contractor will not discriminate against any employee or applicant for employment because of race, color, religion, sex, or national origin. The Contractor will take affirmative action to ensure that applicants are employed, and that employees are treated during employment without regard to their race, color, religion, sex or national origin. Such action shall include, but not be limited to the following: Employment, upgrading, demotion, or transfer; recruitment or recruitment advertising; layoff or termination; rates of pay or other forms of compensation; and selection for training including apprenticeship. The Contractor agrees to post in conspicuous places available to employees and applicants for employment notices to be provided setting forth the provisions of this nondiscrimination clause.

**B.** The Contractor will, in all solicitations or advertisements for employees placed by or on behalf of the Contractor state that all qualified applicants will receive consideration for employment without regard to race, color, religion, sex, or national origin.

**C.** The Contractor will send to each labor union or representative of workers with which it has a collective bargaining agreement or other contract or understanding a notice to be provided advising the said labor union or workers representatives of the Contractor's commitments hereunder, and shall post copies of the notice in conspicuous places available to employees and applicants for employment.

**D.** The Contractor will comply with all provisions of Executive Order 11246 of September 24, 1965 and of the rules, regulations, and relevant orders of the Secretary of Labor.

**E.** The Contractor will furnish all information and reports required by Executive Order 11246 of September 24, 1965, and by rules, regulations, and orders of the Secretary of Labor, or pursuant thereto, and will permit access to its books, records, and accounts by the Secretary of Labor for purposes of investigation to ascertain compliance with such rules, regulations, and orders.

**F.** In the event of the Contractor's noncompliance with the nondiscrimination clauses of this contract or with any of the said rules, regulations, or orders, this contract may be canceled, terminated, or suspended in whole or in part and the Contractor may be declared ineligible for further government contracts or federally assisted construction contracts in accordance with procedures authorized in Executive Order 11246 of September 24, 1965, and such other sanctions may be imposed and remedies invoked as provided in Executive Order 11246 of September 24, 1965, or by rule, regulations or order of the Secretary of Labor, or as otherwise provided by law.

**G.** The Contractor will include the portion of the sentence immediately preceding paragraph A and the provisions of paragraphs A through G in every subcontract or purchase order unless exempted by rules, regulations, or orders of the Secretary of Labor issued pursuant to Section 204 of Executive Order 11246 of September 24, 1965, so that such provisions will be binding upon each subcontractor or vendor. The Contractor will take such action with respect to any subcontract or purchase order as the Secretary of Housing and Urban Development or the Secretary of Labor may direct as a means of enforcing such provisions, including sanctions for noncompliance. *Provided, however,* that in the event the Contractor becomes involved in, or is threatened with, litigation with a subcontractor or vendor as a result of such direction by the Secretary of Housing and Urban Development or the Secretary of Labor, the Contractor may request the United States to enter into such litigation to protect the interests of the United States.

**H.** The applicant further agrees that it will be bound by the above equal opportunity clause with respect to its own employment practices when it participates in federally assisted construction work:

*Provided, That* if the applicant so participating is a State or local government, the above equal opportunity clause is not applicable to any agency, instrumentality or subdivision of such government which does not participate in work on or under the contract.

**I.** The applicant agrees that it will assist and cooperate actively with the administering agency and the Secretary of Labor in obtaining the compliance of contractors and subcontractors with the equal opportunity clause and the rules, regulations, and relevant orders of the Secretary of Labor, that it will furnish the administering agency and the Secretary of Labor such information as they may require for the supervision of such compliance, and that it will otherwise assist the administering agency in the discharge of the agency's primary responsibility for securing compliance.

**J.** The applicant further agrees that it will refrain from entering into any contract or contract modification subject to Executive Order 11246 of September 24, 1965, with a contractor debarred from, or who has not demonstrated eligibility for, Government contracts and federally assisted construction contracts pursuant to the Executive order and will carry out such sanctions and penalties for violation of the equal opportunity clause as may be imposed upon contractors and subcontractors by the administering agency or the Secretary of Labor pursuant to Part II, Subpart D of the Executive order. In addition, the applicant agrees that if it fails or refuses to comply with these undertakings, the administering agency may take any or all of the following actions: Cancel, terminate, or suspend in whole or in part this grant (contract, loan, insurance, guarantee); refrain from extending any further assistance to the applicant under the program with respect to which the failure or refund occurred until satisfactory assurance of future compliance has been received from such applicant; and refer the case to the Department of Justice for appropriate legal proceedings.

### **Article 3 – Equal Opportunity for Businesses and Lower Income Persons Located Within the Project Area**

(Applicable to Section 236 projects, where the estimated replacement cost of the project as determined by the Secretary of Housing and Urban Development exceeds \$500,000, and to all projects, including Section 236 regardless of estimated replacement cost, receiving rent supplement assistance under Title I, Section 101 of the Housing and Urban Development Act of 1965.)

**A.** The work to be performed under this contract is on a project assisted under a program providing direct Federal financial assistance from the Department of Housing and Urban Development and is subject to the requirements of Section 3 of the Housing and Urban Development Act of 1968, as amended, 12 U.S.C. 1701u. Section 3 requires that to the greatest extent feasible opportunities for training and employment be given lower income residents of the unit of local government or the metropolitan area (or nonmetropolitan county) as determined by the Secretary of Housing and Urban Development in which the projects located and contracts for work in connection with the project be awarded to business concerns which are located in, or owned in substantial part by persons residing in the same metropolitan area (or nonmetropolitan county) as the project.

### **Article 4 – Health and Safety**

**A.** No laborer or mechanic shall be required to work in surroundings or under working conditions which are unsanitary, hazardous, or dangerous to his health and safety as determined under construction safety and health standards promulgated by the Secretary of Labor by regulation.

**B.** The Contractor shall comply with all regulations issued by the Secretary of Labor pursuant to Title 29 Part 1926 (formerly part 1518) and failure to comply may result in imposition of sanctions pursuant to the Contract Work Hours and Safety Standards Act (Public Law 91-54, 83 Stat. 96).

**C.** The Contractor shall include the provisions of this Article in every subcontract so that such provisions will be binding on each subcontractor. The Contractor shall take such action with respect to any subcontract as the Secretary of Housing and Urban Development of the Secretary of Labor shall direct as a means of enforcing such provisions.

## Applicability

The Project or Program to which the construction work covered by this contract pertains is being assisted by the United States of America and the following Federal Labor Standards Provisions are included in this Contract pursuant to the provisions applicable to such Federal assistance.

**A. 1. (i) Minimum Wages.** All laborers and mechanics employed or working upon the site of the work, will be paid unconditionally and not less often than once a week, and without subsequent deduction or rebate on any account (except such payroll deductions as are permitted by regulations issued by the Secretary of Labor under the Copeland Act (29 CFR Part 3), the full amount of wages and bona fide fringe benefits (or cash equivalents thereof) due at time of payment computed at rates not less than those contained in the wage determination of the Secretary of Labor which is attached hereto and made a part hereof, regardless of any contractual relationship which may be alleged to exist between the contractor and such laborers and mechanics. Contributions made or costs reasonably anticipated for bona fide fringe benefits under Section I(b)(2) of the Davis-Bacon Act on behalf of laborers or mechanics are considered wages paid to such laborers or mechanics, subject to the provisions of 29 CFR 5.5(a)(1)(iv); also, regular contributions made or costs incurred for more than a weekly period (but not less often than quarterly) under plans, funds, or programs, which cover the particular weekly period, are deemed to be constructively made or incurred during such weekly period. Such laborers and mechanics shall be paid the appropriate wage rate and fringe benefits on the wage determination for the classification of work actually performed, without regard to skill, except as provided in 29 CFR 5.5(a)(4). Laborers or mechanics performing work in more than one classification may be compensated at the rate specified for each classification for the time actually worked therein: Provided, That the employer's payroll records accurately set forth the time spent in each classification in which work is performed. The wage determination (including any additional classification and wage rates conformed under 29 CFR 5.5(a)(1)(ii) and the Davis-Bacon poster (WH-1321) shall be posted at all times by the contractor and its subcontractors at the site of the work in a prominent and accessible, place where it can be easily seen by the workers.

**(ii) (a)** Any class of laborers or mechanics which is not listed in the wage determination and which is to be employed under the contract shall be classified in conformance with the wage determination. HUD shall approve an additional classification and wage rate and fringe benefits therefor only when the following criteria have been met:

**(1)** The work to be performed by the classification requested is not performed by a classification in the wage determination; and

**(2)** The classification is utilized in the area by the construction industry; and

**(3)** The proposed wage rate, including any bona fide fringe benefits, bears a reasonable relationship to the wage rates contained in the wage determination.

**(b)** If the contractor and the laborers and mechanics to be employed in the classification (if known), or their representatives, and HUD or its designee agree on the classification and wage rate (including the amount designated for fringe benefits where appropriate), a report of the action taken shall be sent by HUD or its designee to the Administrator of the Wage and Hour Division, Employment Standards Administration, U.S. Department of Labor, Washington, D.C. 20210. The Administrator, or an authorized representative, will approve, modify, or disapprove every additional classification action within 30 days of receipt and so advise HUD or its designee or will notify HUD or its designee within the 30-day period that additional time is necessary. (Approved by the Office of Management and Budget under OMB control number 1215-0140.)

**(c)** In the event the contractor, the laborers or mechanics to be employed in the classification or their representatives, and HUD or its designee do not agree on the proposed classification and wage rate (including the amount designated for fringe benefits, where appropriate), HUD or its designee shall refer the questions, including the views of all interested parties and the recommendation of HUD or its designee, to the Administrator for determination. The Administrator, or an authorized representative, will issue a determination within 30 days of receipt and so advise HUD or its designee or will notify HUD or its designee within the 30-day period that additional time is necessary. (Approved by the Office of Management and Budget under OMB Control Number 1215-0140.)

**(d)** The wage rate (including fringe benefits where appropriate) determined pursuant to subparagraphs (1)(ii)(b) or (c) of this paragraph, shall be paid to all workers performing work in the classification under this contract from the first day on which work is performed in the classification.

**(iii)** Whenever the minimum wage rate prescribed in the contract for a class of laborers or mechanics includes a fringe benefit which is not expressed as an hourly rate, the contractor shall either pay the benefit as stated in the wage determination or shall pay another bona fide fringe benefit or an hourly cash equivalent thereof.

**(iv)** If the contractor does not make payments to a trustee or other third person, the contractor may consider as part

of the wages of any laborer or mechanic the amount of any costs reasonably anticipated in providing bona fide fringe benefits under a plan or program, Provided, That the Secretary of Labor has found, upon the written request of the contractor, that the applicable standards of the Davis-Bacon Act have been met. The Secretary of Labor may require the contractor to set aside in a separate account assets for the meeting of obligations under the plan or program. (Approved by the Office of Management and Budget under OMB Control Number 1215-0140.)

**2. Withholding.** HUD or its designee shall upon its own action or upon written request of an authorized representative of the Department of Labor withhold or cause to be withheld from the contractor under this contract or any other Federal contract with the same prime contractor, or any other Federally-assisted contract subject to Davis-Bacon prevailing wage requirements, which is held by the same prime contractor so much of the accrued payments or advances as may be considered necessary to pay laborers and mechanics, including apprentices, trainees and helpers, employed by the contractor or any subcontractor the full amount of wages required by the contract. In the event of failure to pay any laborer or mechanic, including any apprentice, trainee or helper, employed or working on the site of the work, all or part of the wages required by the contract, HUD or its designee may, after written notice to the contractor, sponsor, applicant, or owner, take such action as may be necessary to cause the suspension of any further payment, advance, or guarantee of funds until such violations have ceased. HUD or its designee may, after written notice to the contractor, disburse such amounts withheld for and on account of the contractor or subcontractor to the respective employees to whom they are due. The Comptroller General shall make such disbursements in the case of direct Davis-Bacon Act contracts.

**3. (i) Payrolls and basic records.** Payrolls and basic records relating thereto shall be maintained by the contractor during the course of the work preserved for a period of three years thereafter for all laborers and mechanics working at the site of the work. Such records shall contain the name, address, and social security number of each such worker, his or her correct classification, hourly rates of wages paid (including rates of contributions or costs anticipated for bona fide fringe benefits or cash equivalents thereof of the types described in Section 1(b)(2)(B) of the Davis-bacon Act), daily and weekly number of hours worked, deductions made and actual wages paid. Whenever the Secretary of Labor has found under 29 CFR 5.5 (a)(1)(iv) that the wages of any laborer or mechanic include the amount of any costs reasonably anticipated in providing benefits under a plan or program described in Section 1(b)(2)(B) of the Davis-Bacon Act, the contractor shall maintain records which show that the commitment to provide such benefits is enforceable, that the plan or program is financially responsible, and that the plan or program has been

communicated in writing to the laborers or mechanics affected, and records which show the costs anticipated or the actual cost incurred in providing such benefits. Contractors employing apprentices or trainees under approved programs shall maintain written evidence of the registration of apprenticeship programs and certification of trainee programs, the registration of the apprentices and trainees, and the ratios and wage rates prescribed in the applicable programs. (Approved by the Office of Management and Budget under OMB Control Numbers 1215-0140 and 1215-0017.)

**(ii) (a)** The contractor shall submit weekly for each week in which any contract work is performed a copy of all payrolls to HUD or its designee if the agency is a party to the contract, but if the agency is not such a party, the contractor will submit the payrolls to the applicant sponsor, or owner, as the case may be, for transmission to HUD or its designee. The payrolls submitted shall set out accurately and completely all of the information required to be maintained under 29 CFR 5.5(a)(3)(i) except that full social security numbers and home addresses shall not be included on weekly transmittals. Instead the payrolls shall only need to include an individually identifying number for each employee (e.g., the last four digits of the employee's social security number). The required weekly payroll information may be submitted in any form desired. Optional Form WH-347 is available for this purpose from the Wage and Hour Division Web site at <http://www.dol.gov/esa/whd/forms/wh347instr.htm> or its successor site. The prime contractor is responsible for the submission of copies of payrolls by all subcontractors. Contractors and subcontractors shall maintain the full social security number and current address of each covered worker, and shall provide them upon request to HUD or its designee if the agency is a party to the contract, but if the agency is not such a party, the contractor will submit the payrolls to the applicant sponsor, or owner, as the case may be, for transmission to HUD or its designee, the contractor, or the Wage and Hour Division of the Department of Labor for purposes of an investigation or audit of compliance with prevailing wage requirements. It is not a violation of this subparagraph for a prime contractor to require a subcontractor to provide addresses and social security numbers to the prime contractor for its own records, without weekly submission to HUD or its designee. (Approved by the Office of Management and Budget under OMB Control Number 1215-0149.)

**(b)** Each payroll submitted shall be accompanied by a "Statement of Compliance," signed by the contractor or subcontractor or his or her agent who pays or supervises the payment of the persons employed under the contract and shall certify the following:

**(1)** That the payroll for the payroll period contains the information required to be provided under 29 CFR 5.5 (a)(3)(ii), the appropriate information is being maintained under 29 CFR 5.5(a)(3)(i), and that such information is correct and complete;

(2) That each laborer or mechanic (including each helper, apprentice, and trainee) employed on the contract during the payroll period has been paid the full weekly wages earned, without rebate, either directly or indirectly, and that no deductions have been made either directly or indirectly from the full wages earned, other than permissible deductions as set forth in 29 CFR Part 3;

(3) That each laborer or mechanic has been paid not less than the applicable wage rates and fringe benefits or cash equivalents for the classification of work performed, as specified in the applicable wage determination incorporated into the contract.

(c) The weekly submission of a properly executed certification set forth on the reverse side of Optional Form WH-347 shall satisfy the requirement for submission of the "Statement of Compliance" required by subparagraph A.3.(ii)(b).

(d) The falsification of any of the above certifications may subject the contractor or subcontractor to civil or criminal prosecution under Section 1001 of Title 18 and Section 231 of Title 31 of the United States Code.

(iii) The contractor or subcontractor shall make the records required under subparagraph A.3.(i) available for inspection, copying, or transcription by authorized representatives of HUD or its designee or the Department of Labor, and shall permit such representatives to interview employees during working hours on the job. If the contractor or subcontractor fails to submit the required records or to make them available, HUD or its designee may, after written notice to the contractor, sponsor, applicant or owner, take such action as may be necessary to cause the suspension of any further payment, advance, or guarantee of funds. Furthermore, failure to submit the required records upon request or to make such records available may be grounds for debarment action pursuant to 29 CFR 5.12.

#### 4. Apprentices and Trainees.

(i) **Apprentices.** Apprentices will be permitted to work at less than the predetermined rate for the work they performed when they are employed pursuant to and individually registered in a bona fide apprenticeship program registered with the U.S. Department of Labor, Employment and Training Administration, Office of Apprenticeship Training, Employer and Labor Services, or with a State Apprenticeship Agency recognized by the Office, or if a person is employed in his or her first 90 days of probationary employment as an apprentice in such an apprenticeship program, who is not individually registered in the program, but who has been certified by the Office of Apprenticeship Training, Employer and Labor Services or a State Apprenticeship Agency (where appropriate) to be eligible for probationary employment as an apprentice. The allowable ratio of apprentices to journeymen on the job site in any craft classification shall not be greater than the ratio permitted to the contractor as to the entire work force under the registered program. Any worker listed on a payroll at an apprentice wage rate, who

is not registered or otherwise employed as stated above, shall be paid not less than the applicable wage rate on the wage determination for the classification of work actually performed. In addition, any apprentice performing work on the job site in excess of the ratio permitted under the registered program shall be paid not less than the applicable wage rate on the wage determination for the work actually performed. Where a contractor is performing construction on a project in a locality other than that in which its program is registered, the ratios and wage rates (expressed in percentages of the journeyman's hourly rate) specified in the contractor's or subcontractor's registered program shall be observed. Every apprentice must be paid at not less than the rate specified in the registered program for the apprentice's level of progress, expressed as a percentage of the journeymen hourly rate specified in the applicable wage determination. Apprentices shall be paid fringe benefits in accordance with the provisions of the apprenticeship program. If the apprenticeship program does not specify fringe benefits, apprentices must be paid the full amount of fringe benefits listed on the wage determination for the applicable classification. If the Administrator determines that a different practice prevails for the applicable apprentice classification, fringes shall be paid in accordance with that determination. In the event the Office of Apprenticeship Training, Employer and Labor Services, or a State Apprenticeship Agency recognized by the Office, withdraws approval of an apprenticeship program, the contractor will no longer be permitted to utilize apprentices at less than the applicable predetermined rate for the work performed until an acceptable program is approved.

(ii) **Trainees.** Except as provided in 29 CFR 5.16, trainees will not be permitted to work at less than the predetermined rate for the work performed unless they are employed pursuant to and individually registered in a program which has received prior approval, evidenced by formal certification by the U.S. Department of Labor, Employment and Training Administration. The ratio of trainees to journeymen on the job site shall not be greater than permitted under the plan approved by the Employment and Training Administration. Every trainee must be paid at not less than the rate specified in the approved program for the trainee's level of progress, expressed as a percentage of the journeyman hourly rate specified in the applicable wage determination. Trainees shall be paid fringe benefits in accordance with the provisions of the trainee program. If the trainee program does not mention fringe benefits, trainees shall be paid the full amount of fringe benefits listed on the wage determination unless the Administrator of the Wage and Hour Division determines that there is an apprenticeship program associated with the corresponding journeyman wage rate on the wage determination which provides for less than full fringe benefits for apprentices. Any employee listed on the payroll at a trainee rate who is not registered and participating in a training plan approved by

the Employment and Training Administration shall be paid not less than the applicable wage rate on the wage determination for the work actually performed. In addition, any trainee performing work on the job site in excess of the ratio permitted under the registered program shall be paid not less than the applicable wage rate on the wage determination for the work actually performed. In the event the Employment and Training Administration withdraws approval of a training program, the contractor will no longer be permitted to utilize trainees at less than the applicable predetermined rate for the work performed until an acceptable program is approved.

**(iii) Equal employment opportunity.** The utilization of apprentices, trainees and journeymen under 29 CFR Part 5 shall be in conformity with the equal employment opportunity requirements of Executive Order 11246, as amended, and 29 CFR Part 30.

**5. Compliance with Copeland Act requirements.** The contractor shall comply with the requirements of 29 CFR Part 3 which are incorporated by reference in this contract

**6. Subcontracts.** The contractor or subcontractor will insert in any subcontracts the clauses contained in subparagraphs 1 through 11 in this paragraph A and such other clauses as HUD or its designee may by appropriate instructions require, and a copy of the applicable prevailing wage decision, and also a clause requiring the subcontractors to include these clauses in any lower tier subcontracts. The prime contractor shall be responsible for the compliance by any subcontractor or lower tier subcontractor with all the contract clauses in this paragraph.

**7. Contract termination; debarment.** A breach of the contract clauses in 29 CFR 5.5 may be grounds for termination of the contract and for debarment as a contractor and a subcontractor as provided in 29 CFR 5.12.

**8. Compliance with Davis-Bacon and Related Act Requirements.** All rulings and interpretations of the Davis-Bacon and Related Acts contained in 29 CFR Parts 1, 3, and 5 are herein incorporated by reference in this contract

**9. Disputes concerning labor standards.** Disputes arising out of the labor standards provisions of this contract shall not be subject to the general disputes clause of this contract. Such disputes shall be resolved in accordance with the procedures of the Department of Labor set forth in 29 CFR Parts 5, 6, and 7. Disputes within the meaning of this clause include disputes between the contractor (or any of its subcontractors) and HUD or its designee, the U.S. Department of Labor, or the employees or their representatives.

**10. (i) Certification of Eligibility.** By entering into this contract the contractor certifies that neither it (nor he or she) nor any person or firm who has an interest in the contractor's firm is a person or firm ineligible to be awarded Government contracts by virtue of Section 3(a) of the Davis-Bacon Act or 29 CFR 5.12(a)(1) or to be

awarded HUD contracts or participate in HUD programs pursuant to 24 CFR Part 24.

**(ii)** No part of this contract shall be subcontracted to any person or firm ineligible for award of a Government contract by virtue of Section 3(a) of the Davis-Bacon Act or 29 CFR 5.12(a)(1) or to be awarded HUD contracts or participate in HUD programs pursuant to 24 CFR Part 24.

**(iii)** The penalty for making false statements is prescribed in the U.S. Criminal Code, 18 U.S.C. 1001. Additionally, U.S. Criminal Code, Section 1 01 0, Title 18, U.S.C., "Federal Housing Administration transactions", provides in part: "Whoever, for the purpose of . . . influencing in any way the action of such Administration..... makes, utters or publishes any statement knowing the same to be false..... shall be fined not more than \$5,000 or imprisoned not more than two years, or both."

**11. Complaints, Proceedings, or Testimony by Employees.** No laborer or mechanic to whom the wage, salary, or other labor standards provisions of this Contract are applicable shall be discharged or in any other manner discriminated against by the Contractor or any subcontractor because such employee has filed any complaint or instituted or caused to be instituted any proceeding or has testified or is about to testify in any proceeding under or relating to the labor standards applicable under this Contract to his employer.

**B. Contract Work Hours and Safety Standards Act.** The provisions of this paragraph B are applicable where the amount of the prime contract exceeds \$100,000. As used in this paragraph, the terms "laborers" and "mechanics" include watchmen and guards.

**(1) Overtime requirements.** No contractor or subcontractor contracting for any part of the contract work which may require or involve the employment of laborers or mechanics shall require or permit any such laborer or mechanic in any workweek in which the individual is employed on such work to work in excess of 40 hours in such workweek unless such laborer or mechanic receives compensation at a rate not less than one and one-half times the basic rate of pay for all hours worked in excess of 40 hours in such workweek.

**(2) Violation; liability for unpaid wages; liquidated damages.** In the event of any violation of the clause set forth in subparagraph (1) of this paragraph, the contractor and any subcontractor responsible therefor shall be liable for the unpaid wages. In addition, such contractor and subcontractor shall be liable to the United States (in the case of work done under contract for the District of Columbia or a territory, to such District or to such territory), for liquidated damages. Such liquidated damages shall be computed with respect to each individual laborer or mechanic, including watchmen and guards, employed in violation of the clause set forth in subparagraph (1) of this paragraph, in the sum of \$10 for each calendar day on which such individual was required or permitted to work in excess of the standard workweek of 40 hours without payment of the overtime wages required by the clause set forth in subparagraph (1) of this paragraph.

---

**(3) Withholding for unpaid wages and liquidated damages.** HUD or its designee shall upon its own action or upon written request of an authorized representative of the Department of Labor withhold or cause to be withheld, from any moneys payable on account of work performed by the contractor or subcontractor under any such contract or any other Federal contract with the same prime contract, or any other Federally-assisted contract subject to the Contract Work Hours and Safety Standards Act which is held by the same prime contractor such sums as may be determined to be necessary to satisfy any liabilities of such contractor or subcontractor for unpaid wages and liquidated damages as provided in the clause set forth in subparagraph (2) of this paragraph.

**(4) Subcontracts.** The contractor or subcontractor shall insert in any subcontracts the clauses set forth in subparagraph (1) through (4) of this paragraph and also a clause requiring the subcontractors to include these clauses in any lower tier subcontracts. The prime contractor shall be responsible for compliance by any subcontractor or lower tier subcontractor with the clauses set forth in subparagraphs (1) through (4) of this paragraph.

**C. Health and Safety.** The provisions of this paragraph C are applicable where the amount of the prime contract exceeds \$100,000.

**(1)** No laborer or mechanic shall be required to work in surroundings or under working conditions which are unsanitary, hazardous, or dangerous to his health and safety as determined under construction safety and health standards promulgated by the Secretary of Labor by regulation.

**(2)** The Contractor shall comply with all regulations issued by the Secretary of Labor pursuant to Title 29 Part 1926 and failure to comply may result in imposition of sanctions pursuant to the Contract Work Hours and Safety Standards Act, (Public Law 91-54, 83 Stat 96). 40 USC 3701 et seq.

**(3)** The contractor shall include the provisions of this paragraph in every subcontract so that such provisions will be binding on each subcontractor. The contractor shall take such action with respect to any subcontractor as the Secretary of Housing and Urban Development or the Secretary of Labor shall direct as a means of enforcing such provisions.

# Schedule of Amounts for Contract Payments

U.S. Department of Housing and Urban Development  
Office of Public and Indian Housing

OMB Approval No. 2577-0157  
(Exp. 1/31/2027)

No progress payments shall be made to the contractor unless a schedule of amounts for contract payments in accordance with the construction contract is received.

Public reporting burden for this collection of information is estimated to average 1 hour per response, including the time for reviewing instructions, searching existing data sources, gathering and maintaining the data needed, and completing and reviewing the collection of information. HUD may not conduct or sponsor, and an applicant is not required to respond to a collection of information unless it displays a currently valid OMB control number. Comments regarding the accuracy of this burden estimate and any suggestions for reducing this burden can be sent to the Reports Management Officer, Office of Policy Development and Research, REE, Department of Housing and Urban Development, 451 7th St SW, Room 4176, Washington, DC 20410-5000. When providing comments, please refer to OMB Approval No. 2577-0157. Construction practices and HUD administrative requirements establish the need that HAs maintain certain records or submit certain documents in conjunction with the oversight of the award of construction contracts for the construction of new low-income housing developments or modernization of existing developments. These forms are used by HAs to provide information on the construction progress schedule and schedule of amounts for contract payments. Responses to the collection of information are required to obtain a benefit or to retain a benefit. The information requested does not lend itself to confidentiality.

Project Name and Location	Project Number
---------------------------	----------------

Name, Address, and Zip Code of Contractor
---

Nature of Contract	Contract Number
--------------------	-----------------

Approved for Contractor by	Title	Date (mm/dd/yyyy)
----------------------------	-------	-------------------

Approved for Architect by	Title	Date (mm/dd/yyyy)
---------------------------	-------	-------------------

Approved for Owner by	Title	Date (mm/dd/yyyy)
-----------------------	-------	-------------------

Item No. (1)	Description of Item (2)	Quantity (3)	Unit of Measure (4)	Unit Price in Place (5)	Amount of Sub-Item (6)	Amount of Principal Item (7)

<b>Total Amount of Contract or Carried Forward</b>	\$
--	----

To the best of my knowledge, all the information stated herein, as well as any information provided in the accompaniment herewith, is true and accurate.  
**Warning:** HUD will prosecute false claims and statements. Conviction may result in criminal and/or civil penalties. (18 U.S.C. 1001, 1010, 1012; 31 U.S.C. 3729, 3802)

Signature of authorized representative	Date signed (mm/dd/yyyy)
--	--------------------------

## Instructions for Preparation of form HUD-51000

1. A separate breakdown is required for each project and prime contract instructions for preparation are given below.
  - a. **Heading.** Enter all identifying information required for both forms.
  - b. **Columns 1 and 2.** In column 1, enter the item numbers starting with No. 1, and in column 2 enter each principal division of work incorporated in the contract work.
    - (1) **Master List.** The Master list contains the basic items into which any construction contract may be subdivided for the purpose of preparing the Construction Progress Schedule and the Periodical Estimates for Partial Payments. Only those items shall be selected which apply to the particular contract. To ensure uniformity, no change shall be made in the item numbers. Generally, about 25 to 40 major items appear in a contract.
    - (2) **Items Subdivided.** In the Contractor's breakdown, against which all periodical estimates will be checked prior to payment, each major item must be subdivided into sub-items pertinent to the project involved and in agreement with the Contractor's intended basis for requesting monthly payments.
  - c. **Column 3.** Enter the total quantity for each sub-item of each principal division of work listed in the breakdown.
  - d. **Column 4.** Enter the appropriate unit of measure for each sub-item of work opposite the quantities described in column 3, such as "sq. ft.," "cu. yd.," "tons," "lb.," "lumber per M/BM," "brickwork per M," etc., applicable to the particular sub-item. Items shown on "lump sum" or equivalent basis will be paid for only on completion of the whole item and not on a percentage of completion basis.
  - e. **Column 5.** Enter the unit price, in place, of each sub-item of work.
  - f. **Column 6.** Enter the amount of each sub-item obtained by multiplying the quantities in column 3 by the corresponding unit prices in column 5.
  - g. **Column 7.** Enter the amount of principal item only, obtained by adding the amounts of all sub-items of each principal division of work listed in column 6. Continue with the breakdown on form HUD-51000.
  - h. The "Schedule of Amounts for Contract Payments" shall be signed and dated in the space provided at the bottom of each sheet of the form by the individual who prepared the breakdown for the Contractor.
2. The minimum number of copies required for each submission for approval is an original and two copies. When approved, one fully approved copy will be returned to the Contractor.

### Master List of Items

Item No.	Division of Work	Item No.	Division of Work	Item No.	Division of Work
1	Bond	20	Rough Carpentry		
2	General Conditions	21	Metal Bucks	44	<b>Site Improvements</b> Retaining Walls
3	Demolition & Clearing	22	Caulking	45	Storm Sewers
	<b>Structures</b>	23	Weatherstripping	46	Sanitary Sewers
4	General Excavation	24	Lath & Plastering-Drywall	47	Water Distribution System
5	Footing Excavation	25	Stucco	48	Gas Distribution System
6	Backfill	26	Finish Carpentry	49	Electrical Distribution System
7	Foundation Piles & Caissons	27	Finish Hardware	50	Street & Yard Lighting
8	Concrete Foundations	28	Glass & Glazing	51	Fire & Police Alarm System
9	Concrete Superstructures	29	Metal Doors	52	Fire Protection System
10	Reinforcing Steel	30	Metal Base & Trim	53	Street Work
11	Waterproofing & Dampproofing	31	Toilet Partitions	54	Yard Work
12	Spandrel Waterproofing	32	Floors	55	(Other)
13	Structural Steel	33	Painting & Decorating	56	(Other)
14	Masonry	34	Screens		
15	Stonework	35	Plumbing		<b>Equipment</b>
16	Miscellaneous & Ornamental Metal	36	Heating	57	Shades & Drapery Rods
17	Metal Windows	37	Ventilating System	58	Ranges
18	Roofing	38	Electrical	59	Refrigerators
19	Sheet Metal	39	Elevators	60	Kitchen Cabinets & Work Tables
		40	Elevator Enclosures—Metal	61	Laundry Equipment
		41	Incinerators—Masonry & Parts	62	(Other)
		42	(Other)		
		43	(Other)	63	<b>Punch List</b> <sup>1</sup> / <sub>2</sub>
				64	Lawns & Planting

1 General Conditions should be 3% to 5% of contract amount.

2 Punch List should be approximately 1/2 of 1% or \$30 per dwelling unit, whichever is greater.

# Periodic Estimate for Partial Payment

**U.S. Department of Housing  
and Urban Development**  
Office of Public and Indian Housing

OMB Approval No. 2577-015  
7 (exp. 1/31/2027)

Submit original and one copy to the Public Housing Agency.  
Complete instructions are on the back of this form.

Public reporting burden for this collection of information is estimated to average 3.5 hours per response, including the time for reviewing instructions, searching existing data sources, gathering and maintaining the data needed, and completing and reviewing the collection of information. HUD may not conduct or sponsor, and an applicant is not required to respond to a collection of information unless it displays a currently valid OMB control number. Comments regarding the accuracy of this burden estimate and any suggestions for reducing this burden can be sent to the Reports Management Officer, Office of Policy Development and Research, REE, Department of Housing and Urban Development, 451 7th St SW, Room 4176, Washington, DC 20410-5000. When providing comments, please refer to OMB Approval No. 2577-0157. This information is collected under the authority of Section 6(c) of the U.S Housing Act of 1937 and HUD regulations. HAs are responsible for contract administration to ensure that the work for project development is done in accordance with State laws and HUD requirements. The contractor/subcontractor reports provide details and summaries on payments, change orders, and schedule of materials stored for the project. The information will be used to ensure that the total development costs, identified in the ACC, are kept as low as possible and consistent with HUD construction requirements. Responses to the collection are necessary to obtain a benefit. The information requested does not lend itself to confidentiality.

Name of Public Housing Agency	Periodic Estimate Number	Period From (mm/dd/yyyy) To (mm/dd/yyyy)
-------------------------------	--------------------------	---

Location of Project	Project Number
---------------------	----------------

Name of Contractor	Contract Number
--------------------	-----------------

Item Number (1)	Description of Item (2)	Completed to Date (3)
		\$

<b>Value of Contract Work Completed to Date (Transfer this total to line 5 on back of this sheet)</b>	<b>\$</b>
---	-----------

**Instructions**

**Headings.** Enter all identifying data required. Periodic estimates must be numbered in sequence beginning with the number 1.

**Columns 1 and 2.** The "Item Number" and "Description of Item" must correspond to the number and descriptive title assigned to each principal division of work in the "Schedule of Amounts for Contract Payments", form HUD-51000.

**Column 3.** Enter the accumulated value of each principal division of work completed as of the closing date of the periodic estimate. Enter the total in the space provided.

**Certifications.** The certification of the contractor includes the analysis of amounts used to determine the net balance due. In the first paragraph, enter the name of the Public Housing Agency, the contractor, and the date of the contract. Enter the calculations used in arriving at the "Balance Due This Payment" on lines 1 through 16.

Enter the contractor's name and signature in the certification following line 16.

The latter portion of this certification relating to payment of legal rates of wages, is required by the contract before any payment may be made. However, if the contractor does not choose to certify on behalf of his/her subcontractors to wage payments made by them, he/she may modify the language to cover only himself /herself and attach a list of all subcontractors who employed labor on the site during the period covered by the Periodic Estimate, together with the individual certifications of each.

**Certification of the Contractor or Duly Authorized Representative**

According to the best of my knowledge and belief, I certify that all items and amounts shown on the other side of this form are correct; that all work has been performed and material supplied in full accordance with the items and conditions of the contract between the (name of owner)

\_\_\_\_\_ and (contractor) \_\_\_\_\_

dated (mm/dd/yyyy) \_\_\_\_\_, and duly authorized deviations, substitutions, alterations, and additions; that the following is a true and correct statement of the Contract Account up to and including the last day of the period covered by this estimate, and that no part of the "Balance Due This Payment" has been received.

1. Original Contract Amount \$ \_\_\_\_\_

**Approved Change Orders:**

2. Additions (Total from Col. 3, form HUD-51002) \$ \_\_\_\_\_  
3. Deductions (Total from Col. 5, form HUD-51002) \$ \_\_\_\_\_ (net) \$ \_\_\_\_\_  
4. Current Adjusted Contract Amount (line 1 plus or minus net) \$ \_\_\_\_\_

**Computation of Balance Due this Payment**

5. Value of Original Contract work completed to date (from other side of this form) \$ \_\_\_\_\_

**Completed Under Approved Change Orders**

6. Additions (from Col. 4, form HUD-51002) \$ \_\_\_\_\_  
7. Deductions (from Col.5, form HUD-51002) \$ \_\_\_\_\_ (net) \$ \_\_\_\_\_  
8. Total Value of Work in Place (line 5 plus or minus net line 7) \$ \_\_\_\_\_  
9. **Less:** Retainage, \_\_\_\_\_ % \$ \_\_\_\_\_  
10. Net amount earned to date (line 8 less line 9) \$ \_\_\_\_\_  
11. **Less:** Previously earned (line 10, last Periodic Estimate) \$ \_\_\_\_\_  
12. Net amount due, work in place (line 10 less line 11) \$ \_\_\_\_\_

**Value of Materials Properly Stored**

13. At close of this period (from form HUD-51004) \$ \_\_\_\_\_  
14. **Less:** Allowed last period \$ \_\_\_\_\_  
15. Increase (decrease) from amount allowed last period \$ \_\_\_\_\_  
16. **Balance Due This Payment** \$ \_\_\_\_\_

I further certify that all just and lawful bills against the undersigned and his/her subcontractors for labor, material, and equipment employed in the performance of this contract have been paid in full in accordance with the terms and conditions of this contract, and that the undersigned and his/her subcontractors have complied with, or that there is an honest dispute with respect to, the labor provisions of this contract.

Name of Contractor \_\_\_\_\_ Signature of Authorized Representative \_\_\_\_\_ Title \_\_\_\_\_ Date (mm/dd/yyyy) \_\_\_\_\_

**Certificate of Authorized Project Representative and of Contracting Officer**

Each of us certifies that he/she has checked and verified this Periodic Estimate No. \_\_\_\_\_; that to the best of his/her knowledge and belief it is a true statement of the value of work performed and material supplied by the contractor; that all work and material included in this estimate has been inspected by him/her or by his/her authorized assistants; and that such work has been performed or supplied in full accordance with the drawings and specifications, all applicable accessibility requirements (including Section 504 and Title II of the Americans with Disabilities Act; and the Fair Housing Act and Title III of the Americans with Disabilities Act, if applicable), the terms and conditions of the contract, and duly authorized deviations, substitutions, alterations, and additions, all of which have been duly approved.

We, therefore, approve as the "Balance Due this Payment" the amount of \$ \_\_\_\_\_

Authorized Project Representative \_\_\_\_\_ Date (mm/dd/yyyy) \_\_\_\_\_ Contracting Officer \_\_\_\_\_ Date (mm/dd/yyyy) \_\_\_\_\_

I certify the information on this form and in any accompanying documentation is true and accurate. I acknowledge making, presenting, or submitting a false, fictitious, or fraudulent statement, representation, or certification may result in criminal, civil, and/or administrative sanctions, including fines, penalties, and confinement for up to 5 years, (18 U.S.C. §§ 287, 1001 and 31 U.S.C. §3729)

# Schedule of Change Orders

**U.S. Department of Housing and Urban Development**  
Office of Public and Indian Housing

OMB Approval No. 2577-0157  
(exp. 1/31/2027)

Public reporting burden for this collection of information is estimated to average 1 hour per response, including the time for reviewing instructions, searching existing data sources, gathering and maintaining the data needed, and completing and reviewing the collection of information. HUD may not conduct or sponsor, and an applicant is not required to respond to a collection of information unless it displays a currently valid OMB control number. Comments regarding the accuracy of this burden estimate and any suggestions for reducing this burden can be sent to the Reports Management Officer, Office of Policy Development and Research, REE, Department of Housing and Urban Development, 451 7th St SW, Room 4176, Washington, DC 20410-5000. When providing comments, please refer to OMB Approval No. 2577-0157. This information is collected under the authority of Section 6(c) of the U.S Housing Act of 1937 and HUD regulations. HAs are responsible for contract administration to ensure that the work for project development is done in accordance with State laws and HUD requirements. The contractor/subcontractor reports provide details and summaries on payments, change orders, and schedule of materials stored for the project. The information will be used to ensure that the total development costs, identified in the ACC, are kept as low as possible and consistent with HUD construction requirements. Responses to the collection are necessary to obtain a benefit. The information requested does not lend itself to confidentiality.

**Instructions:** Contractors use this form for reporting the details of approved Change Orders. Attach an original (or a copy) to each copy of the Periodic Estimate for Partial Payment (form HUD-51001) submission, and send to the Public Housing Agency. Complete all entries. Only Change Orders which bear the signatures required by the contract are to be recorded.

Name of Public Housing Agency	Supporting Periodic Estimate for Partial Payment Number	Period From (mm/dd/yyyy) to (mm/dd/yyyy)
-------------------------------	---	--

Location of Project	Project Number
---------------------	----------------

Name of Contractor	Contract Number
--------------------	-----------------

Approved Change Orders		Additions		Deductions
Change Order Number (1)	Dated (mm/dd/yyyy) (2)	Total Amount of Change Order (3)	Value of Work Completed to Date (4)	Total Amount of Change Order (5)
		\$	\$	\$
<b>Totals</b>		\$	\$	\$

Authorized Project Representative	Date (mm/dd/yyyy)
-----------------------------------	-------------------

I certify that the information provided on this form and in any accompanying documentation is true and accurate. I acknowledge that making, presenting, or submitting a false, fictitious, or fraudulent statement, representation, or certification may result in criminal, civil, and/or administrative sanctions, including fines, civil penalties, and confinement for up to 5 years. (18 U.S.C. §§ 287, 1001 and 31 U.S.C. §3729)

# Schedule of Materials Stored

U.S. Department of Housing  
and Urban Development  
Office of Public and Indian Housing

OMB Approval No. 2577-0157  
(exp. 1/301/2027)

Public reporting burden for this collection of information is estimated to average 1.5 hours per response, including the time for reviewing instructions, searching existing data sources, gathering and maintaining the data needed, and completing and reviewing the collection of information. HUD may not conduct or sponsor, and an applicant is not required to respond to a collection of information unless it displays a currently valid OMB control number. Comments regarding the accuracy of this burden estimate and any suggestions for reducing this burden can be sent to the Reports Management Officer, Office of Policy Development and Research, REE, Department of Housing and Urban Development, 451 7th St SW, Room 4176, Washington, DC 20410-5000. When providing comments, please refer to OMB Approval No. 2577-0157. This information is collected under the authority of Section 6(c) of the U.S. Housing Act of 1937 and HUD regulations. HAs are responsible for contract administration to ensure that the work for project development is done in accordance with State laws and HUD requirements. The contractor/subcontractor reports provide details and summaries on payments, change orders, and schedule of materials stored for the project. The information will be used to ensure that the total development costs, identified in the ACC, are kept as low as possible and consistent with HUD construction requirements. Responses to the collection are necessary to obtain a benefit. The information requested does not lend itself to confidentiality.

**Instructions:** This form is to be used to support the Periodic Estimate for Partial Payment (form HUD-51001). The contractor must prepare a separate schedule for his/her materials and for those of his/her subcontractors. Attach an original (or a copy ) to each copy of the Summary of Materials Stored (form HUD-51004). Enter all identifying data and list materials stored. The listing of materials stored must correspond to the arrangement established on the Schedule of Contract Payments (form HUD-51000) and each item will be keyed by corresponding item number. This form must be signed as noted.

Name of Public Housing Agency	Supporting Periodic Estimate for Partial Payment Number	Period From (mm/dd/yyyy) To (mm/dd/yyyy)
-------------------------------	---	---

Name and Location of Project	Project Number
------------------------------	----------------

Name of General Contractor	Contract Number
----------------------------	-----------------

Name of Subcontractor	Subcontract Number
-----------------------	--------------------

Item Number*	Description and Quality	Quantity	Unit of Measure	Unit Price at Site	Total Price
--------------	-------------------------	----------	-----------------	--------------------	-------------

<b>Amount Carried Forward</b>	<b>\$</b>
-------------------------------	-----------

Item Number*	Description and Quality	Quantity	Unit of Measure	Unit Price at Site	Total Price

<b>Total Amount or Amount Carried Forward</b>	<b>\$</b>
---	-----------

Prepared by (Contractor's Representative)	Date (mm/dd/yyyy)	Checked by (Owner's Representative)	Date (mm/dd/yyyy)
---	-------------------	-------------------------------------	-------------------

I certify that the information provided on this form and in any accompanying documentation is true and accurate. I acknowledge that making, presenting, or submitting a false, fictitious, or fraudulent statement, representation, or certification may result in criminal, civil, and/or administrative sanctions, including fines, penalties, and imprisonment.

As identified in Schedule of Amounts for Contract Payments, form HUD-51000.

Previous Editions are Obsolete

form HUD-51003 (1/2014)

# Summary of Materials Stored

U.S. Department of Housing  
and Urban Development  
Office of Public and Indian Housing

OMB Approval No. 2577-0157  
(exp. 1/31/2027)

Public reporting burden for this collection of information is estimated to average 2.5 hours per response, including the time for reviewing instructions, searching existing data sources, gathering and maintaining the data needed, and completing and reviewing the collection of information. HUD may not conduct or sponsor, and an applicant is not required to respond to a collection of information unless it displays a currently valid OMB control number. Comments regarding the accuracy of this burden estimate and any suggestions for reducing this burden can be sent to the Reports Management Officer, Office of Policy Development and Research, REE, Department of Housing and Urban Development, 451 7th St SW, Room 4176, Washington, DC 20410-5000. When providing comments, please refer to OMB Approval No. 2577-0157. This information is collected under the authority of Section 6(c) of the U.S Housing Act of 1937 and HUD regulations. HAs are responsible for contract administration to ensure that the work for project development is done in accordance with State laws and HUD requirements. The contractor/subcontractor reports provide details and summaries on payments, change orders, and schedule of materials stored for the project. The information will be used to ensure that the total development costs, identified in the ACC, are kept as low as possible and consistent with HUD construction requirements. Responses to the collection are necessary to obtain a benefit. The information requested does not lend itself to confidentiality.

**Instructions:** This form is for the Contractor to summarize the value of materials stored at the site (as shown on the schedule, form HUD-51003). Use a separate line for the contractor and each of his/her subcontractors. Prepare an original and one copy, attach form HUD-51003, and send to the Public Housing Agency with the Periodic Estimate for Partial Payment, form HUD-51001. **Payment Value.** No more than 90 percent of the estimated value of the stored materials will be allowed, and only the net amount will be carried to line 13 on the back of the Periodic Estimate for Partial Payment, form HUD-51001. **Signatures.** This form must be signed by those employees of the contractor and of the Public Housing Agency who prepare and check the Schedule of Materials Stored, form HUD-51003.

Name of Public Housing Agency	Supporting Periodic Estimate for Partial Payment Number	Period From (mm/dd/yyyy)	To (mm/dd/yyyy)
-------------------------------	---	--------------------------	-----------------

Location of Project	Project Number
---------------------	----------------

Name of General Contractor	Contract Number
----------------------------	-----------------

Name of General Contractor or Subcontractor	Amounts
General Contractor	\$

Subcontractors	\$
----------------	----

	<b>Total</b>	\$
	<b>Less 10%</b>	\$
	<b>Net</b>	\$

Prepared by	Date (mm/dd/yyyy)	Checked by	Date (mm/dd/yyyy)
-------------	-------------------	------------	-------------------

I certify that I or my authorized representatives have examined and checked in detail the invoices representing the cost of materials set forth in appended "Schedule of Materials Stored", form HUD-51003, dated (mm/dd/yyyy) \_\_\_\_\_ submitted by \_\_\_\_\_ consisting of \_\_\_\_\_ sheets with an indicated cost of \$ \_\_\_\_\_, and find that the net unit prices set forth in the schedule are the same or less than the invoices examined, and that such materials were suitably stored at the site of the development as of (date)(mm/dd/yyyy) \_\_\_\_\_.

Name of Owner	By (Authorized Representative)	Title	Date (mm/dd/yyyy)
---------------	--------------------------------	-------	-------------------

**Warning:** HUD will prosecute false claims and statements. Conviction may result in criminal and/or civil penalties. (18 U.S.C. 1001, 1010, 1012; 31 U.S.C. 3729, 3802)

form HUD-51004 (01/2011)

# Construction Progress Schedule

U.S. Department of Housing and Urban Development  
Office of Public and Indian Housing

OMB Approval No. 2577-0157 (Exp. 1/31/2027)

Public reporting burden for this collection of information is estimated to average 1 hour per response, including the time for reviewing instructions, searching existing data sources, gathering and maintaining the data needed, and completing and reviewing the collection of information. HUD may not conduct or sponsor, and an applicant is not required to respond to a collection of information unless it displays a currently valid OMB control number. Comments regarding the accuracy of this burden estimate and any suggestions for reducing this burden can be sent to the Reports Management Officer, Office of Policy Development and Research, REE, Department of Housing and Urban Development, 451 7th St SW, Room 4176, Washington, DC 20410-5000. When providing comments, please refer to OMB Approval No. 2577-0157. Construction practices and HUD administrative requirements establish the need that HAs maintain certain records or submit certain documents in conjunction with the oversight of the award of construction contracts for the construction of new low-income housing developments or modernization of existing developments. These forms are used by HAs to provide information on the construction progress schedule and schedule of amounts for contract payments. Responses to the collection of information are required to obtain a benefit or to retain a benefit. The information requested does not lend itself to confidentiality.

1. Name of Public Housing Agency/Indian Housing Authority (PHA/IHA)		
2. City	3. State	5. Project Name
4. Location		6. Project Number
7. Contract For		8. Contract Time (Days)
9. From (mm/dd/yyyy) To (mm/dd/yyyy)		10. Contract Price \$
11. Number of Buildings	12. Number of Dwelling Units	13. Number of Rooms

(Submit as many pages as necessary to cover the construction period.)	Year (yyy)	Month					
Actual Monthly Value, Work in Place	(\$)						
Actual Accumulated Progress	(%)						
Anticipated Monthly Value	(\$)						
Accumulated Scheduled Progress	(%)						

Submitted by	Contractor's Name		
	Title	Signature	Date (mm/dd/yyyy)
Approved by	PHA/IHA		
	Title		Date (mm/dd/yyyy)
Approved by	Architect		Date (mm/dd/yyyy)

**Instructions for Preparation of Construction Progress Schedule  
Form HUD-5372**

**General.** The information required for items 1 through 6 can be obtained from the contract documents. (7.) Enter the type of work awarded by the PHA/IHA. This may be "general construction," "plumbing," "heating," "electrical," etc., depending upon prime contract awards. (8.) Enter the contract time in calendar days (unless otherwise stated). (9.) Enter the starting and completion dates as established by the Notice to Proceed.

**Year and Month.** At the top of the Schedule, space is provided for inserting the "Year" and "Month" to identify the times during which the work is to be performed.

**Year.** Enter the year when the Notice to Proceed was issued. If the starting date of the contract is such that the time assigned for completion will be carried into a succeeding year, two yearly designations will be shown, each centered over the applicable spread of time for each year.

**Month.** The body of the Schedule is divided into Columns, each representing a period of one month. Starting in the Column with the month stated in the Notice to Proceed, enter at the top of each column the successive months corresponding to the entire spread of the total contract time. The Schedule must contain monthly columns to cover the entire active period of contract, with extra columns for possible overruns in contract time.

**Computation of Anticipated Monthly Value of Work in Place**

Before presenting the form for approval, enter in each monthly column the dollar value (omit cents) of the increment of work anticipated to be put in place during that interval of time. This shall be the Contractor's best estimate of the rate of progress for each month. This section contains a suggested guide for the elapsed contract time vs. progress percentages.

The horizontal total of the monthly dollars shown for "Anticipated Monthly Value" must equal the contract price shown in the heading.

**Accumulated Scheduled Progress – %**

Entries on this line shall show in percentage of total completion the cumulative stage of progress that is scheduled to be reached at the end of each monthly interval. It is generally sufficient to state this anticipated progress to the nearest tenth of one percent, but for very large contracts it may be advisable to extend computations to the nearest hundredth.

The entry for the first month's column should be the % obtained by the anticipated monthly dollar value of work in place at the close of the first month being divided by the contract price.

The entry for the second month's column is obtained by the sum of the anticipated monthly dollar values of work in place for Columns 1 and 2 being divided by the contract price.

Enter in the third month's column the percentage computed similarly, using the sum of dollar values of work in place for Columns 1, 2, and 3. Continue in this manner for the succeeding monthly columns until "100" is reached in the final column.

**Charting Actual Progress.** The horizontal space extending through the monthly columns is divided into "Actual Monthly Value of Work in Place – \$" and "Actual Accumulated Progress – %." In each monthly column show the actual accumulated % of progress and the actual value of work in place for that month, as the work progresses. An anticipated complete shutdown at some stage in the work because of adverse seasonal weather or otherwise, as may occur in road work, excavation (grading), etc., is readily shown by a gap.

The Contractor's name shall be placed in the lower left-hand corner of the form, together with the signature and title of the employee who prepared the Schedule and the date. The form then shall be sent to the Architect for review. If the Architect considers that changes are necessary to make the Schedule more realistic, it will withhold approval and so advise the Contractor. When the form is acceptable and approved by the Architect, and the PHA/ IHA, it will be returned to the Contractor, who shall reproduce and submit the number and style of prints required by the PHA/ IHA.

Normal building construction experience has proved that the rate of overall progress (as measured by work in place) accelerates slowly at the start, reaches its peak in the middle third of the construction period, and tapers down at the close. The data following illustrate the general average expectancy of a well-balanced operation and may be used as a guide. If the proposed progress lies within reasonable range of these check points, the Schedule may be considered satisfactory insofar as the time-performance feature is involved.

<b>% of Contract Time</b>	<b>% of Accumulated Progress</b>
0	0
10	2
20	8
30	20
40	37
50	57
60	75
70	89
80	96
90	99
100	100

The foregoing percentages must be tempered by consideration of seasonal weather conditions and other known conditions which may affect the progress of the work. These percentages are offered for information only.

# Davis-Bacon and Related Acts Weekly Certified Payroll Form

(For Contractor's Optional Use; See Instructions at [www.dol.gov/whd/forms/wh347instr.htm](http://www.dol.gov/whd/forms/wh347instr.htm))



Unless otherwise noted, the information requested is specific to the named project below.  
Persons are not required to respond to the collection of information unless it displays a currently valid OMB control number.

Rev. January 2025  
OMB No.: 1235-0008  
Expires: 01/31/2028

SUBMISSION OF FINAL DBRA CERTIFIED PAYROLL FORM

PRIME CONTRACTOR

SUBCONTRACTOR

PROJECT NAME				PROJECT NO. or CONTRACT NO.			CERTIFIED PAYROLL NO.		PRIME CONTRACTOR'S/SUBCONTRACTOR'S BUSINESS NAME													
PROJECT LOCATION				WAGE DETERMINATION NO.			WEEK ENDING DATE		PRIME CONTRACTOR'S/SUBCONTRACTOR'S BUSINESS ADDRESS													
(1A)	(1B)	(1C)	(1D)	(1E)	(2)	(3)	(4)				(5)	(6A)	(6B)	(6C)	(7A)	(7B)	(8)			(9)		
WORKER ENTRY NO.	WORKER LAST NAME	WORKER FIRST NAME	WORKER MIDDLE INITIAL	WORKER IDENTIFYING NO.	(J) JOURNEYWORKER (RA) REGISTERED APPRENTICE	LABOR CLASSIFICATION	ST = STRAIGHT TIME OT = OVERTIME	(TOP) DAYS OF WORK WEEK (BOTTOM) DATES				TOTAL HOURS WORKED FOR WEEK	HOURLY WAGE RATE PAID FOR ST AND OT	TOTAL FRINGE BENEFIT CREDIT	PAYMENT IN LIEU OF FRINGE BENEFITS	GROSS AMT EARNED	GROSS AMT EARNED FOR ALL WORK	DEDUCTIONS FOR ALL WORK			NET PAY TO WORKER FOR ALL WORK	
								HOURS WORKED EACH DAY										TAX WITH-HOLDINGS	FICA	OTHER (MUST SPECIFY, SEE INSTRUCTIONS)		TOTAL DEDUCTIONS
							ST															
							OT															
							ST															
							OT															
							ST															
							OT															
							ST															
							OT															
							ST															
							OT															
							ST															
							OT															
							ST															
							OT															
							ST															
							OT															

While use of Form WH-347 itself is optional, covered contractors and subcontractors performing work on Federal or federally assisted construction contracts are required by the DBRA regulations and the contract clauses to submit payroll information on a weekly basis. The Copeland Act (40 U.S.C. § 3145) requires contractors and subcontractors performing work on Federal or federally financed construction contracts to, on a weekly basis, "furnish a statement on the wages paid each employee during the prior week." U.S. Department of Labor (DOL) Regulations at 29 C.F.R. § 5.5(a)(3)(ii) require contractors and subcontractors to submit weekly certified payrolls to the appropriate Federal agency if the agency is a party to the contract (or, if the agency is not such a party, to the applicant, sponsor, owner, or other entity, as the case may be, that maintains such records, for transmission to the Federal agency). Each certified payroll must be accompanied by a signed "Statement of Compliance" (e.g., page 2 of the WH-347 or another document with identical wording) indicating that the certified payrolls are accurate and complete, and that each laborer or mechanic has been paid not less than the required Davis-Bacon prevailing wage rate(s) (including any fringe benefits) for the work performed. DOL and contracting agencies receiving this information review the information to determine whether workers have received legally required wages and fringe benefits.

**Public Burden Statement**

We estimate that it will take an average of 55 minutes to complete this collection, including time for reviewing instructions, searching existing data sources, gathering and maintaining the data needed, and completing and reviewing the collection of information. If you have any comments regarding these estimates or any other aspect of this collection, including suggestions for reducing this burden, send them to the Administrator, Wage and Hour Division, U.S. Department of Labor, Room S3502, 200 Constitution Avenue, N.W. Washington, D.C. 20210 (over)

PROJECT NAME	PROJECT NO. or CONTRACT NO.	PAYROLL NO.	PRIME CONTRACTOR'S/SUBCONTRACTOR'S BUSINESS NAME
PROJECT LOCATION	WEEK ENDING DATE	CERTIFYING OFFICIAL'S NAME AND TITLE	

I paid or supervised the payment of the laborers or mechanics working on the above project during the stated time period. I certify the following:

- The payroll information submitted with this statement is correct and complete for the above project during the above period, and the wage and fringe benefit rates paid to the workers, including credit taken for the reasonably anticipated costs of a bona fide fringe benefit plan, fund or program, are not less than the applicable wage and fringe benefits rates for the classification(s) of work actually performed, as specified in the wage determination(s) incorporated into the contract.
- All regular payrolls and all other basic records that the contractor is required to maintain for this payroll period are complete and accurate and will be made available upon request from the agency or the Department of Labor.
- The classifications reported for each laborer or mechanic are the classification(s) of work that each worker actually performed.
- Any workers paid as apprentices during the above period are duly registered in a bona fide apprenticeship program registered with the Office of Apprenticeship, Employment and Training Administration, United States Department of Labor ("OA"), or a State Apprenticeship Agency ("SAA") recognized by Department of Labor. I have verified the registered apprenticeship program information provided below as accurate and applicable to any apprentices identified on page 1 of this form.

APPRENTICESHIP PROGRAM NAME	REGISTERED	NAME OF LABOR CLASSIFICATION
	<input type="checkbox"/> OA <input type="checkbox"/> SAA	
	<input type="checkbox"/> OA <input type="checkbox"/> SAA	
	<input type="checkbox"/> OA <input type="checkbox"/> SAA	

- Fringe benefits have been paid in cash and/or to bona fide fringe benefit plans, funds, or programs. Where the contractor is claiming an hourly credit for their contributions to or reasonably anticipated costs of a bona fide fringe benefit plan, fund, or program, provide plan information and the hourly credit claimed for each worker listed on the previous page of this form.

**HOURLY CREDIT FOR FRINGE BENEFITS**

*If an amount is listed in (6B) on the first page of this certified payroll form, enter the hourly credit claimed under each plan name, type and number for each worker and check whether the plan is funded or unfunded.*

NAME OF WORKER	FB NAME		FB NAME		FB NAME		FB NAME		FB NAME		FB NAME		TOTAL HOURLY CREDIT
	FB TYPE		FB TYPE		FB TYPE		FB TYPE		FB TYPE		FB TYPE		
	PLAN NO.		PLAN NO.		PLAN NO.		PLAN NO.		PLAN NO.		PLAN NO.		
	<input type="checkbox"/> Funded <input type="checkbox"/> Unfunded		<input type="checkbox"/> Funded <input type="checkbox"/> Unfunded		<input type="checkbox"/> Funded <input type="checkbox"/> Unfunded		<input type="checkbox"/> Funded <input type="checkbox"/> Unfunded		<input type="checkbox"/> Funded <input type="checkbox"/> Unfunded		<input type="checkbox"/> Funded <input type="checkbox"/> Unfunded		
	Hourly Credit	\$	Hourly Credit	\$	Hourly Credit	\$	Hourly Credit	\$	Hourly Credit	\$	Hourly Credit	\$	\$
	Hourly Credit	\$	Hourly Credit	\$	Hourly Credit	\$	Hourly Credit	\$	Hourly Credit	\$	Hourly Credit	\$	\$
	Hourly Credit	\$	Hourly Credit	\$	Hourly Credit	\$	Hourly Credit	\$	Hourly Credit	\$	Hourly Credit	\$	\$
	Hourly Credit	\$	Hourly Credit	\$	Hourly Credit	\$	Hourly Credit	\$	Hourly Credit	\$	Hourly Credit	\$	\$
	Hourly Credit	\$	Hourly Credit	\$	Hourly Credit	\$	Hourly Credit	\$	Hourly Credit	\$	Hourly Credit	\$	\$
	Hourly Credit	\$	Hourly Credit	\$	Hourly Credit	\$	Hourly Credit	\$	Hourly Credit	\$	Hourly Credit	\$	\$
	Hourly Credit	\$	Hourly Credit	\$	Hourly Credit	\$	Hourly Credit	\$	Hourly Credit	\$	Hourly Credit	\$	\$

- All workers on the project have been paid the full weekly wages earned, and no rebates or deductions have been or will be made either directly or indirectly, other than permissible deductions as defined in 29 CFR part 3.

ADDITIONAL REMARKS

SIGNATURE OF CERTIFYING OFFICIAL	DATE	TELEPHONE NUMBER	EMAIL ADDRESS
		(____) ____ - ____	

THE WILLFUL FALSIFICATION OF ANY OF THE ABOVE STATEMENTS MAY SUBJECT THE CONTRACTOR OR SUBCONTRACTOR TO CIVIL OR CRIMINAL PROSECUTION (SEE SECTION 1001 OF TITLE 18 AND SECTION 3729 OF TITLE 31 OF THE UNITED STATES CODE), AS WELL AS DEBARMENT FROM FUTURE FEDERAL AND FEDERALLY-ASSISTED CONTRACTS. INFORMATION REPORTED IN CERTIFIED PAYROLLS MAY BE SUBJECT TO DISCLOSURE IN RESPONSE TO A FREEDOM OF INFORMATION ACT REQUEST.

## Instructions

### General:

This form is to be used by HUD and local agency staff for recording information gathered during on-site interviews with laborers and mechanics employed on projects subject to Federal prevailing wage requirements. Typically, the staff that will conduct on-site interviews and use this form are HUD staff and fee construction inspectors, HUD Labor Standards staff, and local agency labor standards contract monitors.

Information recorded on the form HUD-11 is evaluated for general compliance and compared to certified payroll reports submitted by the respective employer. The comparison tests the veracity of the payroll reports and may be critical to the successful conclusion of enforcement actions in the event of labor standards violations. The thoroughness and accuracy of the information gathered during interviews is crucial.

Note that the interview itself and the information collected on the form HUD-11 are considered confidential. Interviews should be conducted individually and privately. All laborers and mechanics employed on the job site must be made available for interview at the interviewer's request. The employee's participation, however, is voluntary. Interviews shall be conducted in a manner and place that are conducive to the purposes of the interview and that cause the least inconvenience to the employer(s) and the employee(s).

### Completing the form HUD-11

Items 1a - 1c: Self-explanatory

Items 2a – 2d: Enter the employee's full name, a telephone number where the employee can be reached, email address and the employee's home address. Many construction workers use a temporary address in the locality of the project and have a more permanent address elsewhere from which mail may be forwarded to them. Obtain a more permanent address, if available. Ask the employee for a form of identification (e.g., driver's license) to verify their name.

Items 3a – 4c: Enter the employee's responses. Ask the employee about the frequency of pay (weekly, biweekly, semi-monthly or other).

Items 5 – 7: Be certain that the employee's responses are specific. For example, job classification (#5) must identify the trade involved (e.g., Carpenter, Electrician, Plumber) – responses such as "journeyman" or "mechanic" are not helpful for our purposes.

Items 8 – 12b: Self-explanatory

Items 13 – 15c: These items represent some of the most important information that can be gathered while conducting on-site interviews. Please be specific about the duties you observed the employee performing. It may be easiest to make these observations before initiating the interview. Please record any comments or remarks that may be helpful. For example, if the employee interviewed was working with a crew, how many workers were in the crew? Was the employee evasive?

The level of specificity that is warranted is directly related to the extent to which interview(s) or other observations indicate that there may be violations present. If interviews indicate that there may be underpayments involving a particular trade(s), the interviewer is encouraged to interview as many workers in that trade(s) that are available.

Items 16 – 17b: The information on the form HUD-11 may be reviewed for general compliance, initially. For example, are the job classification and wage rate stated by the employee compatible with the classifications and wage rates on the applicable wage decision? Are the duties observed by the interviewer consistent with the job classification?

Item 18: Please place here any additional information you may want to document or continuing information from other lines that do not fit in their block space.

Once the corresponding certified payroll reports are received, the information on the HUD-11 shall be compared to the payroll reports. Any discrepancies noted between the HUD-11 information and that on the payroll report shall be noted in Item 16, Remarks. If discrepancies are noted, follow-up actions to resolve the discrepancies must be taken.

# Record of Employee Interview

U.S. Department of Housing and Urban Development  
Office of Davis-Bacon and Labor Standards

OMB Approval No. 2501-0009  
(exp. 03/31/2028)

Public reporting burden for this collection of information is estimated to average 15 minutes per response, including the time for reviewing instructions, searching existing data sources, gathering and maintaining the data needed, and completing and reviewing the collection of information. This agency may not collect this information, and you are not required to complete this form, unless it displays a currently valid OMB control number. The information is collected to ensure compliance with the Federal labor standards by recording interviews with construction workers. The information collected will assist HUD in the conduct of compliance monitoring; the information will be used to test the veracity of certified payroll reports submitted by the employer. **Sensitive Information.** The information collected on this form is considered sensitive and is protected by the Privacy Act. The Privacy Act requires that these records be maintained with appropriate administrative, technical, and physical safeguards to ensure their security and confidentiality. In addition, these records should be protected against any anticipated threats or hazards to their security or integrity that could result in substantial harm, embarrassment, inconvenience, or unfairness to any individual on whom the information is maintained. **The information collected herein is voluntary, and any information provided shall be kept confidential.**

## Note: Please ensure responses are legible and easy to read.

1a. Project Name			2a. Employee's Full Name		
1b. Project Number			2b. Employee's Phone Number (including area code) and Email Address		
1c. Contractor or Subcontractor (Employer—not individual's name or supervisor's name)			2c. Employee's Home Address & Zip Code		
			2d. Verification of identification? Yes <input type="checkbox"/> No <input type="checkbox"/>		
3a. How long on this job and average weekly hours worked?	3b. Last date on this job before today?	3c. Number of hours last day on this job?	4a. Hourly Rate of Pay	4b. Fringe benefits? Medical Yes <input type="checkbox"/> No <input type="checkbox"/> Pension Yes <input type="checkbox"/> No <input type="checkbox"/>	4c. Frequency of Pay: Weekly <input type="checkbox"/> Biweekly <input type="checkbox"/> Semi-monthly <input type="checkbox"/> Other <input type="checkbox"/>

5. Your Job Classification(s) (list all and continue on a separate sheet if necessary):

6. Your Duties:

7. Tools or Equipment Used:

8. Are you an apprentice or trainee?	Y <input type="checkbox"/>	N <input type="checkbox"/>	10. Are you paid at least time and ½ (1.5x regular hourly rate) for all hours worked in excess of 40 in a week?	Y <input type="checkbox"/>	N <input type="checkbox"/>
8a. Have you provided a copy of your apprenticeship certificate?	<input type="checkbox"/>	<input type="checkbox"/>			
9. Are you paid for all hours worked?	<input type="checkbox"/>	<input type="checkbox"/>	11. Have you ever been threatened or coerced into giving up any part of your pay?	<input type="checkbox"/>	<input type="checkbox"/>

12a. Employee Signature	12b. Date
-------------------------	-----------

13. Duties Observed by the Interviewer (Please be specific):

14. Remarks

15a. Interviewer Name (please print)	15b. Signature of Interviewer	15c. Date of Interview
--------------------------------------	-------------------------------	------------------------

## Payroll Examination

16. Remarks	
17a. Signature of Payroll Examiner	17b. Date

**Record of  
Employee Interview**

**U.S. Department of Housing and Urban Development  
Office of Davis-Bacon and Labor Standards**

OMB Approval No. 2501-0009  
(exp. 03/31/2028)

18. Additional Remarks

[Empty rectangular box for additional remarks]

"General Decision Number: TX20260226 01/02/2026

Superseded General Decision Number: TX20250226

State: Texas

Construction Type: Residential

Counties: Callahan, Ector, Irion, Jones, Midland, Taylor and Tom Green Counties in Texas.

RESIDENTIAL CONSTRUCTION PROJECTS (consisting of single family homes and apartments up to and including 4 stories).

Modification Number 0 Publication Date 01/02/2026

ELEC0460-002 03/01/2000

Ector County

	Rates	Fringes
ELECTRICIAN.....	\$ 16.70	3.20+3.50%
-----		
ELEC0602-005 09/01/2022		

Midland County

	Rates	Fringes
ELECTRICIAN.....	\$ 26.07	12.63
-----		
ELEC0681-004 06/01/2025		

Callahan, Jones, and Taylor Counties

	Rates	Fringes
ELECTRICIAN.....	\$ 32.34	3.5%+10.20
-----		
ELEC0898-002 06/01/2009		

Irion and Tom Green Counties

	Rates	Fringes
Electrician.....	\$ 18.30	4.70
-----		
SUTX2009-179 06/03/2009		

	Rates	Fringes
CARPENTER.....	\$ 12.40	0.00
LABORER: Common or General.....	\$ 8.83	0.00
PAINTER: Brush and Roller.....	\$ 9.72	0.00
PLUMBER.....	\$ 15.50	2.00
ROOFER.....	\$ 9.35	0.00

SHEET METAL WORKER.....\$ 10.88 0.00

-----  
WELDERS - Receive rate prescribed for craft performing operation to which welding is incidental.

=====  
Note: Executive Order (EO) 13706, Establishing Paid Sick Leave for Federal Contractors applies to all contracts subject to the Davis-Bacon Act for which the contract is awarded (and any solicitation was issued) on or after January 1, 2017. If this contract is covered by the EO, the contractor must provide employees with 1 hour of paid sick leave for every 30 hours they work, up to 56 hours of paid sick leave each year. Employees must be permitted to use paid sick leave for their own illness, injury or other health-related needs, including preventive care; to assist a family member (or person who is like family to the employee) who is ill, injured, or has other health-related needs, including preventive care; or for reasons resulting from, or to assist a family member (or person who is like family to the employee) who is a victim of, domestic violence, sexual assault, or stalking. Additional information on contractor requirements and worker protections under the EO is available at <https://www.dol.gov/agencies/whd/government-contracts>.

Note: Executive Order 13658 generally applies to contracts subject to the Davis-Bacon Act that were awarded on or between January 1, 2015 and January 29, 2022, and that have not been renewed or extended on or after January 30, 2022. Executive Order 13658 does not apply to contracts subject only to the Davis-Bacon Related Acts regardless of when they were awarded. If a contract is subject to Executive Order 13658, the contractor must pay all covered workers at least \$13.30 per hour (or the applicable wage rate listed on this wage determination, if it is higher) for all hours spent performing on the contract in 2025. The applicable Executive Order minimum wage rate will be adjusted annually. Additional information on contractor requirements and worker protections under Executive Order 13658 is available at [www.dol.gov/whd/govcontracts](http://www.dol.gov/whd/govcontracts).

Unlisted classifications needed for work not included within the scope of the classifications listed may be added after award only as provided in the labor standards contract clauses (29CFR 5.5 (a) (1) (iii)).

-----  
The body of each wage determination lists the classifications and wage rates that have been found to be prevailing for the type(s) of construction and geographic area covered by the wage determination. The classifications are listed in alphabetical order under rate identifiers indicating whether the particular rate is a union rate (current union negotiated rate), a survey rate, a weighted union average rate, a state adopted rate, or a supplemental classification rate.

Union Rate Identifiers

A four-letter identifier beginning with characters other than ""SU"", ""UAVG"", ?SA?, or ?SC? denotes that a union rate was

prevailing for that classification in the survey. Example: PLUM0198-005 07/01/2024. PLUM is an identifier of the union whose collectively bargained rate prevailed in the survey for this classification, which in this example would be Plumbers. 0198 indicates the local union number or district council number where applicable, i.e., Plumbers Local 0198. The next number, 005 in the example, is an internal number used in processing the wage determination. The date, 07/01/2024 in the example, is the effective date of the most current negotiated rate.

Union prevailing wage rates are updated to reflect all changes over time that are reported to WHD in the rates in the collective bargaining agreement (CBA) governing the classification.

#### Union Average Rate Identifiers

The UAVG identifier indicates that no single rate prevailed for those classifications, but that 100% of the data reported for the classifications reflected union rates. EXAMPLE: UAVG-OH-0010 01/01/2024. UAVG indicates that the rate is a weighted union average rate. OH indicates the State of Ohio. The next number, 0010 in the example, is an internal number used in producing the wage determination. The date, 01/01/2024 in the example, indicates the date the wage determination was updated to reflect the most current union average rate.

A UAVG rate will be updated once a year, usually in January, to reflect a weighted average of the current rates in the collective bargaining agreements on which the rate is based.

#### Survey Rate Identifiers

The ""SU"" identifier indicates that either a single non-union rate prevailed (as defined in 29 CFR 1.2) for this classification in the survey or that the rate was derived by computing a weighted average rate based on all the rates reported in the survey for that classification. As a weighted average rate includes all rates reported in the survey, it may include both union and non-union rates. Example: SUFL2022-007 6/27/2024. SU indicates the rate is a single non-union prevailing rate or a weighted average of survey data for that classification. FL indicates the State of Florida. 2022 is the year of the survey on which these classifications and rates are based. The next number, 007 in the example, is an internal number used in producing the wage determination. The date, 6/27/2024 in the example, indicates the survey completion date for the classifications and rates under that identifier.

?SU? wage rates typically remain in effect until a new survey is conducted. However, the Wage and Hour Division (WHD) has the discretion to update such rates under 29 CFR 1.6(c)(1).

#### State Adopted Rate Identifiers

The ""SA"" identifier indicates that the classifications and prevailing wage rates set by a state (or local) government were adopted under 29 C.F.R 1.3(g)-(h). Example: SAME2023-007 01/03/2024. SA reflects that the rates are state adopted. ME refers to the State of Maine. 2023 is the year during which the state completed the survey on which the listed classifications and rates are based. The next number, 007 in the example, is an internal number used in producing the wage determination. The date, 01/03/2024 in the example, reflects the date on which

the classifications and rates under the ?SA? identifier took effect under state law in the state from which the rates were adopted.

-----  
WAGE DETERMINATION APPEALS PROCESS

1) Has there been an initial decision in the matter? This can be:

- a) a survey underlying a wage determination
- b) an existing published wage determination
- c) an initial WHD letter setting forth a position on a wage determination matter
- d) an initial conformance (additional classification and rate) determination

On survey related matters, initial contact, including requests for summaries of surveys, should be directed to the WHD Branch of Wage Surveys. Requests can be submitted via email to [davisbaconinfo@dol.gov](mailto:davisbaconinfo@dol.gov) or by mail to:

Branch of Wage Surveys  
Wage and Hour Division  
U.S. Department of Labor  
200 Constitution Avenue, N.W.  
Washington, DC 20210

Regarding any other wage determination matter such as conformance decisions, requests for initial decisions should be directed to the WHD Branch of Construction Wage Determinations. Requests can be submitted via email to [BCWD-Office@dol.gov](mailto:BCWD-Office@dol.gov) or by mail to:

Branch of Construction Wage Determinations  
Wage and Hour Division  
U.S. Department of Labor  
200 Constitution Avenue, N.W.  
Washington, DC 20210

2) If an initial decision has been issued, then any interested party (those affected by the action) that disagrees with the decision can request review and reconsideration from the Wage and Hour Administrator (See 29 CFR Part 1.8 and 29 CFR Part 7). Requests for review and reconsideration can be submitted via email to [dba.reconsideration@dol.gov](mailto:dba.reconsideration@dol.gov) or by mail to:

Wage and Hour Administrator  
U.S. Department of Labor  
200 Constitution Avenue, N.W.  
Washington, DC 20210

The request should be accompanied by a full statement of the interested party's position and any information (wage payment data, project description, area practice material, etc.) that the requestor considers relevant to the issue.

3) If the decision of the Administrator is not favorable, an interested party may appeal directly to the Administrative Review Board (formerly the Wage Appeals Board). Write to:

Administrative Review Board  
U.S. Department of Labor  
200 Constitution Avenue, N.W.

Washington, DC 20210.

=====

END OF GENERAL DECISION

..

<b>Bid Bond</b> (See Instructions on Page 3)	Date Bond Executed (Must Not Be Later Than Bid Opening Date)	<b>OMB Control Number: 9000-0001</b> <b>Expiration Date: 1/31/2027</b>
---	--	---

Principal (Legal Name And Business Address)	Type Of Organization ("X" One) <input type="checkbox"/> Individual <input type="checkbox"/> Partnership <input type="checkbox"/> Joint Venture <input type="checkbox"/> Corporation <input type="checkbox"/> Other (Specify)
	State Of Incorporation

Surety(ies) (Name And Business Address)

Penal Sum Of Bond				Bid Identification	
Percent Of Bid Price	Amount Not To Exceed			Bid Date	Invitation Number
	Million(s)	Thousand(s)	Hundred(s)		
For (Construction, Supplies Or Services)					

**Obligation:**

We, the Principal and Surety(ies) are firmly bound to the United States of America (hereinafter called the Government) in the above penal sum. For payment of the penal sum, we bind ourselves, our heirs, executors, administrators, and successors, jointly and severally. However, where the Sureties are corporations acting as co-sureties, we, the Sureties, bind ourselves in such sum "jointly and severally" as well as "severally" only for the purpose of allowing a joint action or actions against any or all of us. For all other purposes, each Surety binds itself, jointly and severally with the Principal, for the payment of the sum shown opposite the name of the Surety. If no limit of liability is indicated, the limit of liability is the full amount of the penal sum.

**Conditions:**

The Principal has submitted the bid identified above.

**Therefore:**

The above obligation is void if the Principal - (a) upon acceptance by the Government of the bid identified above, within the period specified therein for acceptance (sixty (60) days if no period is specified), executes the further contractual documents and gives the bond(s) required by the terms of the bid as accepted within the time specified (ten (10) days if no period is specified) after receipt of the forms by the Principal; or (b) in the event of failure to execute such further contractual documents and give such bonds, pays the Government for any cost of procuring the work which exceeds the amount of the bid.

Each Surety executing this instrument agrees that its obligation is not impaired by any extension(s) of the time for acceptance of the bid that the Principal may grant to the Government. Notice to the Surety(ies) of extension(s) is waived. However, waiver of the notice applies only to extensions aggregating not more than sixty (60) calendar days in addition to the period originally allowed for acceptance of the bid.

**Witness:**

The Principal and Surety(ies) executed this bid bond and affixed their seals on the above date.

**Principal**

Signature(s)	1.  (Seal)	2.  (Seal)	3.  (Seal)	Corporate Seal
Name(s) And Title(s) (Typed)	1.	2.	3.	

**Individual Surety(ies)**

Signature(s)	1.  (Seal)	2.  (Seal)
Name(s) (Typed)	1.	2.

**Corporate Surety(ies)**

<b>Surety A</b>	Name And Address		State Of Incorporation	Liability Limit (\$)	Corporate Seal
	Signature(s)	1.	2.		
	Name(s) And Title(s) (Typed)	1.	2.		
<b>Surety B</b>	Name And Address		State Of Incorporation	Liability Limit (\$)	Corporate Seal
	Signature(s)	1.	2.		
	Name(s) And Title(s) (Typed)	1.	2.		
<b>Surety C</b>	Name And Address		State Of Incorporation	Liability Limit (\$)	Corporate Seal
	Signature(s)	1.	2.		
	Name(s) And Title(s) (Typed)	1.	2.		
<b>Surety D</b>	Name And Address		State Of Incorporation	Liability Limit (\$)	Corporate Seal
	Signature(s)	1.	2.		
	Name(s) And Title(s) (Typed)	1.	2.		

<b>Surety E</b>	Name And Address		State Of Incorporation	Liability Limit (\$)	Corporate Seal
	Signature(s)	1.	2.		
	Name(s) And Title(s) (Typed)	1.	2.		
<b>Surety F</b>	Name And Address		State Of Incorporation	Liability Limit (\$)	Corporate Seal
	Signature(s)	1.	2.		
	Name(s) And Title(s) (Typed)	1.	2.		
<b>Surety G</b>	Name And Address		State Of Incorporation	Liability Limit (\$)	Corporate Seal
	Signature(s)	1.	2.		
	Name(s) And Title(s) (Typed)	1.	2.		

### Instructions

1. This form is authorized for use when a bid guaranty is required. Any deviation from this form will require the written approval of the Administrator of General Services.
2. Insert the full legal name and business address of the Principal in the space designated "Principal" on the face of the form. An authorized person shall sign the bond. Any person signing in a representative capacity (e.g., an attorney-in-fact) must furnish evidence of authority if that representative is not a member of the firm, partnership, or joint venture, or an officer of the corporation involved.
3. The bond may express penal sum as a percentage of the bid price. In these cases, the bond may state a maximum dollar limitation (e.g., 20% of the bid price but the amount not to exceed \_\_\_\_\_ dollars).
4. (a) Corporations executing the bond as sureties must appear on the Department of the Treasury's list of approved sureties and must act within the limitations listed therein. The value put into the Liability Limit block is the penal sum (i.e., the face value) of the bond, unless a co-surety arrangement is proposed.

(b) When multiple corporate sureties are involved, their names and addresses shall appear in the spaces (Surety A, Surety B, etc.) headed "Corporate Surety(ies)." In the space designated "Surety(ies)" on the face of the form, insert only the letter identifier corresponding to each of the sureties. Moreover, when co-surety arrangements exist, the parties may allocate their respective limitations of liability under the bond, provided that the sum total of their liability equals 100% of the bond penal sum.

(c) When individual sureties are involved, a completed [Affidavit of Individual Surety \(Standard Form 28\)](#) for each individual surety, shall accompany the bond. The Government may require the surety to furnish additional substantiating information concerning its financial capability.

5. Corporations executing the bond shall affix their corporate seals. Individuals shall execute the bond opposite the word "Corporate Seal"; and shall affix an adhesive seal if executed in Maine, New Hampshire, or any other jurisdiction requiring adhesive seals.
6. Type the name and title of each person signing this bond in the space provided.
7. In its application to negotiated contracts, the terms "bid" and "bidder" shall include "proposal" and "offeror."

---

Paperwork Reduction Act Statement - This information collection meets the requirements of 44 USC § 3507, as amended by section 2 of the Paperwork Reduction Act of 1995. You do not need to answer these questions unless we display a valid Office of Management and Budget (OMB) control number. The OMB control number for this collection is 9000-0001. We estimate that it will take 1 hour to read the instructions, gather the facts, and answer the questions. Send only comments relating to our time estimate, including suggestions for reducing this burden, or any other aspects of this collection of information to: General Services Administration, Regulatory Secretariat Division (MVCB), 1800 F Street, NW, Washington, DC 20405.

<b>Payment Bond</b> (See Instructions On Page 3)	Date Bond Executed (Must be same or later than date of contract)	<b>OMB Control Number: 9000-0001</b> <b>Expiration Date: 1/31/2027</b>
---	--	---

Principal (Legal name and business address)	Type Of Organization ("X" one)			
	<input type="checkbox"/> Individual <input type="checkbox"/> Partnership <input type="checkbox"/> Joint Venture <input type="checkbox"/> Corporation <input type="checkbox"/> Other (Specify)			
	State Of Incorporation			
Surety(ies) (Name(s) and business address(es))	Penal Sum Of Bond			
	Million(s)	Thousand(s)	Hundred(s)	Cents
	Contract Date		Contract Number	

**Obligation:**

We, the Principal and Surety(ies), are firmly bound to the United States of America (hereinafter called the Government) in the above penal sum. For payment of the penal sum, we bind ourselves, our heirs, executors, administrators, and successors, jointly and severally. However, where the Sureties are corporations acting as co-sureties, we, the Sureties, bind ourselves in such sum "jointly and severally" as well as "severally" only for the purpose of allowing a joint action or actions against any or all of us. For all other purposes, each Surety binds itself, jointly and severally with the Principal, for the payment of the sum shown opposite the name of the Surety. If no limit is indicated, the limit of liability is the full amount of the penal sum.

**Conditions:**

The above obligation is void if the Principal promptly makes payment to all persons having a direct relationship with the Principal or a subcontractor of the Principal for furnishing labor, material or both in the prosecution of the work provided for in the contract identified above, and any authorized modifications of the contract that subsequently are made. Notice of those modifications to the Surety(ies) are waived.

**Witness:**

The Principal and Surety(ies) executed this payment bond and affixed their seals on the above date.

**Principal**

Signature(s)	1.	2.	3.	Corporate Seal
	(Seal)	(Seal)	(Seal)	
Name(s) & Title(s) (Typed)	1.	2.	3.	

**Individual Surety(ies)**

Signature(s)	1. (Seal)	2. (Seal)
Name(s) (Typed)	1.	2.

**Corporate Surety(ies)**

<b>Surety A</b>	Name & Address	State Of Incorporation	Liability Limit \$	Corporate Seal
	Signature(s)	2.		
	Name(s) & Title(s) (Typed)	2.		

**Corporate Surety(ies) (Continued)**

<b>Surety B</b>	Name & Address		State Of Incorporation	Liability Limit \$	Corporate Seal
	Signature(s)	1.	2.		
	Name(s) & Title(s) (Typed)	1.	2.		
<b>Surety C</b>	Name & Address		State Of Incorporation	Liability Limit \$	Corporate Seal
	Signature(s)	1.	2.		
	Name(s) & Title(s) (Typed)	1.	2.		
<b>Surety D</b>	Name & Address		State Of Incorporation	Liability Limit \$	Corporate Seal
	Signature(s)	1.	2.		
	Name(s) & Title(s) (Typed)	1.	2.		
<b>Surety E</b>	Name & Address		State Of Incorporation	Liability Limit \$	Corporate Seal
	Signature(s)	1.	2.		
	Name(s) & Title(s) (Typed)	1.	2.		
<b>Surety F</b>	Name & Address		State Of Incorporation	Liability Limit \$	Corporate Seal
	Signature(s)	1.	2.		
	Name(s) & Title(s) (Typed)	1.	2.		
<b>Surety G</b>	Name & Address		State Of Incorporation	Liability Limit \$	Corporate Seal
	Signature(s)	1.	2.		
	Name(s) & Title(s) (Typed)	1.	2.		

## Instructions

1. This form, for the protection of persons supplying labor and material, is used when a payment bond is required under 40 USC Chapter 31, Subchapter III, Bonds. Any deviation from this form will require the written approval of the Administrator of General Services.
2. Insert the full legal name and business address of the Principal in the space designated "Principal" on the face of the form. An authorized person shall sign the bond. Any person signing in a representative capacity (e.g., an attorney-in-fact) must furnish evidence of authority if that representative is not a member of the firm, partnership, or joint venture, or an officer of the corporation involved.
3. (a) Corporations executing the bond as sureties must appear on the Department of the Treasury's list of approved sureties and must act within the limitations listed therein. The value put into the Liability Limit block is the penal sum (i.e., the face value) of the bond, unless a co-surety arrangement is proposed.  
  
(b) When multiple corporate sureties are involved, their names and addresses shall appear in the spaces (Surety A, Surety B, etc.) headed "Corporate Surety(ies)." In the space designated "Surety(ies)" on the face of the form, insert only the letter identifier corresponding to each of the sureties. Moreover, when co-surety arrangements exist, the parties may allocate their respective limitations of liability under the bonds, provided that the sum total of their liability equals 100% of the bond penal sum.  
  
(c) When individual sureties are involved, a completed Affidavit of Individual Surety (Standard Form 28) for each individual surety shall accompany the bond. The Government may require the surety to furnish additional substantiating information concerning its financial capability.
4. Corporations executing the bond shall affix their corporate seals. Individuals shall execute the bond opposite the words "Corporate Seal", and shall affix an adhesive seal if executed in Maine, New Hampshire, or any other jurisdiction requiring adhesive seals.
5. Type the name and title of each person signing this bond in the space provided.

## Paperwork Reduction Act Statement

This information collection meets the requirements of 44 USC § 3507, as amended by section 2 of the Paperwork Reduction Act of 1995. You do not need to answer these questions unless we display a valid Office of Management and Budget (OMB) control number. The OMB control number for this collection is 9000-0001. We estimate that it will take 1 hour to read the instructions, gather the facts, and answer the questions. Send only comments relating to our time estimate, including suggestions for reducing this burden, or any other aspects of this collection of information to: U.S. General Services Administration, Regulatory Secretariat Division (MVCB), 1800 F Street, NW, Washington, DC 20405.

<b>Performance Bond</b>	Date Bond Executed (Must be same or later than date of contract)	<b>OMB Control Number: 9000-0001</b> <b>Expiration Date: 1/31/2027</b>
-------------------------	--	---

See Instructions on page 3

Principal (Legal name and business address)	Type of Organization ("X" one)			
	<input type="checkbox"/> Individual	<input type="checkbox"/> Partnership		<input type="checkbox"/> Corporation
	<input type="checkbox"/> Joint Venture	<input type="checkbox"/> Other (Specify)		
	State of Incorporation			
Surety(ies) (Name(s) and business address(es))	Penal Sum of Bond			
	Million(s)	Thousand(s)	Hundred(s)	Cents
	Contract Date		Contract Number	

Obligation:

We, the Principal and Surety(ies), are firmly bound to the United States of America (hereinafter called the Government) in the above penal sum. For payment of the penal sum, we bind ourselves, our heirs, executors, administrators, and successors, jointly and severally. However, where the Sureties are corporations acting as co-sureties, we, the Sureties, bind ourselves in such sum "jointly and severally" as well as "severally" only for the purpose of allowing a joint action or actions against any or all of us. For all other purposes, each Surety binds itself, jointly and severally with the Principal, for the payment of the sum shown opposite the name of the Surety. If no limit of liability is indicated, the limit of liability is the full amount of the penal sum.

Conditions:

The Principal has entered into the contract identified above.

Therefore:

The above obligation is void if the Principal-

- (a) (1) Performs and fulfills all the understanding, covenants, terms, conditions, and agreements of the contract during the original term of the contract and any extensions thereof that are granted by the Government, with or without notice of the Surety(ies) and during the life of any guaranty required under the contract, and
- (2) Performs and fulfills all the undertakings, covenants, terms, conditions, and agreements of any and all duly authorized modifications of the contract that hereafter are made. Notice of those modifications to the Surety(ies) are waived.
- (b) Pays to the Government the full amount of the taxes imposed by the Government, if the said contract is subject to 41 USC Chapter 31, Subchapter III, Bonds, which are collected, deducted, or withheld from wages paid by the Principal in carrying out the construction contract with respect to which this bond is furnished.

Witness:

The Principal and Surety(ies) executed this performance bond and affixed their seals on the above date.

**Principal**

Signature(s)	1. _____ (Seal)	2. _____ (Seal)	3. _____ (Seal)	Corporate Seal
Name(s) & Title(s) (Typed)	1. _____	2. _____	3. _____	

**Individual Surety(ies)**

Signature(s)	1. _____ (Seal)	2. _____ (Seal)
Name(s) (Typed)	1. _____	2. _____

**Corporate Surety(ies)**

	Name & Address	State of Incorporation	Liability Limit (\$)	
<b>Surety A</b>	Signature(s)	1. _____	2. _____	Corporate Seal
	Name(s) & Title(s) (Typed)	1. _____	2. _____	
	Name & Address	State of Incorporation	Liability Limit (\$)	
<b>Surety B</b>	Signature(s)	1. _____	2. _____	Corporate Seal
	Name(s) & Title(s) (Typed)	1. _____	2. _____	
	Name & Address	State of Incorporation	Liability Limit (\$)	
<b>Surety C</b>	Signature(s)	1. _____	2. _____	Corporate Seal
	Name(s) & Title(s) (Typed)	1. _____	2. _____	
	Name & Address	State of Incorporation	Liability Limit (\$)	
<b>Surety D</b>	Signature(s)	1. _____	2. _____	Corporate Seal
	Name(s) & Title(s) (Typed)	1. _____	2. _____	
	Name & Address	State of Incorporation	Liability Limit (\$)	
<b>Surety E</b>	Signature(s)	1. _____	2. _____	Corporate Seal
	Name(s) & Title(s) (Typed)	1. _____	2. _____	
	Name & Address	State of Incorporation	Liability Limit (\$)	

**Corporate Surety(ies) (continued)**

<b>Surety F</b>	Name & Address		State of Incorporation	Liability Limit (\$)	Corporate Seal
	Signature(s)	1.	2.		
	Name(s) & Title(s) (Typed)	1.	2.		
<b>Surety G</b>	Name & Address		State of Incorporation	Liability Limit (\$)	Corporate Seal
	Signature(s)	1.	2.		
	Name(s) & Title(s) (Typed)	1.	2.		

<b>Bond Premium</b> 	Rate Per Thousand (\$)	Total (\$)
---	------------------------	------------

**Instructions**

- This form is authorized for use in connection with Government contracts. Any deviation from this form will require the written approval of the Administrator of General Services.
- Insert the full legal name and business address of the Principal in the space designated "Principal" on the face of the form. An authorized person shall sign the bond. Any person signing in a representative capacity (e.g., an attorney-in-fact) must furnish evidence of authority if that representative is not a member of the firm, partnership, or joint venture, or an officer of the corporation involved.
- Corporations executing the bond as sureties must appear on the Department of the Treasury's list of approved sureties and must act within the limitations listed therein. The value put into the Liability Limit block is the penal sum (i.e., the face value) of bonds, unless a co-surety arrangement is proposed.
  - When multiple corporate sureties are involved, their names and addresses shall appear in the spaces (Surety A, Surety B, etc.) headed "Corporate Surety(ies)." In the space designated "Surety(ies)" on the face of the form, insert only the letter identifier corresponding to each of the sureties. Moreover, when co-surety arrangements exist, the parties may allocate their respective limitations of liability under the bonds, provided that the sum total of their liability equals 100% of the bond penal sum.
  - When individual sureties are involved, a completed Affidavit of Individual Surety (Standard Form 28) for each individual surety shall accompany the bond. The government may require the surety to furnish additional substantiating information concerning its financial capability.
- Corporations executing the bond shall affix their corporate seals. Individuals shall execute the bond opposite the words "Corporate Seal", and shall affix an adhesive seal if executed in Maine, New Hampshire, or any other jurisdiction requiring adhesive seals.
- Type the name and title of each person signing this bond in the space provided.

## **Paperwork Reduction Act Statement**

This information collection meets the requirements of 44 USC § 3507, as amended by section 2 of the Paperwork Reduction Act of 1995. You do not need to answer these questions unless we display a valid Office of Management and Budget (OMB) control number. The OMB control number for this collection is 9000-0001. We estimate that it will take 1 hour to read the instructions, gather the facts, and answer the questions. Send only comments relating to our time estimate, including suggestions for reducing this burden, or any other aspects of this collection of information to: U.S. General Services Administration, Regulatory Secretariat Division (MVCB), 1800 F Street, NW, Washington, DC 20405.

# **III. Exhibits & Attachments**

## **B. Scope of Work & Unit Information**

**Abilene Housing Authority - Brailsford Complex B Apartments**  
**2250 Vogel St., Unit B25 - 2 Bedroom, 1 Bath (Total SF 1277)**  
**A2.01B UNIT PLAN RENOVATION - TYPE F4 (UNIT B25)**

Row#	Description	Quantity	Units
1	<b>Division 2 - Existing Conditions</b>		
2	All demo work is include in Divisions		
3	Final clean of project	1277	sf
4	<b>Division 3 - Concrete</b>		
5	Not Used		
6	<b>Division 4 - Masonry</b>		
7	Not Used		
8	<b>Division 5 - Metals</b>		
9	Not Used		
10	<b>Division 6 - Wood and Plastics</b>		
11	Demo and new sink base	6	lf
12	Demo and new kitchen base cabinets	17	lf
13	Demo and new kitchen wall mount	17	lf
14	Demo and new wire shelving	27	lf
15	<b>Division 7 - Thermal Protection</b>		
16	Clean tub/surround, new caulk	2	ea.
17	<b>Division 8 - Openings</b>		
18	Replace mag latch, and adjust doors	3	set
19	Demo and new door locksets	11	ea.
20	Demo and dispose of screen door	1	ea.
21	Demo and new door hinges	33	ea.
22	<b>Division 9 - Finishes</b>		
23	Demo and new gypsum ceiling	1277	sf
24	protection of existing area	1277	sf
25	Paint new gyp ceiling	1277	sf
26	New furrdowns	20	lf
27	Repair and touchup walls as needed	1277	sf
28	Patch and clean flooring as needed	1277	sf
29	<b>Division 10 - Specialties</b>		
30	Demo and new toilet paper dispenser	2	ea.
31	Demo and new towel bar	2	ea.
32	Demo and new mirrors	2	ea.
33	<b>Division 11 - Equipment</b>		
34	Appliances (demo and new)		
35	Refrigerators, with icemaker	1	ea.
36	Stove/Oven	1	ea.
37	Vent hood	1	ea.
38	Microwave	1	ea.
39	Dishwasher	1	ea.
40	<b>Division 12 - Furnishings</b>		
41	Not Used		
42	<b>Division 13 - Special Construction</b>		
43	Not Used		

**Abilene Housing Authority - Brailsford Complex B Apartments  
 2250 Vogel St., Unit B25 - 2 Bedroom, 1 Bath (Total SF 1277)  
 A2.01B UNIT PLAN RENOVATION - TYPE F4 (UNIT B25)**

44	<b>Division 21 - Fire Suppression</b>		
45	Not Used		
46	<b>Division 22 - Plumbing</b>		
47	Demo and new water closet	2	ea.
48	Demo and new lavatory, ctr mount, w/trim	2	ea.
49	Demo and new kitchen sink, w/trim	1	ea.
50	Demo and new tub trim, faucets, shower	2	set
51	<b>Division 23 - HVAC</b>		
52	Demo and new restroom vent fans	2	ea.
53	<b>Division 26 - Electrical</b>		
54	Demo and new ceiling fans	5	ea.
55	Demo and new 6" can light retrofit to LED	6	ea.
56	Demo and new 12" satin nickel flush LED fixture	1	ea.
57	Demo and new 24" x 13" satin nickel flush LED	1	ea.
58	Demo and new 24" linear bath LED fixture	2	ea.
59	Demo and new duplex receptacle, cover	37	ea.
60	Demo and new toggle switch, cover	19	ea.
61	<b>Division 27 - Communications</b>		
62	Not Used		
63	<b>Division 28 - Electrical Safety and Security</b>		
64	Smoke Detectors	6	ea.
65	<b>Division 31 - Earthwork</b>		
66	Not Used		
67	<b>Division 32 - Site Improvements</b>		
68	Not Used		
69	<b>Division 33 - Site Utilities</b>		
70	Not Used		

**End of Scope of Work for Unit B25**

**Abilene Housing Authority - Brailsford Complex D Apartments**  
**2250 Vogel St., Unit D6 - 2 Bedroom, 1 Bath (Total SF 795)**  
**A2.01D UNIT PLAN RENOVATION - TYPE F2 (UNIT D6)**

Row#	Description	Quantity	Units
1	<b>Division 2 - Existing Conditions</b>		
2	All demo work is include in Divisions		
3	Final clean of project	795	sf
4	<b>Division 3 - Concrete</b>		
5	Not Used		
6	<b>Division 4 - Masonry</b>		
7	Not Used		
8	<b>Division 5 - Metals</b>		
9	Not Used		
10	<b>Division 6 - Wood and Plastics</b>		
11	Demo and new sink base	4	lf
12	Demo and new kitchen base cabinets	12	lf
13	Demo and new kitchen wall mount	10	lf
14	Demo and new wire shelving	37	lf
15	<b>Division 7 - Thermal Protection</b>		
16	Clean tub/surround, new caulk	1	ea.
17	<b>Division 8 - Openings</b>		
18	Replace mag latch, and adjust doors	2	set
19	Demo and new door locksets	9	ea.
20	Demo and new door hinges	27	ea.
21	<b>Division 9 - Finishes</b>		
22	Demo and replace LVT	794	sf
23	protection of existing area	794	sf
24	Repair and touchup walls as needed	794	sf
25	<b>Division 10 - Specialties</b>		
26	Demo and new toilet paper dispenser	1	ea.
27	Demo and new towel bar	2	ea.
28	Demo and new mirrors	1	ea.
29	Demo and new curved shower rod	1	ea.
30	<b>Division 11 - Equipment</b>		
31	Appliances (demo and new)		
32	Refrigerators, with icemaker	1	ea.
33	Stove/Oven	1	ea.
34	Vent hood	1	ea.
35	Microwave	1	ea.
36	Dishwasher	1	ea.
37	<b>Division 12 - Furnishings</b>		
38	Not Used		
39	<b>Division 13 - Special Construction</b>		
40	Not Used		
41	<b>Division 21 - Fire Suppression</b>		
42	Not Used		
43	<b>Division 22 - Plumbing</b>		

**Abilene Housing Authority - Brailsford Complex D Apartments**  
**2250 Vogel St., Unit D6 - 2 Bedroom, 1 Bath (Total SF 795)**  
**A2.01D UNIT PLAN RENOVATION - TYPE F2 (UNIT D6)**

44	Demo and new water closet	1	ea.
45	Demo and new lavatory, ctr mount, w/trim	1	ea.
46	Demo and new kitchen sink, w/trim	1	ea.
47	Demo and new tub trim, faucets, shower	1	set
48	<b>Division 23 - HVAC</b>		
49	Demo and new restroom vent fans	1	ea.
50	<b>Division 26 - Electrical</b>		
51	Demo and new ceiling fans	3	ea.
52	Demo and new 6" can light retrofit to LED	4	ea.
53	Demo and new 12" satin nickel flush LED fixture	1	ea.
54	Demo and new 24" x 13" satin nickel flush LED fixture	1	ea.
55	Demo and new 24" linear bath LED fixture	1	ea.
56	Demo and new duplex receptacle, cover	23	ea.
57	Demo and new toggle switch, cover	17	ea.
58	<b>Division 27 - Communications</b>		
59	Not Used		
60	<b>Division 28 - Electrical Safety and Security</b>		
61	Smoke Detectors	4	ea.
62	<b>Division 31 - Earthwork</b>		
63	Not Used		
64	<b>Division 32 - Site Improvements</b>		
65	Not Used		
66	<b>Division 33 - Site Utilities</b>		
67	Not Used		

**End of Scope of Work for Unit D6**

**Abilene Housing Authority - Riviera Apartments**  
**3001 N 6th St Unit 102, Abilene, TX 79603 - 3 Bedroom, 2 Bath (Total SF 795)**  
**A-2.01R UNIT PLAN MAKE READY - 3 BEDROOM TYPE (UNIT 102)**

Row#	Description	Quantity	Units
1	<b>Division 2 - Existing Conditions</b>		
2	All demo work is include in Divisions below		
3	Final clean of project	795	sf
4	<b>Division 3 - Concrete</b>		
5	Not Used		
6	<b>Division 4 - Masonry</b>		
7	Not Used		
8	<b>Division 5 - Metals</b>		
9	Not Used		
10	<b>Division 6 - Wood and Plastics</b>		
11	Demo and new sink base	8	lf
12	Demo and new kitchen base cabinets	12	lf
13	Demo and new kitchen wall mount cabinets	16	lf
14	Demo and new wire shelving	25	lf
15	<b>Division 7 - Thermal Protection</b>		
16	Clean tub/surround, new caulk	2	ea.
17	<b>Division 8 - Openings</b>		
18	Demo and new door locksets	10	ea.
19	Demo and new door hinges	29	ea.
20	<b>Division 9 - Finishes</b>		
21	Demo and replace stair treads	14	ea.
22	Demo and replace stair risers	14	ea.
23	protection of existing area	976	sf
24	Demo and replace flooring (LVT)	976	sf
25	Repair and touchup walls as needed	976	sf
26	<b>Division 10 - Specialties</b>		
27	Demo and new toilet paper dispenser	2	ea.
28	Demo and new towel bar	4	ea.
29	Demo and new mirrors	2	ea.
30	Demo and new curved shower rod	1	ea.
31	<b>Division 11 - Equipment</b>		
32	Appliances (demo and new)		
33	Refrigerators, with icemaker	1	ea.
34	Stove/Oven	1	ea.
35	Vent hood	1	ea.
36	Microwave	1	ea.
37	Dishwasher	1	ea.
38	<b>Division 12 - Furnishings</b>		
39	Not Used		
40	<b>Division 13 - Special Construction</b>		
41	Not Used		
42	<b>Division 21 - Fire Suppression</b>		
43	Not Used		

**Abilene Housing Authority - Riviera Apartments**  
**3001 N 6th St Unit 102, Abilene, TX 79603 - 3 Bedroom, 2 Bath (Total SF 795)**  
**A-2.01R UNIT PLAN MAKE READY - 3 BEDROOM TYPE (UNIT 102)**

44	<b>Division 22 - Plumbing</b>		
45	Demo and new water closet	2	ea.
46	Demo and new lavatory, ctr mount, w/trim	2	ea.
47	Demo and new kitchen sink, w/trim	1	ea.
48	Demo and new tub trim, faucets, shower	2	set
49	<b>Division 23 - HVAC</b>		
50	Demo and new restroom vent fans	2	ea.
51	<b>Division 26 - Electrical</b>		
52	Demo and new ceiling fans	4	ea.
53	Demo and new 6" can light retrofit to LED	5	ea.
54	Demo and new 12" satin nickel flush LED fixture	1	ea.
55	Demo and new 24" x 13" satin nickel flush LED fixture	1	ea.
56	Demo and new 24" linear bath LED fixture	2	ea.
57	Demo and new duplex receptacle, cover	26	ea.
58	Demo and new toggle switch, cover	16	ea.
59	<b>Division 27 - Communications</b>		
60	Not Used		
61	<b>Division 28 - Electrical Safety and Security</b>		
62	Smoke Detectors	5	ea.
63	<b>Division 31 - Earthwork</b>		
64	Not Used		
65	<b>Division 32 - Site Improvements</b>		
66	Not Used		
67	<b>Division 33 - Site Utilities</b>		
68	Not Used		

**End of Scope of Work for Unit 102**

**Abilene Housing Authority - Riviera Apartments**  
**3001 N 6th St Unit 208, Abilene, TX 79603 - 4 Bedroom, 2 Bath (Total SF 976)**  
**A-2.02R UNIT PLAN MAKE READY - 4 BEDROOM TYPE (UNIT 208)**

Row#	Description	Quantity	Units
1	<b>Division 2 - Existing Conditions</b>		
2	All demo work is include in Divisions below		
3	Final clean of project	976	sf
4	<b>Division 3 - Concrete</b>		
5	Not Used		
6	<b>Division 4 - Masonry</b>		
7	Not Used		
8	<b>Division 5 - Metals</b>		
9	Not Used		
10	<b>Division 6 - Wood and Plastics</b>		
11	Demo and new sink base	4	lf
12	Demo and new kitchen base cabinets	11	lf
13	Demo and new kitchen wall mount cabinets	14	lf
14	Demo and new hall linen cabinet doors	2	ea.
15	<b>Division 7 - Thermal Protection</b>		
16	Clean tub/surround, new caulk	2	ea.
17	<b>Division 8 - Openings</b>		
18	Demo and new door locksets	14	ea.
19	Demo and new door hinges	42	ea.
20	<b>Division 9 - Finishes</b>		
21	protection of existing area	796	sf
22	Repair any damage flooring	796	sf
23	Repair and touchup walls as needed	796	sf
24	<b>Division 10 - Specialties</b>		
25	Demo and new toilet paper dispenser	2	ea.
26	Demo and new towel bar	4	ea.
27	Demo and new mirrors	2	ea.
28	Demo and new curved shower rod	2	ea.
29	<b>Division 11 - Equipment</b>		
30	Appliances (demo and new)		
31	Refrigerators, with icemaker	1	ea.
32	Stove/Oven	1	ea.
33	Vent hood	1	ea.
34	Microwave	1	ea.
35	Dishwasher	1	ea.
36	<b>Division 12 - Furnishings</b>		
37	Not Used		
38	<b>Division 13 - Special Construction</b>		
39	Not Used		
40	<b>Division 21 - Fire Suppression</b>		
41	Not Used		
42	<b>Division 22 - Plumbing</b>		
43	Demo and new water closet	2	ea.

**Abilene Housing Authority - Riviera Apartments**  
**3001 N 6th St Unit 208, Abilene, TX 79603 - 4 Bedroom, 2 Bath (Total SF 976)**  
**A-2.02R UNIT PLAN MAKE READY - 4 BEDROOM TYPE (UNIT 208)**

44	Demo and new lavatory, ctr mount, w/trim	2	ea.
45	Demo and new kitchen sink, w/trim	1	ea.
46	Demo and new tub trim, faucets, shower	2	set
47	<b>Division 23 - HVAC</b>		
48	Demo and new restroom vent fans	2	ea.
49	<b>Division 26 - Electrical</b>		
50	Demo and new ceiling fans	6	ea.
51	Demo and new 6" can light retrofit to LED	5	ea.
52	Demo and new 12" satin nickel flush LED fixture	1	ea.
53	Demo and new 24" x 13" satin nickel flush LED fixture	1	ea.
54	Demo and new 24" linear bath LED fixture	2	ea.
55	Demo and new duplex receptacle, cover	24	ea.
56	Demo and new toggle switch, cover	16	ea.
57	<b>Division 27 - Communications</b>		
58	Not Used		
59	<b>Division 28 - Electrical Safety and Security</b>		
60	Smoke Detectors	5	ea.
61	<b>Division 31 - Earthwork</b>		
62	Not Used		
63	<b>Division 32 - Site Improvements</b>		
64	Not Used		
65	<b>Division 33 - Site Utilities</b>		
66	Not Used		

**End of Scope of Work for Unit 208**

## **III. Exhibits & Attachments**

### **B. Scope of Work & Unit Information**

- 1. Riviera and Brailsford Unit Renovation Construction Drawings  
(Attachment H1)**

# ABILENE HOUSING AUTHORITY

## PROJECT NUMBER: 2026-001 UNIT RENOVATIONS

RIVIERA APARTMENTS UNIT RENOVATIONS  
3001 NORTH SIXTH STREET  
ABILENE, TEXAS 79603

VICINITY MAP:



SITE LOCATION

**CONSTRUCTION CODES:**

2021 INTERNATIONAL BUILDING CODE  
2021 INTERNATIONAL EXISTING BUILDING CODE  
2021 INTERNATIONAL MECHANICAL CODE  
2021 IECC ENERGY CONSERVATION CODE  
2020 NATIONAL ELECTRIC CODE  
AMERICANS WITH DISABILITIES ACT ACCESSIBILITY GUIDELINES  
TEXAS ACCESSIBILITY STANDARDS

BUILDING OCCUPANCY: R3  
CONSTRUCTION TYPE: TYPE V8

**SHEET INDEX**

ARCHITECTURAL	REVISION	DATE
COVER SHEET		
A-1.01B SITE PLAN - BRAILSFORD COMPLEX B		
A-2.01B UNIT PLAN RENOVATION - TYPE F4 (Unit B25)		
A-1.01D SITE PLAN - BRAILSFORD COMPLEX D		
A-2.01D UNIT PLAN RENOVATION - TYPE F2 (Unit D6)		
A-1.01R SITE PLAN - RIVIERA APARTMENTS		
A-2.01R UNIT PLAN MAKE READY - 3 BEDROOM TYPE (Unit 102)		
A-2.02R UNIT PLAN MAKE READY - 4 BEDROOM TYPE (Unit 208)		

**DEFINITIONS:**

RENOVATION UNITS: DESIGNATED FOR RENOVATION WILL HAVE INTERIORS FINISHED FOR OCCUPANCY WITH NEW MATERIALS, FIXTURES & FINISHES WILL BE INSTALLED ACCORDING TO PLANS AND SPECIFICATIONS.

BRAILSFORD 'D' APARTMENTS UNIT RENOVATIONS  
2250 VOGEL ST.  
ABILENE, TEXAS 79603

VICINITY MAP:



SITE LOCATION

BRAILSFORD 'B' APARTMENTS UNIT RENOVATIONS  
2100 VOGEL ST.  
ABILENE, TEXAS 79603

VICINITY MAP:



SITE LOCATION

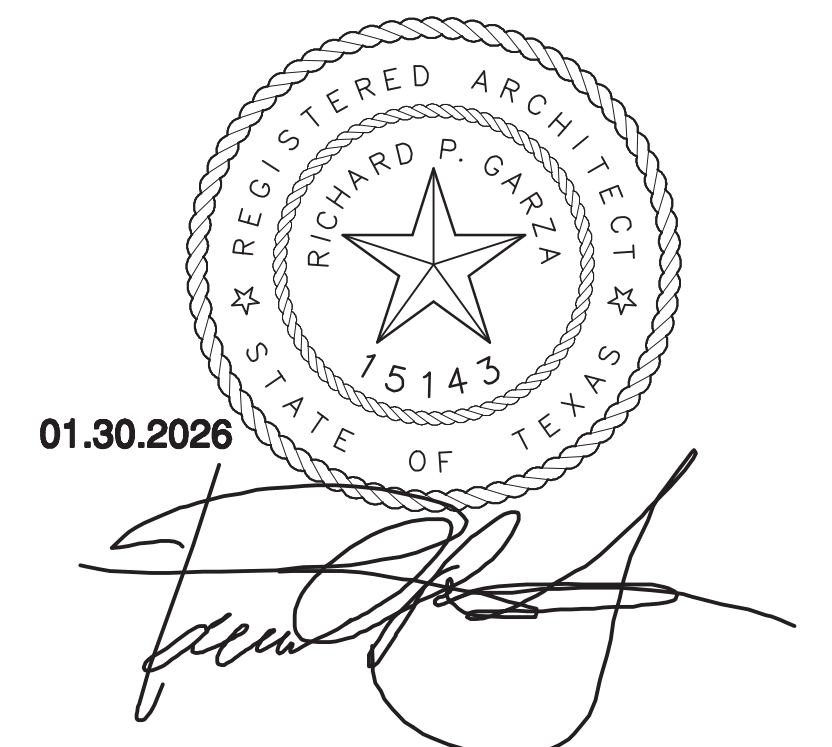

**OWNER:**

ABILENE HOUSING AUTHORITY  
4398 NORTH 7TH STREET  
ABILENE, TX 79603  
Deborah Hart  
Telephone: 325-676-6385 EXT. 6012  
Email: [deborah.hart@abileneha.org](mailto:deborah.hart@abileneha.org)

**ARCHITECT:**

RPGA Design Group, inc.  
1530 Rio Grande Ave.  
Fort Worth, Texas 76102  
Telephone: 817-332-9477  
Fax: 817-332-9487  
Principal: Rick Garza  
Email: [rickgarza@rpgaarchitects.com](mailto:rickgarza@rpgaarchitects.com)  
Project Manager: Dustin Higgins  
Email: [dhiggins@rpgaarchitects.com](mailto:dhiggins@rpgaarchitects.com)

ISSUE FOR CONSTRUCTION DATE:

01.30.2026



1530 Rio Grande Fort Worth, Texas 76102 817.332.9477 Fax 817.332.9487

[www.rpgaarchitects.com](http://www.rpgaarchitects.com)

[Instagram](https://www.instagram.com/rpgadesigngroupinc) [Facebook](https://www.facebook.com/rpgadesigngroupinc) @RPGADesignGroupInc

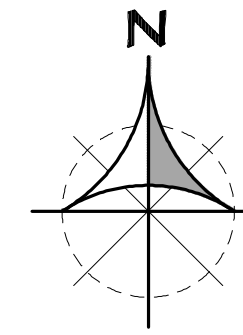
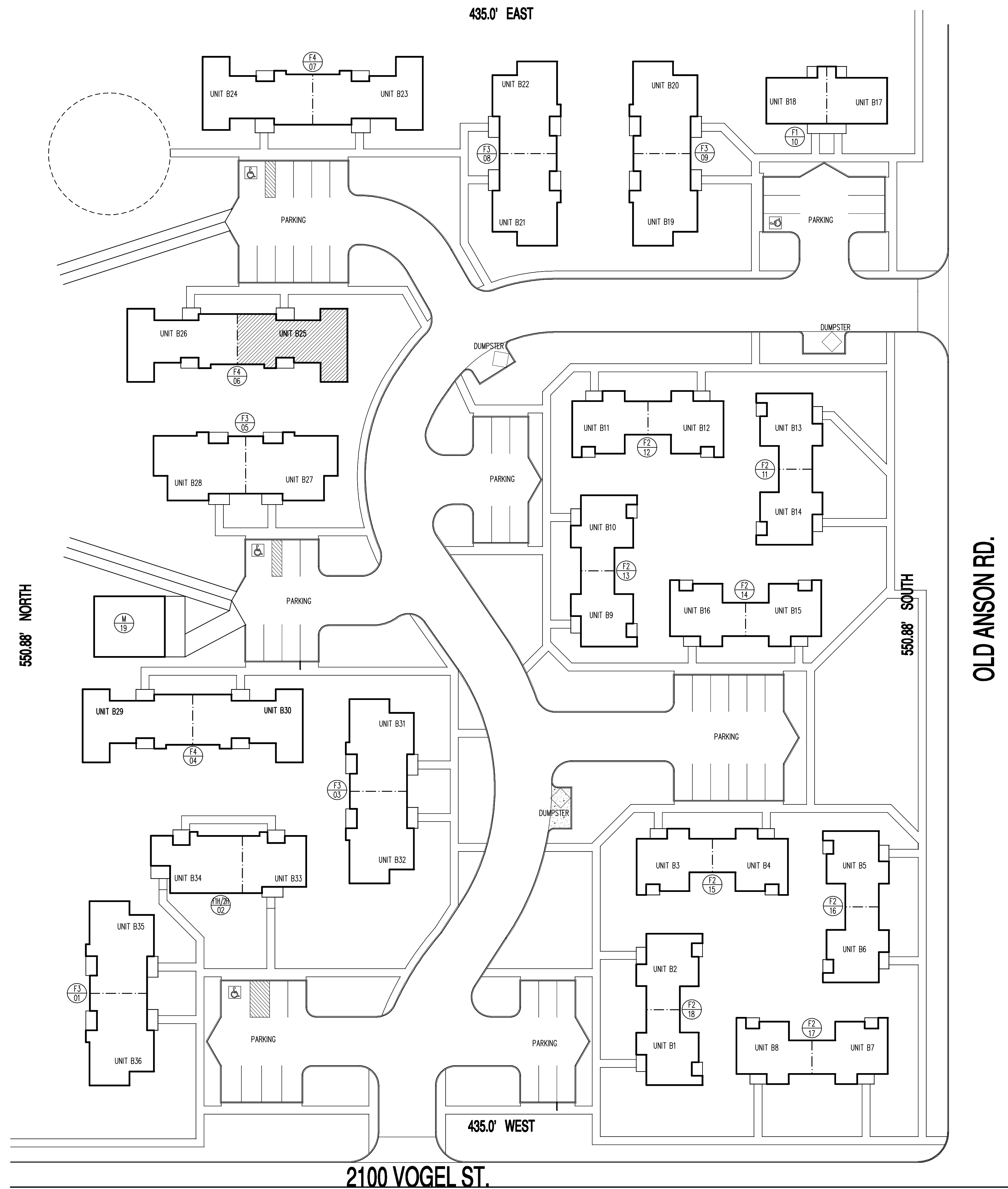

**01 SITE PLAN BRAILSFORD COMPLEX B**  
SCALE: 1"=30'-0"

DRAWN BY: K.R.G.  
 CHECKED BY: D.P.H.  
 DATE: 01.22.2026  
 ISSUED FOR PERMIT: 01.30.2026  
 ISSUE FOR PRICING: 01.30.2026  
 ISSUE FOR CONSTRUCTION: 01.30.2026  
 REVISIONS: \_\_\_\_\_

© 2026 by RPGA DESIGN GROUP, INC.  
 All rights reserved.  
 THE ARRANGEMENTS DEPICTED HEREIN ARE THE SOLE PROPERTY OF RPGA DESIGN GROUP, INC. AND MAY NOT BE REPRODUCED IN ANY FORM WITHOUT ITS WRITTEN PERMISSION.

**RPGA**  
 DESIGN GROUP, INC.  
 Architecture SpacePlanning Interiors

1530 Rio Grande Ave. Fort Worth, Texas 76102 817.332.9477 Fax 817.332.9487

**ABILENE HOUSING AUTHORITY**  
 UNIT RENOVATIONS AT  
 BRAILSFORD APARTMENTS "B"

ABILENE, TEXAS

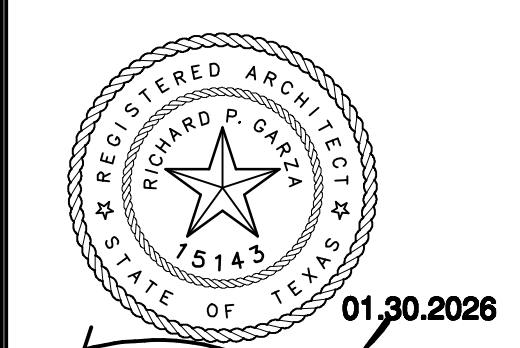

*Richard P. Carr*  
 01.30.2026

PROJECT NO. 2026-001  
 SHEET NO. A-1.01B

NOTE: 001  
ALL UNITS MUST HAVE LIGHT SWITCHES, OUTLETS & MECHANICAL CONTROLS IN ACCESSIBLE LOCATIONS THAT COMPLY WITH TAS, UFAS, ANSI & FAIR HOUSING GUIDELINES.

NOTE: 005  
REPLACE AND/OR INSTALL CEILING FANS AT ALL BEDROOMS AND LIVING ROOM SPACES.

NOTE: 002  
REPLACE ALL BATHROOM ACCESSORIES AND FIXTURES PER SPECIFICATIONS.

NOTE: 006  
REPLACE ALL LIGHT FIXTURES PER SPECIFICATIONS.

NOTE: 003  
REPLACE ALL APPLIANCES, PLUMBING FIXTURES, CABINETS, COUNTERTOPS AND DOOR HINGES/HANDLES PER SPECIFICATIONS.

NOTE: 007  
REPLACE ALL LIGHT SWITCHES, OUTLETS/PLUGS AND THEIR COVER PLATES PER SPECIFICATIONS.

NOTE: 004  
REPLACE ALL CEILINGS WITH NEW GYPSUM BD. IN THE ENTIRE APARTMENT UNIT. TAPE, BED AND PAINT.

NOTE: 008  
REPLACE ALL DOOR KNOBS PER SPECIFICATIONS.

\*\*\* VERIFY ALL DIMENSIONS ON SITE PRIOR TO INITIATE ANY WORK \*\*\*

LIGHTING LEGEND	
KEY	DESCRIPTION
	UF1 24"x13" LED SATIN NICKEL FLUSH MOUNT LIGHT
	UF2 12" LED SATIN NICKEL FLUSH MOUNT LIGHT
	UF3 24" LINEAR LIGHT LED BATH VANITY FIXTURE
	UF4 52" CEILING FAN WITH LIGHT
	UF5 6" CANNED LIGHT 10W LED RETROFIT BULB
	EX-V EXHAUST VENT WITH LIGHT

\*\* REFER SPECS FOR FIXTURE DETAILS \*\*  
\*\*\* GENERAL CONTRACTOR TO FIELD VERIFY EXISTING LOCATION USE EXISTING WIRE & SWITCH LOCATIONS \*\*\*

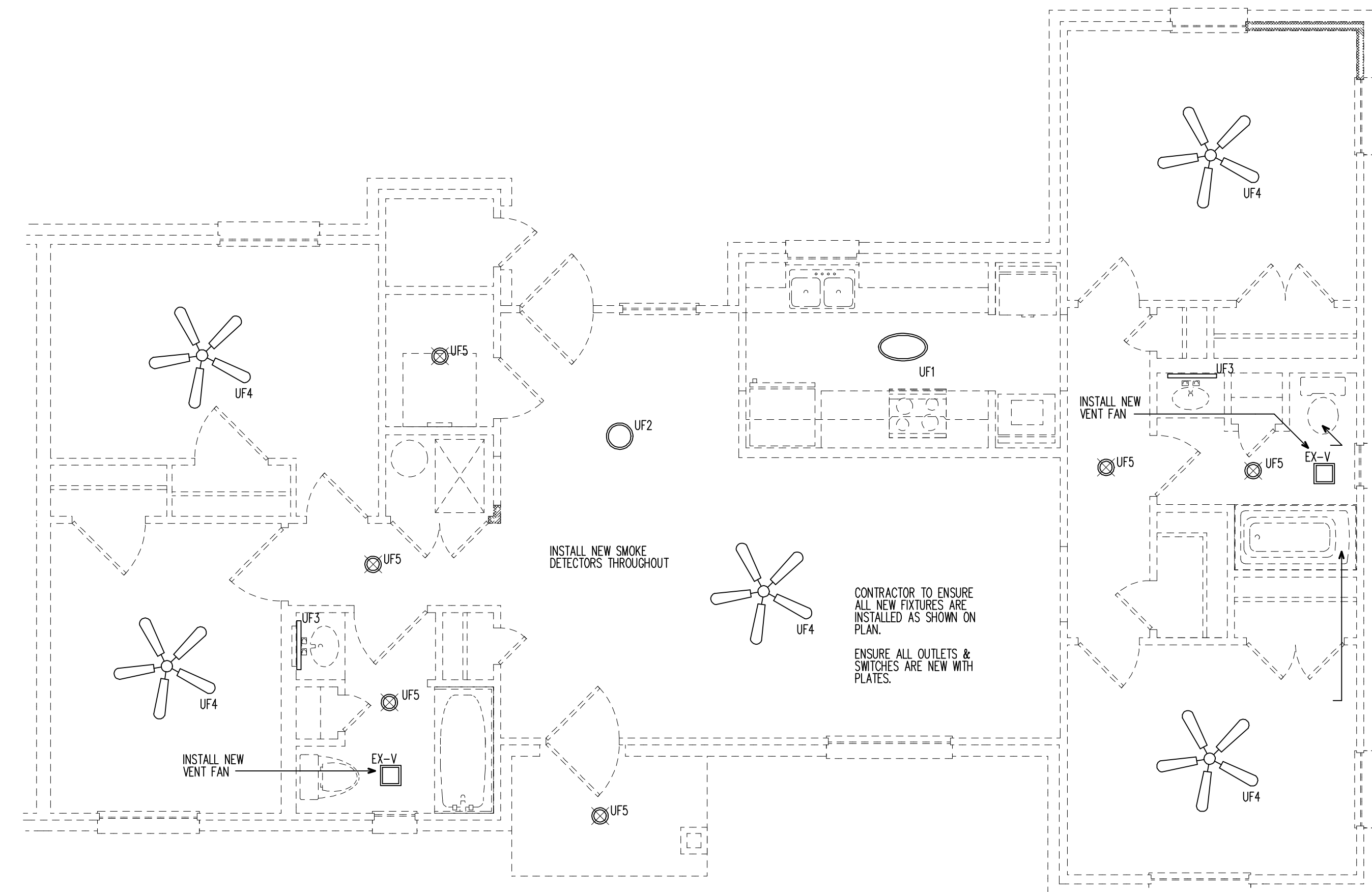

01 REFLECTED CEILING PLAN  
SCALE: 1/4" = 1'-0"

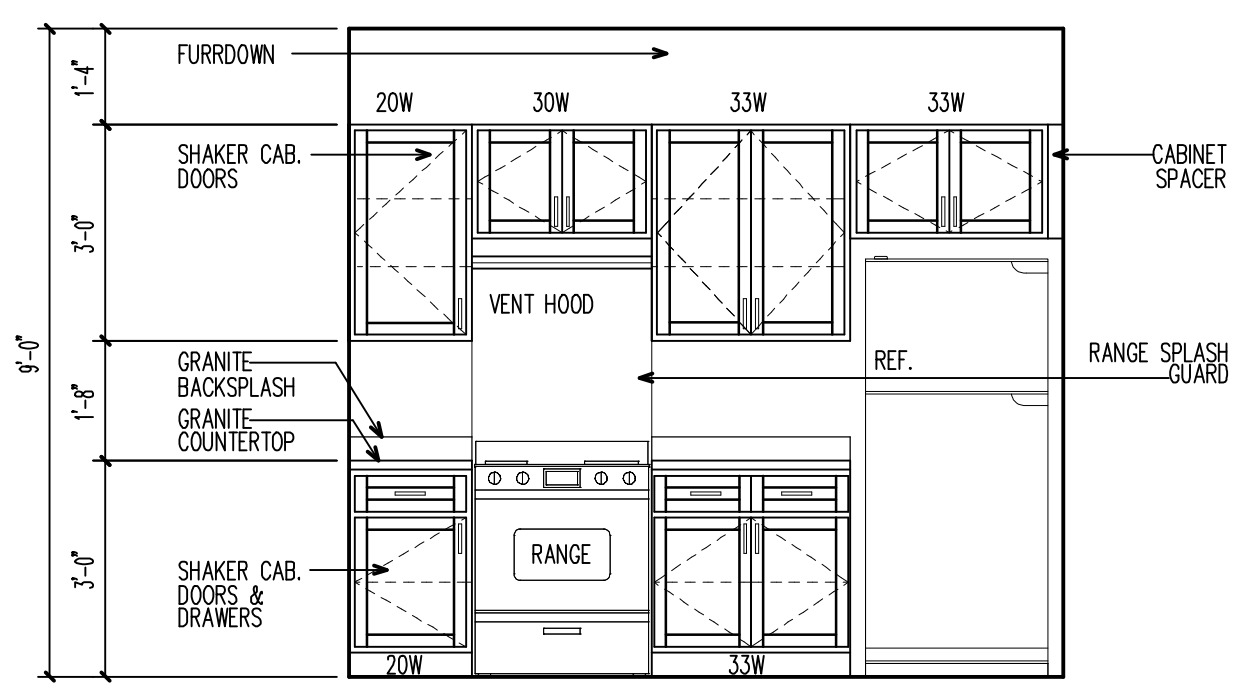
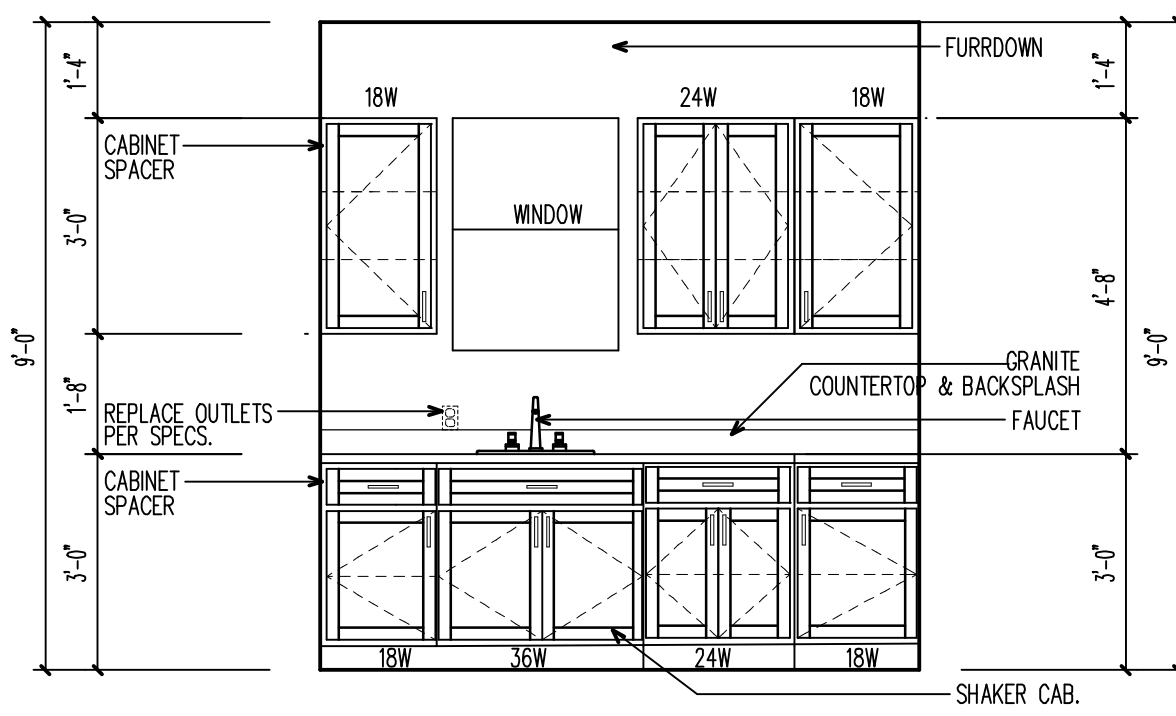

03 KITCHEN ELEV. @ SINK  
SCALE: 3/8" = 1'-0"

04 KITCHEN ELEV. @ RANGE/REF.  
SCALE: 3/8" = 1'-0"

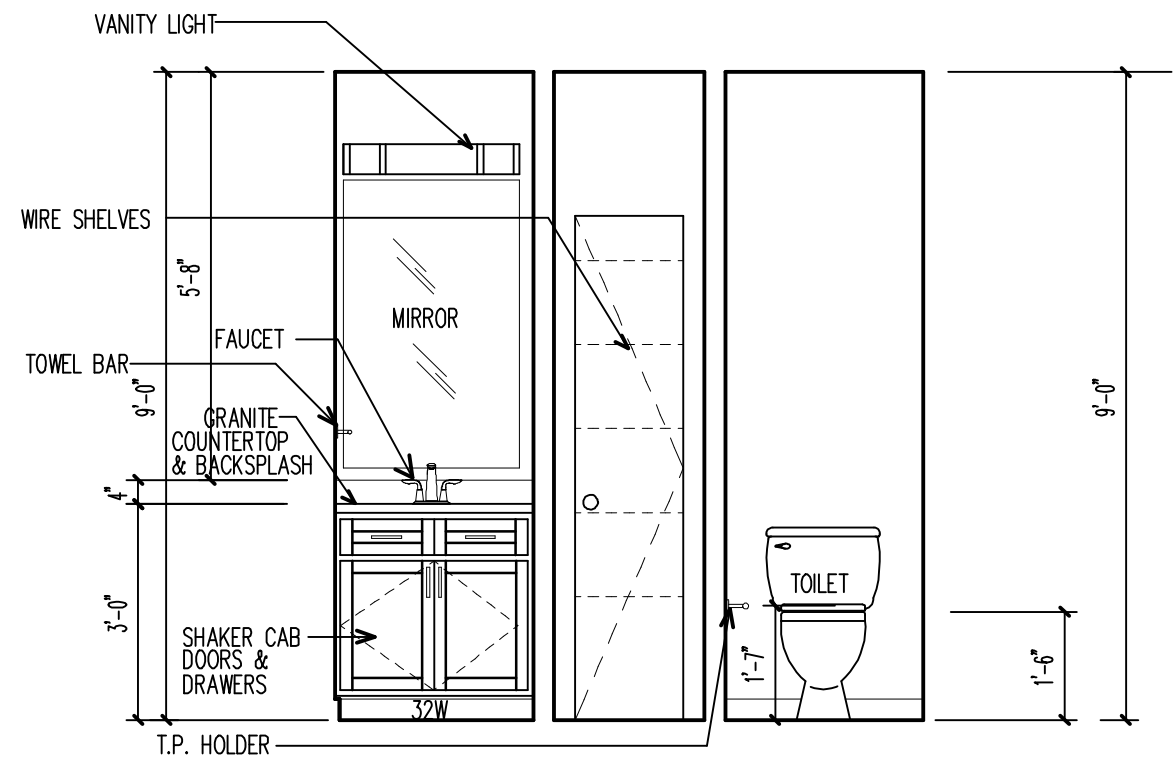

05 BATH ELEV. (TYP.)  
SCALE: 3/8" = 1'-0"

LEGEND  
WALLS TO REMAIN

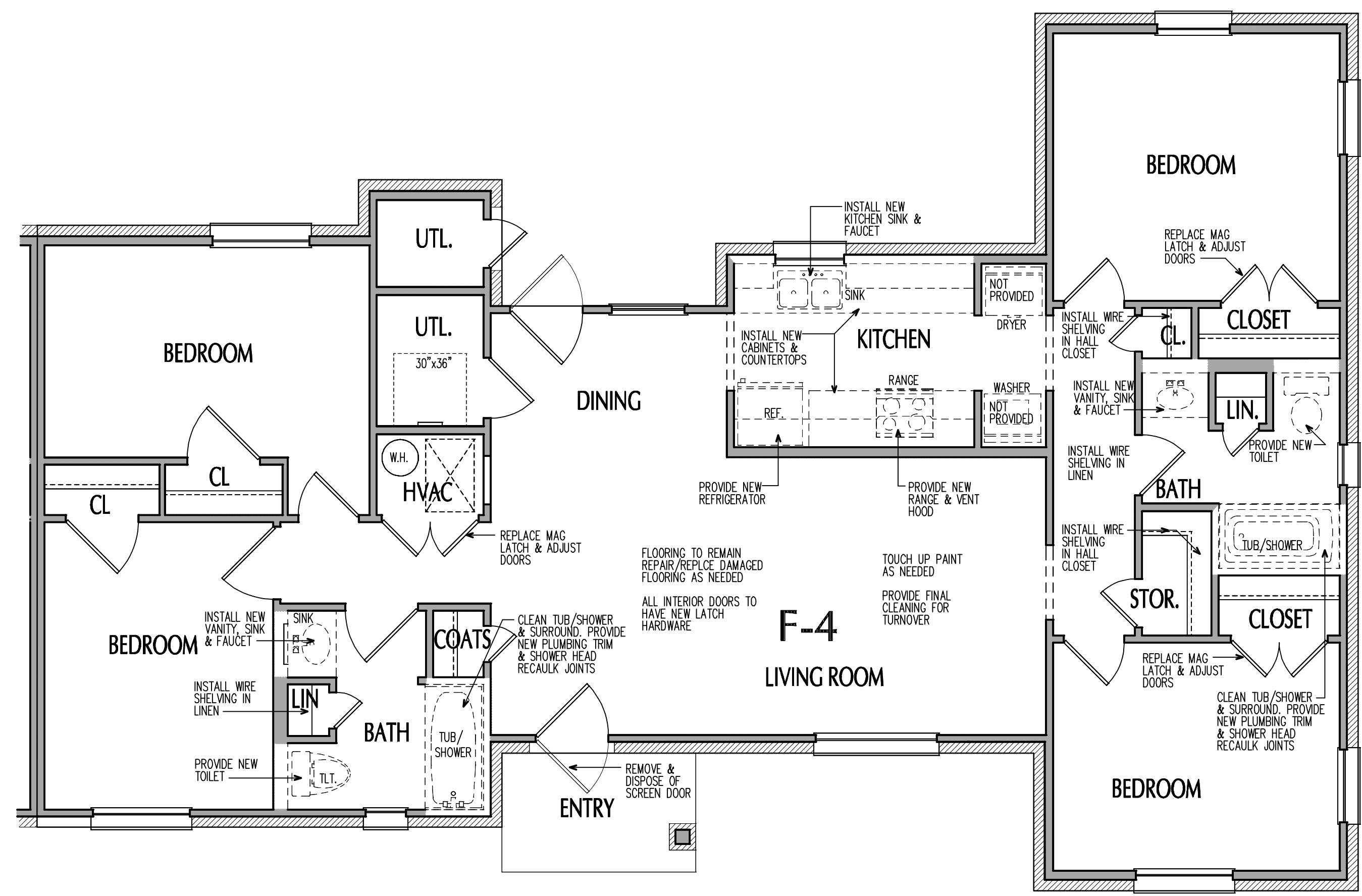

02 FLOOR PLAN "F4" - RENOVATION  
SCALE: 1/4" = 1'-0"

UNIT PLAN

DRAWN BY: K.R.G.  
CHECKED BY: R.P.G.  
DATE: 01.22.2026  
ISSUED FOR PERMIT: 01.30.2026  
ISSUE FOR PRICING: 01.30.2026  
ISSUE FOR CONSTRUCTION: 01.30.2026  
REVISIONS:

© 2026 by RPGA DESIGN GROUP, INC. All rights reserved.

THE ARRANGEMENTS DEPICTED HEREIN ARE THE SOLE PROPERTY OF RPGA DESIGN GROUP, INC. AND MAY NOT BE REPRODUCED IN ANY FORM WITHOUT ITS WRITTEN PERMISSION.

**RPGA DESIGN GROUP, INC.**  
Architecture SpacePlanning Interiors  
1530 Rio Grande Ave. Fort Worth, Texas 76102  
817.332.9477  
www.rpgaarchitects.com  
@RPGADesignGroupinc

ABILENE HOUSING AUTHORITY  
UNIT RENOVATIONS AT  
BRAILSFORD APARTMENTS "B"  
ABILENE, TEXAS

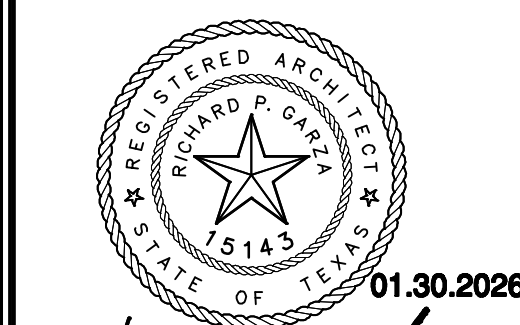

01.30.2026

PROJECT NO.  
2026-001

SHEET NO.  
A-2.01B

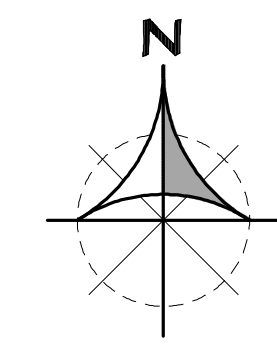

DRAWN BY: K.R.G.  
 CHECKED BY: D.P.H.  
 DATE: 01.22.2026  
 ISSUED FOR PERMIT: 01.30.2026  
 ISSUE FOR PRICING: 01.30.2026  
 ISSUE FOR CONSTRUCTION: 01.30.2026  
 REVISIONS:

© 2026 by RPGA DESIGN GROUP, INC.  
 All rights reserved.

THE ARRANGEMENTS DEPICTED HEREIN ARE THE  
 SOLE PROPERTY OF RPGA DESIGN GROUP, INC.  
 AND MAY NOT BE REPRODUCED IN ANY FORM  
 WITHOUT ITS WRITTEN PERMISSION.

**RPGA**  
 DESIGN GROUP, INC.  
 Architecture SpacePlanning Interiors

1530 Rio Grande Ave. Fort Worth, Texas 76102 817.332.9477 Fax 817.332.9487

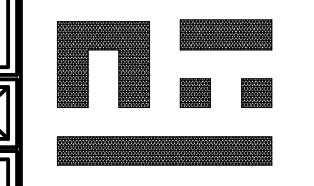

ABILENE HOUSING AUTHORITY  
 UNIT RENOVATIONS AT  
 BRAILSFORD APARTMENTS "D"

ABILENE, TEXAS

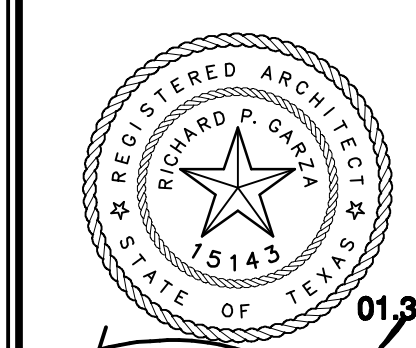

01.30.2026  
*Richard P. Garza*

PROJECT NO.  
 2026-001  
 SHEET NO.  
 A-1.01D

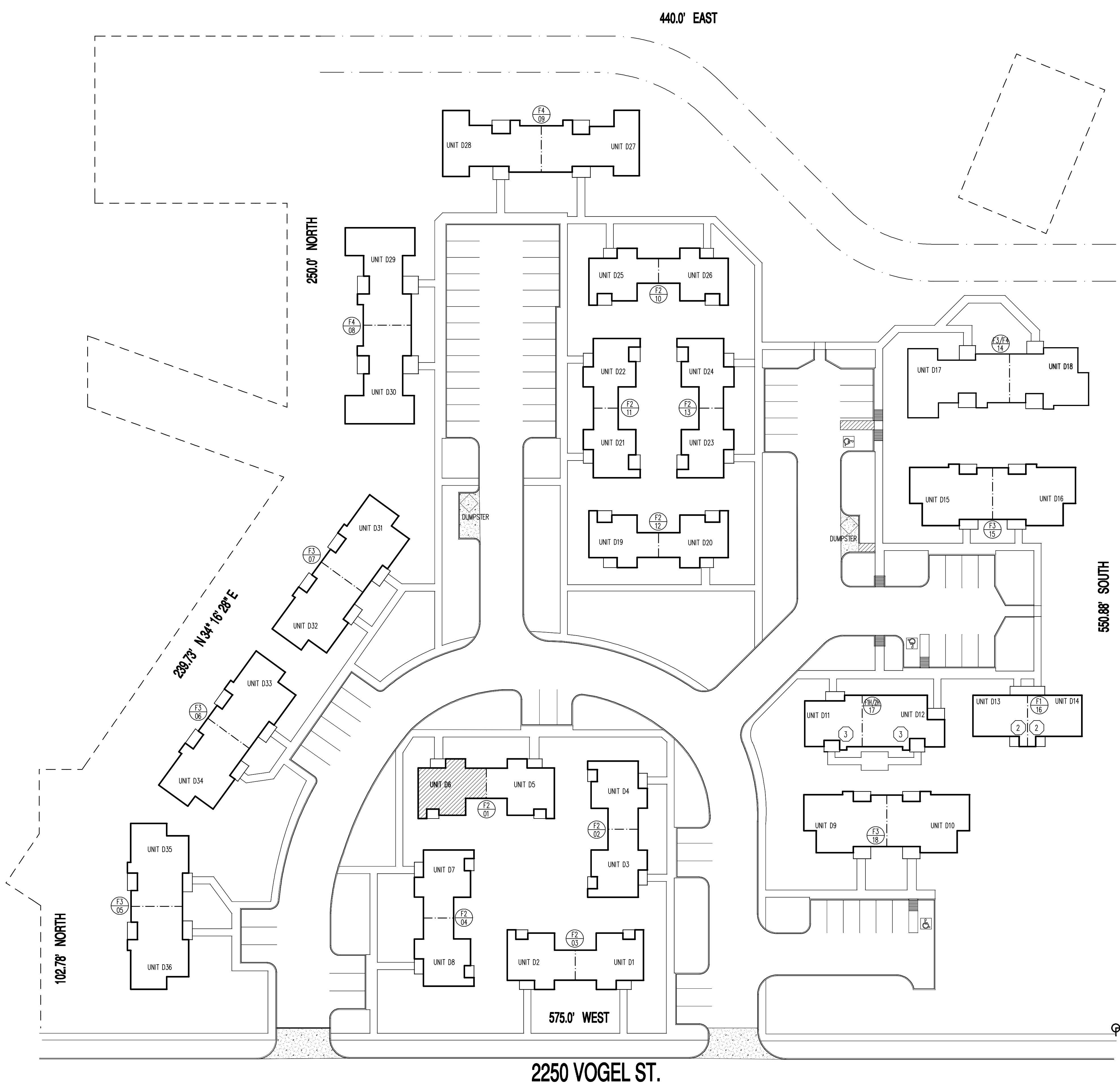

- NOTE: 001  
ALL UNITS MUST HAVE LIGHT SWITCHES, OUTLETS & MECHANICAL CONTROLS IN ACCESSIBLE LOCATIONS THAT COMPLY WITH TAS, UFAS, ANSI & FAIR HOUSING GUIDELINES.
- NOTE: 002  
REPLACE ALL BATHROOM ACCESSORIES AND FIXTURES PER SPECIFICATIONS.
- NOTE: 003  
REPLACE ALL APPLIANCES, PLUMBING FIXTURES, CABINETS, COUNTERTOPS AND DOOR HINGES/HANDLES PER SPECIFICATIONS.
- NOTE: 004  
REPLACE AND/OR INSTALL CEILING FANS AT ALL BEDROOMS AND LIVING ROOM SPACES.
- NOTE: 005  
REPLACE ALL LIGHT FIXTURES PER SPECIFICATIONS.
- NOTE: 006  
REPLACE ALL LIGHT SWITCHES, OUTLETS/PLUGS AND THEIR COVER PLATES PER SPECIFICATIONS.
- NOTE: 007  
REPLACE ALL DOOR KNOBS PER SPECIFICATIONS.

\*\*\* VERIFY ALL DIMENSIONS ON SITE PRIOR TO INITIATE ANY WORK \*\*\*

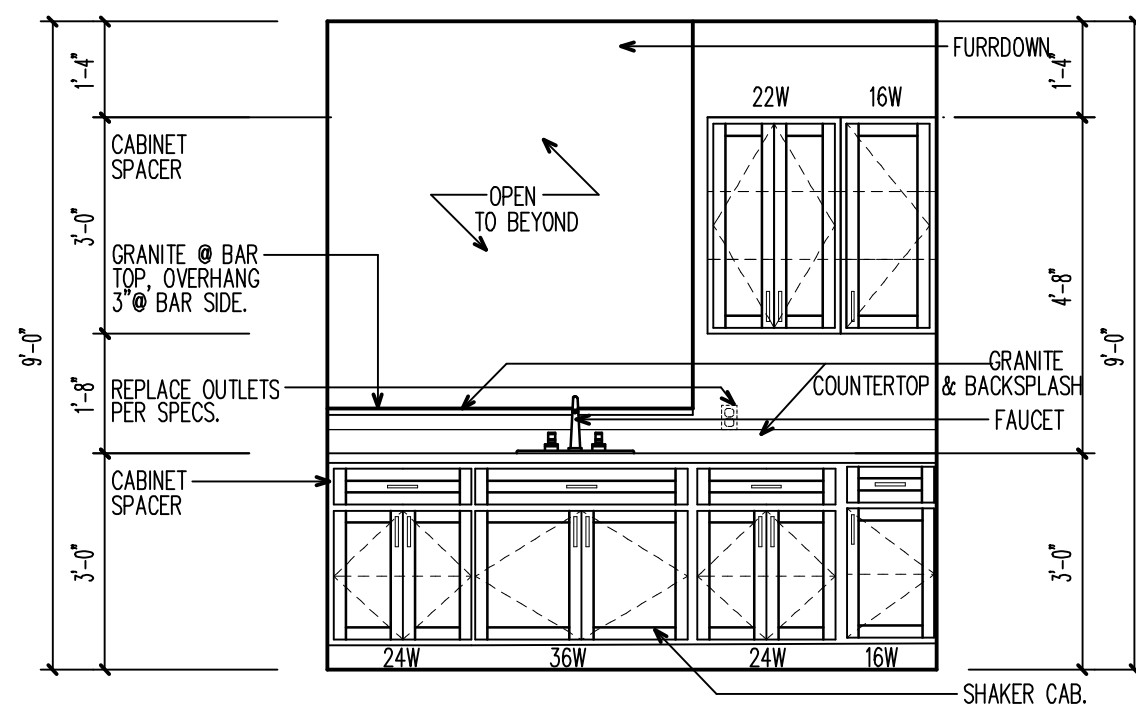

03 **KITCHEN ELEV. @ SINK**  
SCALE: 3/8" = 1'-0"

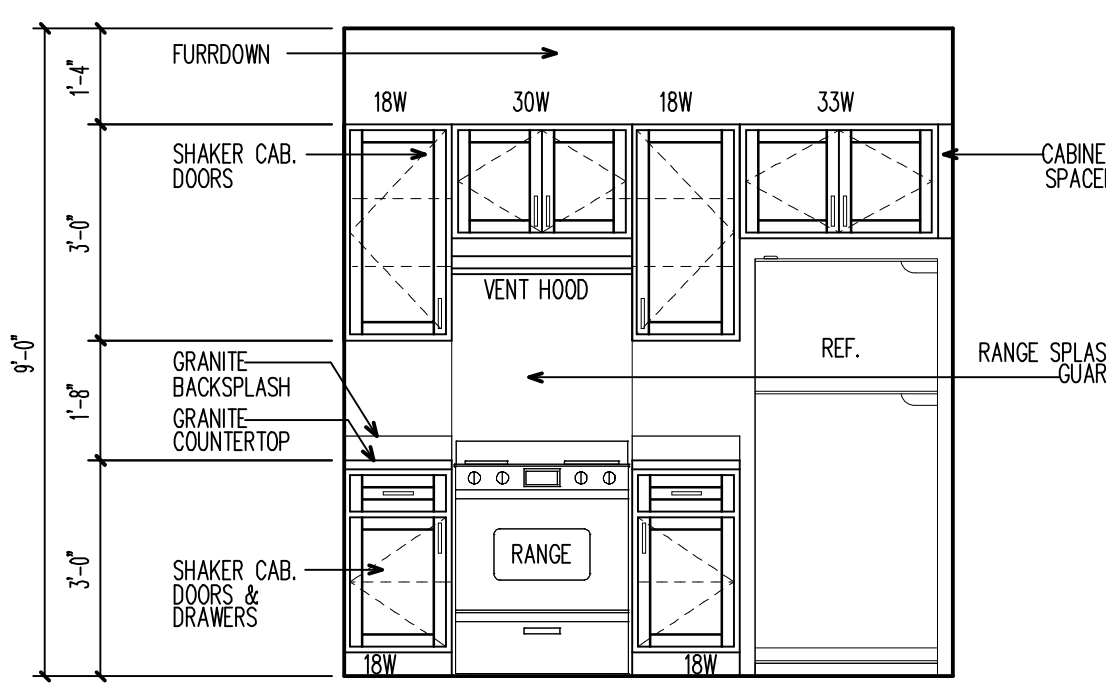

04 **KITCHEN ELEV. @ RANGE/REF.**  
SCALE: 3/8" = 1'-0"

LIGHTING LEGEND	
UF1	24"x13" LED SATIN NICKEL FLUSH MOUNT LIGHT
UF2	12" LED SATIN NICKEL FLUSH MOUNT LIGHT
UF3	24" LINEAR LIGHT LED BATH VANITY FIXTURE
UF4	52" CEILING FAN WITH LIGHT
UF5	6" CANNED LIGHT TOW LED RETROFIT BULB
EX-V	EXHAUST VENT WITH LIGHT

\*\*\* REFER SPECS FOR FIXTURE DETAILS \*\*\*  
\*\*\* GENERAL CONTRACTOR TO FIELD VERIFY EXISTING LOCATION USE EXISTING WIRE & SWITCH LOCATIONS \*\*\*

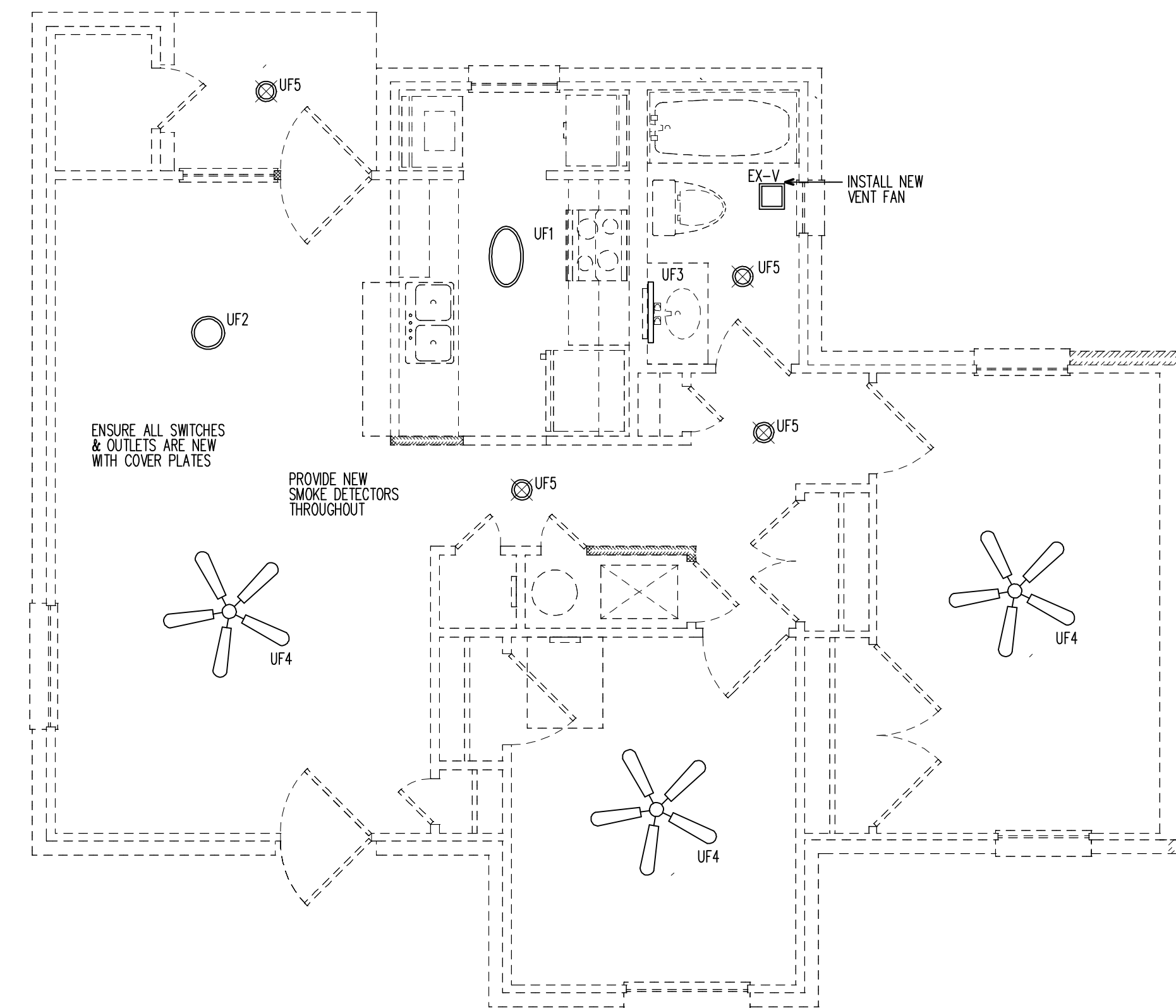

01 **REFLECTED CEILING PLAN**  
SCALE: 1/4" = 1'-0" UNIT D6

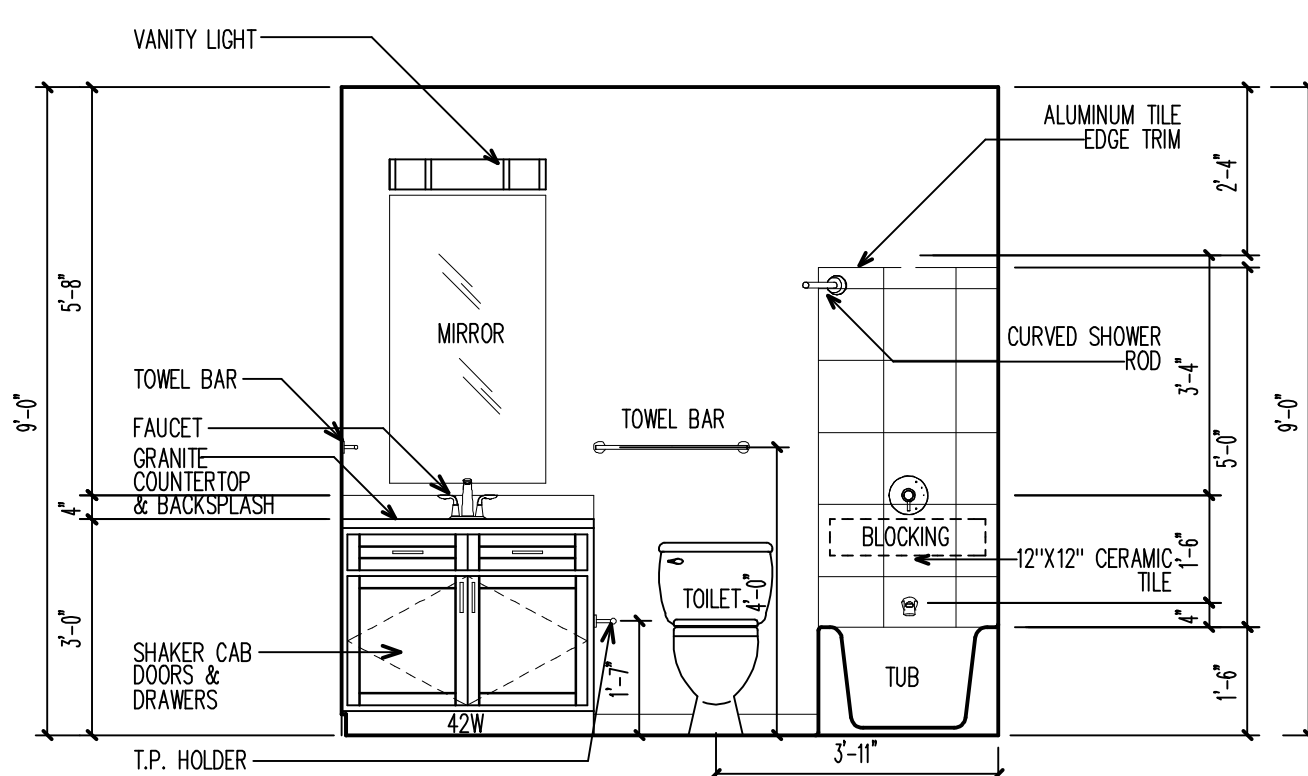

05 **BATH ELEVATION**  
SCALE: 3/8" = 1'-0"

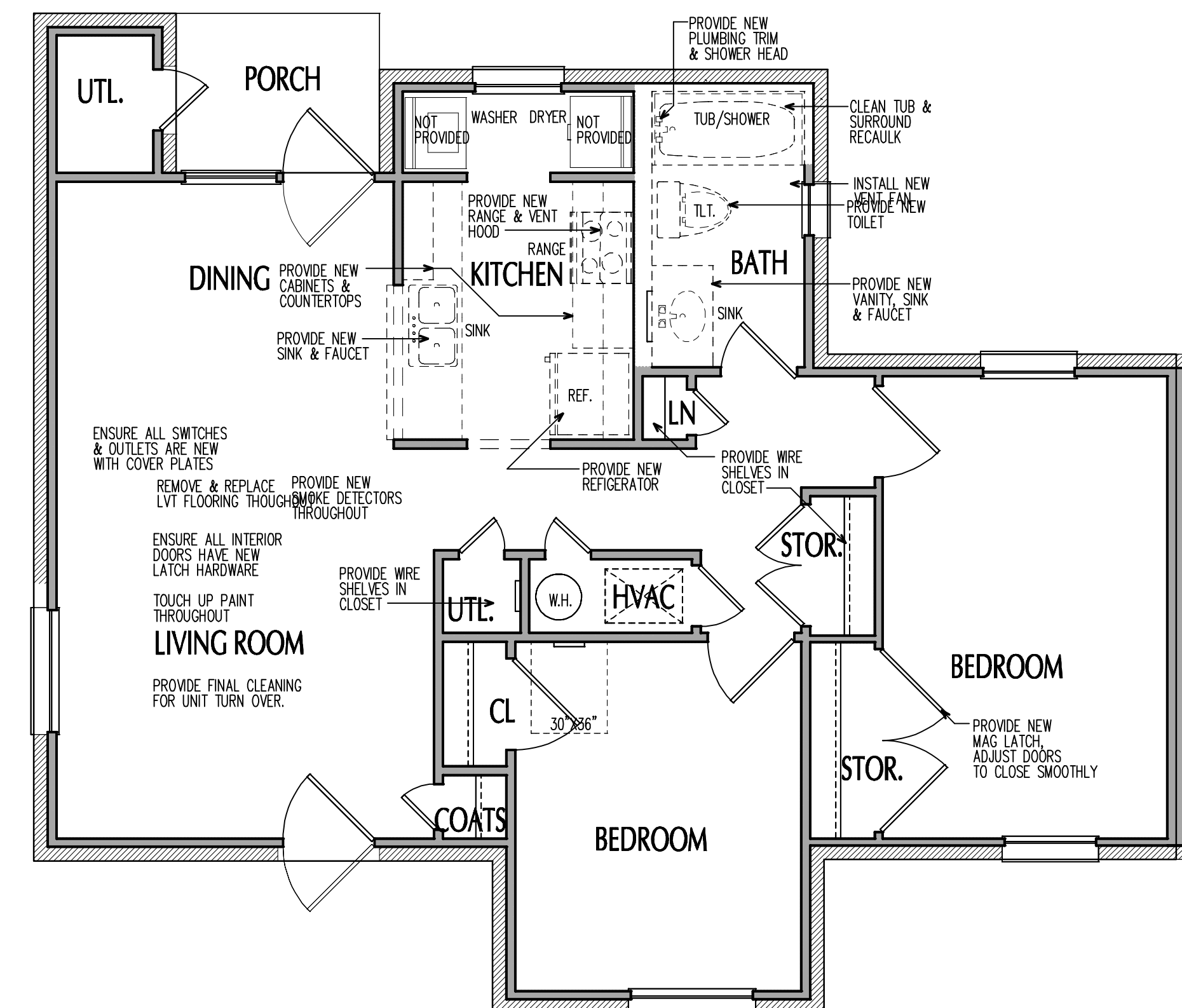
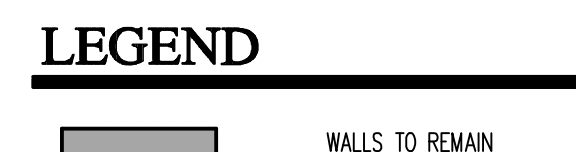

02 **FLOOR PLAN "F2" - RENOVATION**  
SCALE: 1/4" = 1'-0" UNIT D6

DRAWN BY: **K.R.G.**  
CHECKED BY: **R.P.G.**  
DATE: **01.20.2026**  
ISSUED FOR PERMIT: **01.30.2026**  
ISSUE FOR PRICING: **01.30.2026**  
ISSUE FOR CONSTRUCTION: **01.30.2026**  
REVISIONS:

© 2026 by RPGA DESIGN GROUP, INC. All rights reserved.

THE ARRANGEMENTS DEPICTED HEREIN ARE THE SOLE PROPERTY OF RPGA DESIGN GROUP, INC. AND MAY NOT BE REPRODUCED IN ANY FORM WITHOUT ITS WRITTEN PERMISSION.

**RPGA DESIGN GROUP, INC.**  
Architecture Space Planning Interiors  
1500 Rho Grande Ave. Fort Worth, Texas 76102 817.332.9477 Fax 817.332.9487  
www.rpgaarchitects.com @RPGADesignGroupInc

ABILENE HOUSING AUTHORITY  
UNIT RENOVATIONS AT  
BRAILSFORD APARTMENTS "D"

TEXAS

ABILENE,



01.30.2026

PROJECT NO.  
2026-001

SHEET NO.  
**A-2.01D**

UNIT PLAN

# SITE PLAN - RIVIERA APARTMENTS

SCALE: 1"=20'-0"

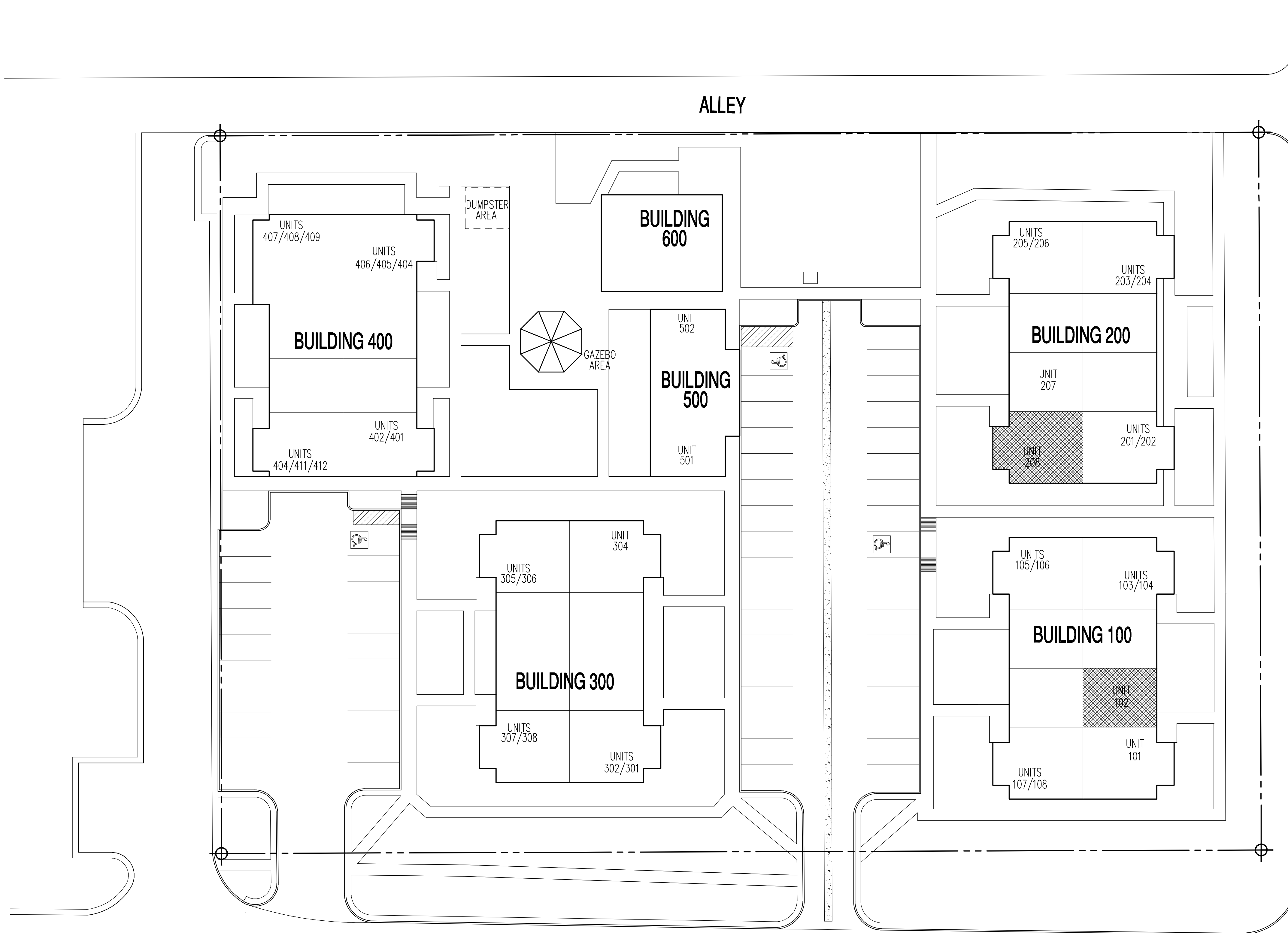

MOCKINGBIRD LANE

ALLEY

NORTH 6TH STREET

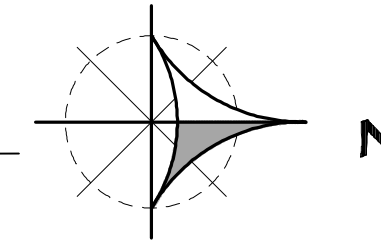

## LEGEND

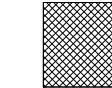

RENOVATION UNIT LOCATIONS - 102 & 208

DRAWN BY: K.R.G.  
 CHECKED BY: D.P.H.  
 DATE: 01.20.2026  
 ISSUED FOR PERMIT: 01.30.2026  
 ISSUE FOR PRICING: 01.30.2026  
 ISSUE FOR CONSTRUCTION: 01.30.2026  
 REVISIONS: \_\_\_\_\_

© 2026 by RPGA DESIGN GROUP, INC.  
 All rights reserved.

THE ARRANGEMENTS DEPICTED HEREIN ARE THE  
 SOLE PROPERTY OF RPGA DESIGN GROUP, INC.  
 AND MAY NOT BE REPRODUCED IN ANY FORM  
 WITHOUT ITS WRITTEN PERMISSION.

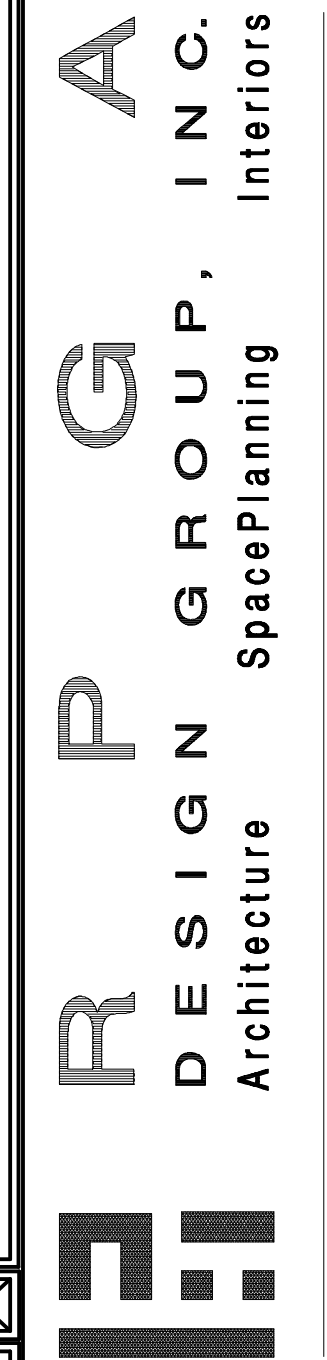

1530 Rio Grande Ave. Fort Worth, Texas 76102 817.332.9477 Fax 817.332.9487

ABILENE HOUSING AUTHORITY  
 UNIT RENOVATIONS AT  
 RIVIERA APARTMENTS

TEXAS

ABILENE,

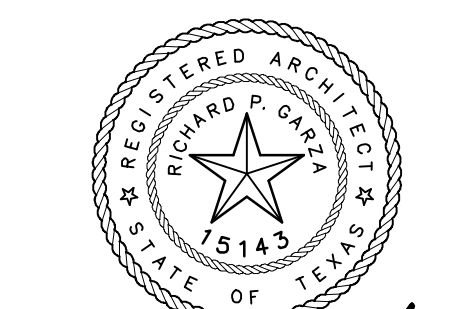

*Richard P. Gray*  
 01.30.2026

PROJECT NO.  
 2026-001

SHEET NO.  
 A-1.01R



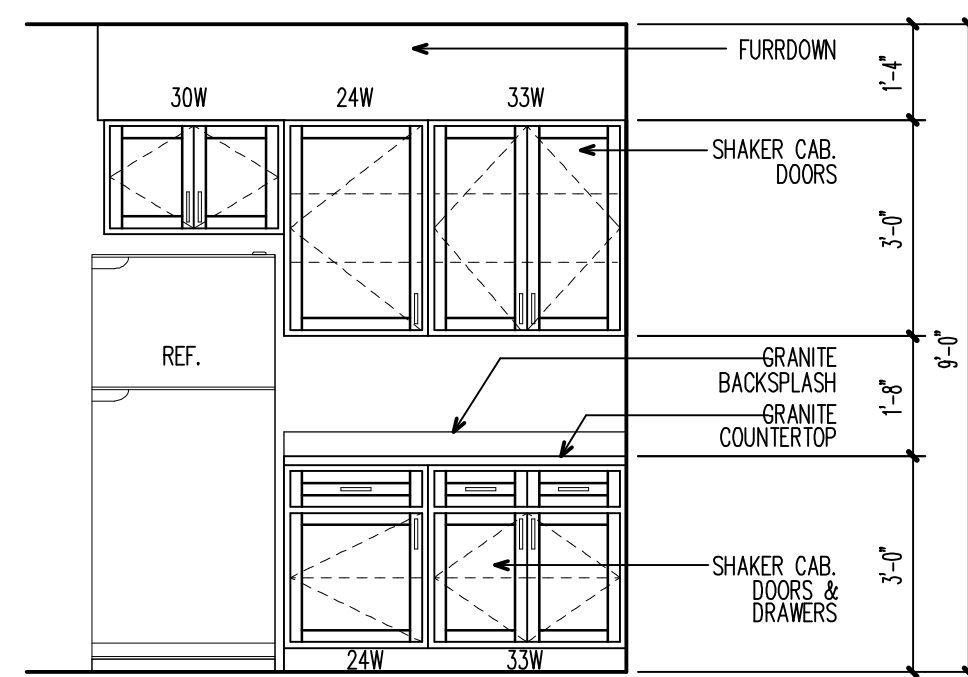

**07 KITCHEN @ REFR.**  
SCALE: 3/8" = 1'-0"

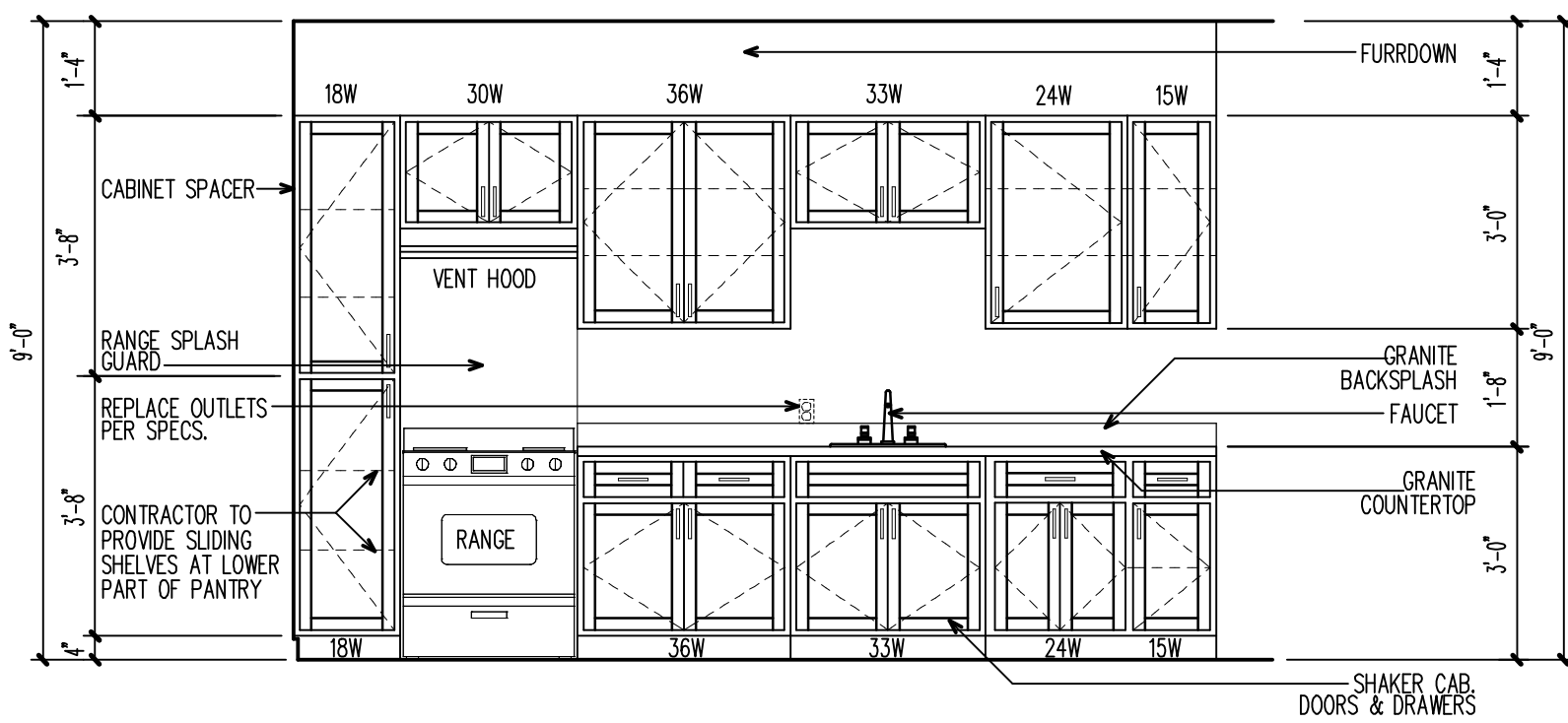

**06 KITCHEN @ SINK/RANGE**  
SCALE: 3/8" = 1'-0"

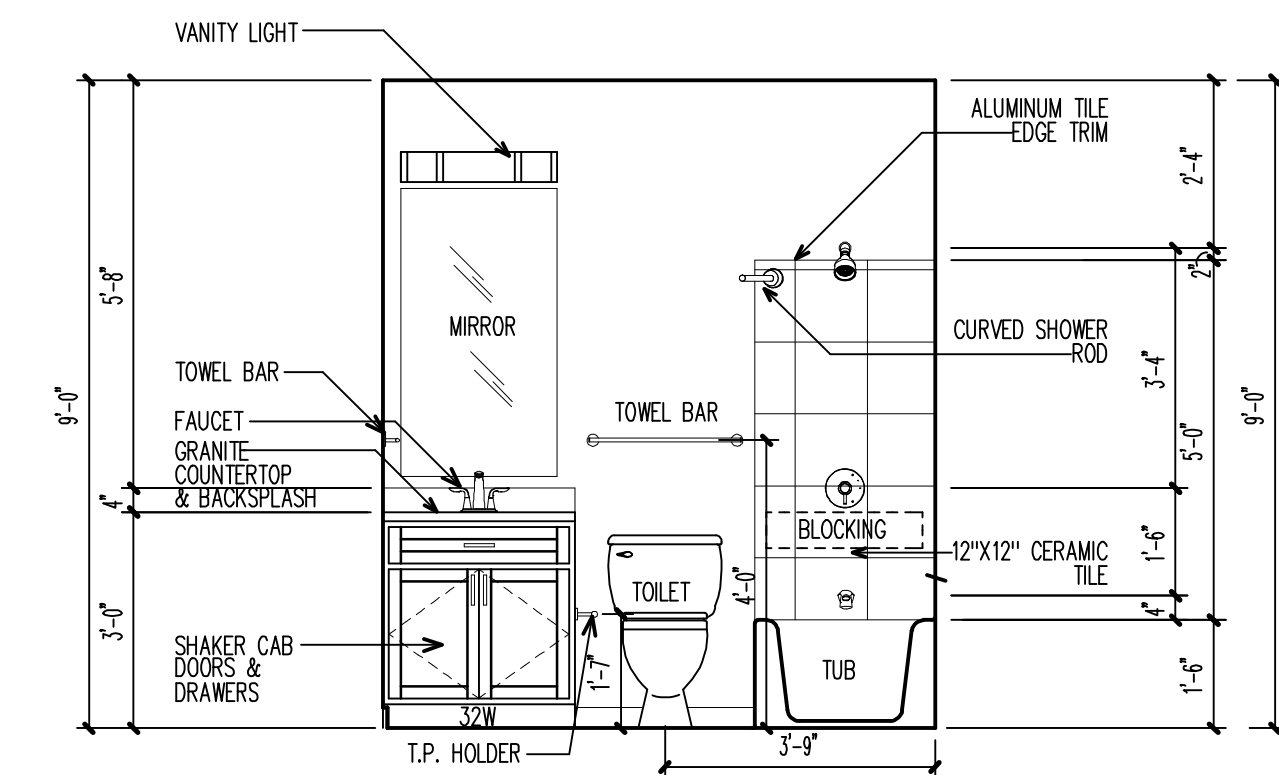

**05 BATHS (TYP.)**  
SCALE: 3/8" = 1'-0"

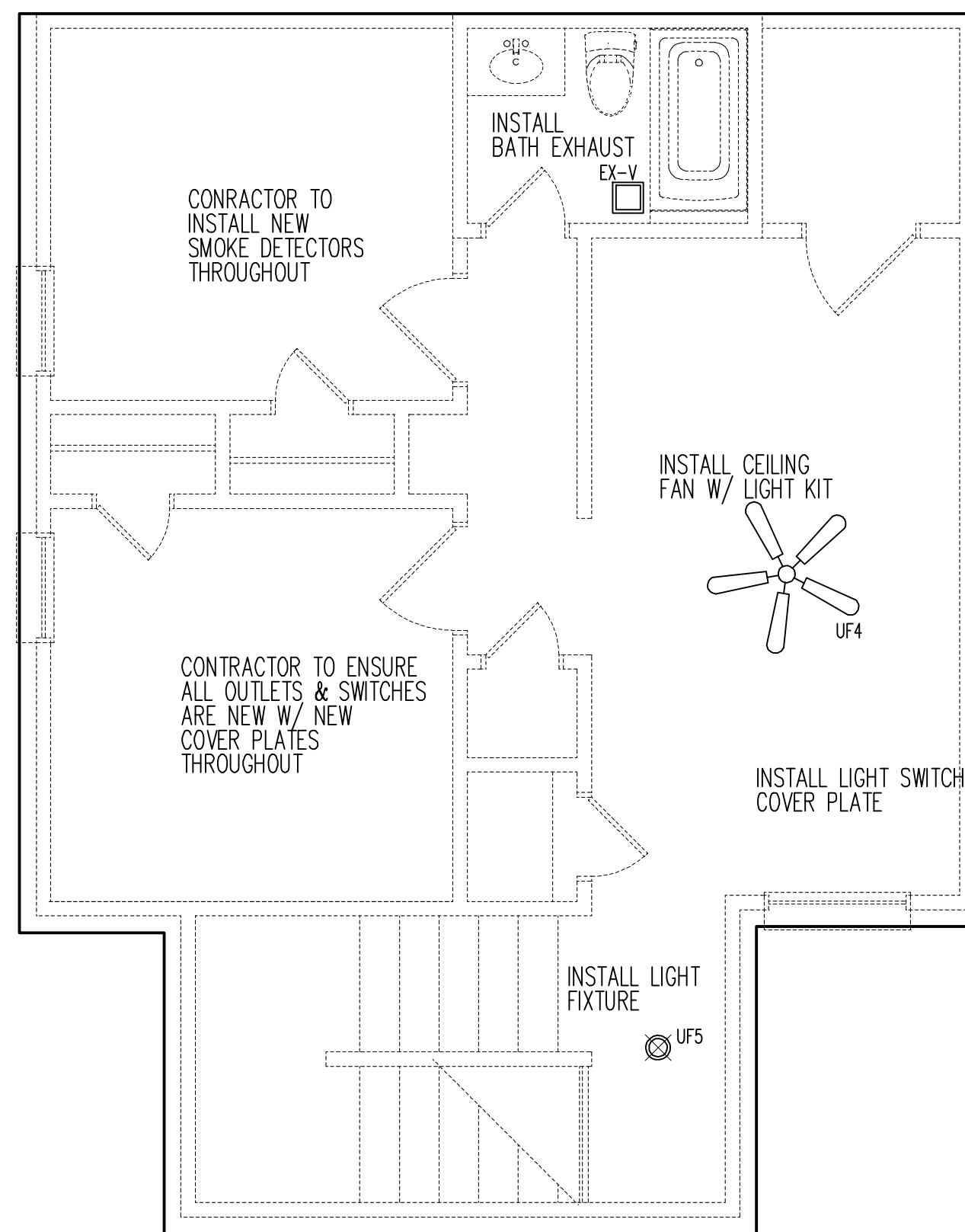

**04 UNIT 208 - 2ND.FL. RCP**  
SCALE: 1/4" = 1'-0" 4-BEDROOM TYPE

- NOTE: 001 ALL UNITS MUST HAVE LIGHT SWITCHES, OUTLETS & MECHANICAL CONTROLS IN ACCESSIBLE LOCATIONS THAT COMPLY WITH TAS, UFAS, ANSI & FAIR HOUSING GUIDELINES.
- NOTE: 002 REPLACE ALL BATHROOM ACCESSORIES AND FIXTURES PER SPECIFICATIONS.
- NOTE: 003 REPLACE ALL APPLIANCES, PLUMBING FIXTURES, CABINETS, COUNTERTOPS AND DOOR HINGES/HANDLES PER SPECIFICATIONS.
- NOTE: 004 REPLACE AND/OR INSTALL CEILING FANS AT ALL BEDROOMS AND LIVING ROOM SPACES.
- NOTE: 005 REPLACE ALL LIGHT FIXTURES PER SPECIFICATIONS.
- NOTE: 006 REPLACE ALL LIGHT SWITCHES, OUTLETS/PLUGS AND THEIR COVER PLATES PER SPECIFICATIONS.
- NOTE: 007 REPLACE ALL DOOR KNOBS PER SPECIFICATIONS.

\*\*\* VERIFY ALL DIMENSIONS ON SITE PRIOR TO INITIATE ANY WORK \*\*\*

LIGHTING LEGEND	
KEY	DESCRIPTION
	UF1 FLUSH MOUNT LIGHT
	UF2 12" FLUSH MOUNT LIGHT
	UF3 BATH VANITY FIXTURE
	UF4 52" CEILING FAN WITH LIGHT
	UF5 6" CANNED LIGHT
	EX-V EXHAUST VENT WITH LIGHT

\*\*\* REFER SPECS FOR FIXTURE DETAILS \*\*\*  
\*\*\* GENERAL CONTRACTOR TO FIELD VERIFY EXISTING LOCATION USE EXISTING WIRE & SWITCH LOCATIONS \*\*\*

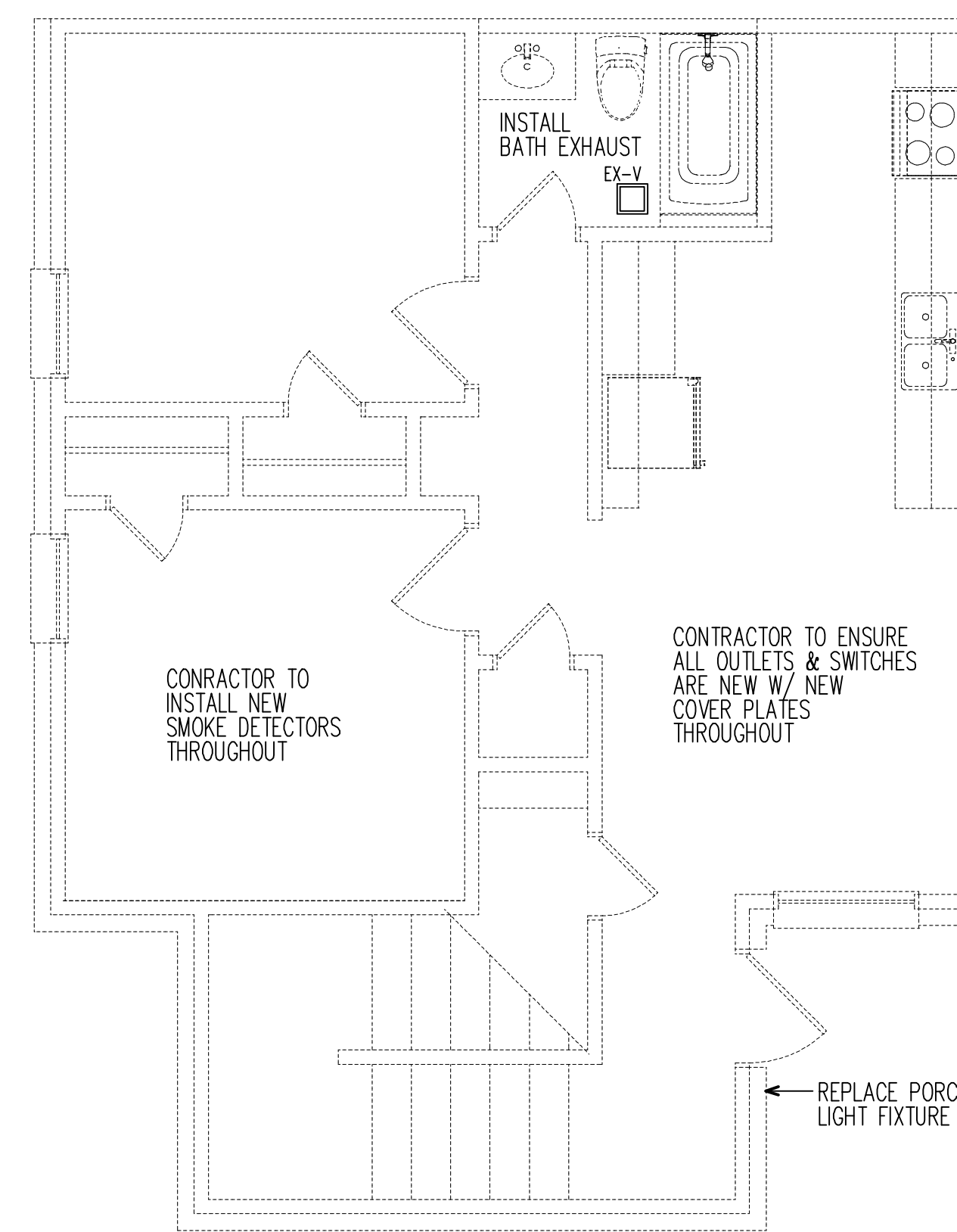

**03 UNIT 208 - 1ST.FL. RCP**  
SCALE: 1/4" = 1'-0" 4-BEDROOM TYPE

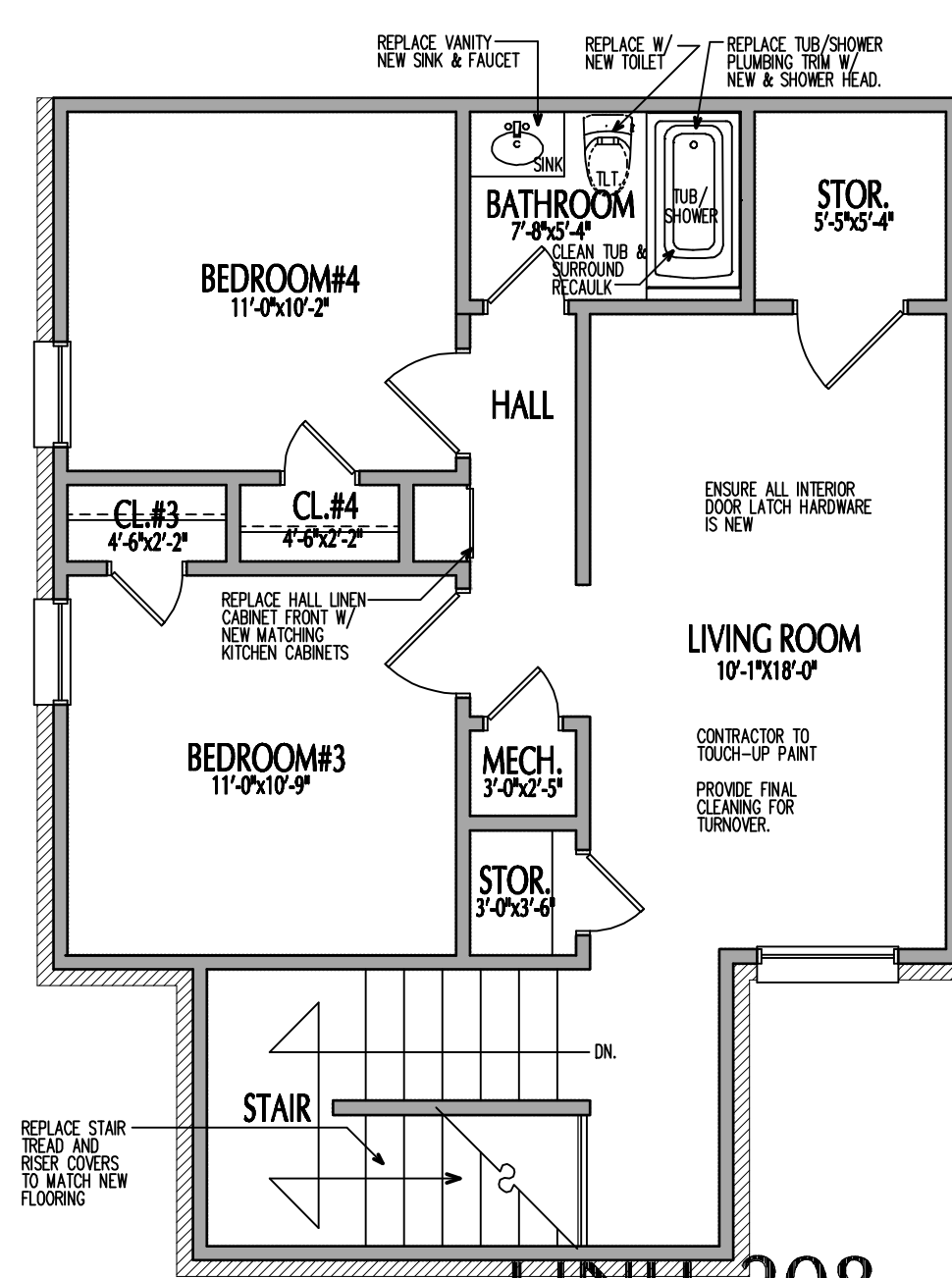

**02 UNIT 208 - SECOND FLOOR PLAN**  
SCALE: 1/4" = 1'-0" 4-BEDROOM TYPE

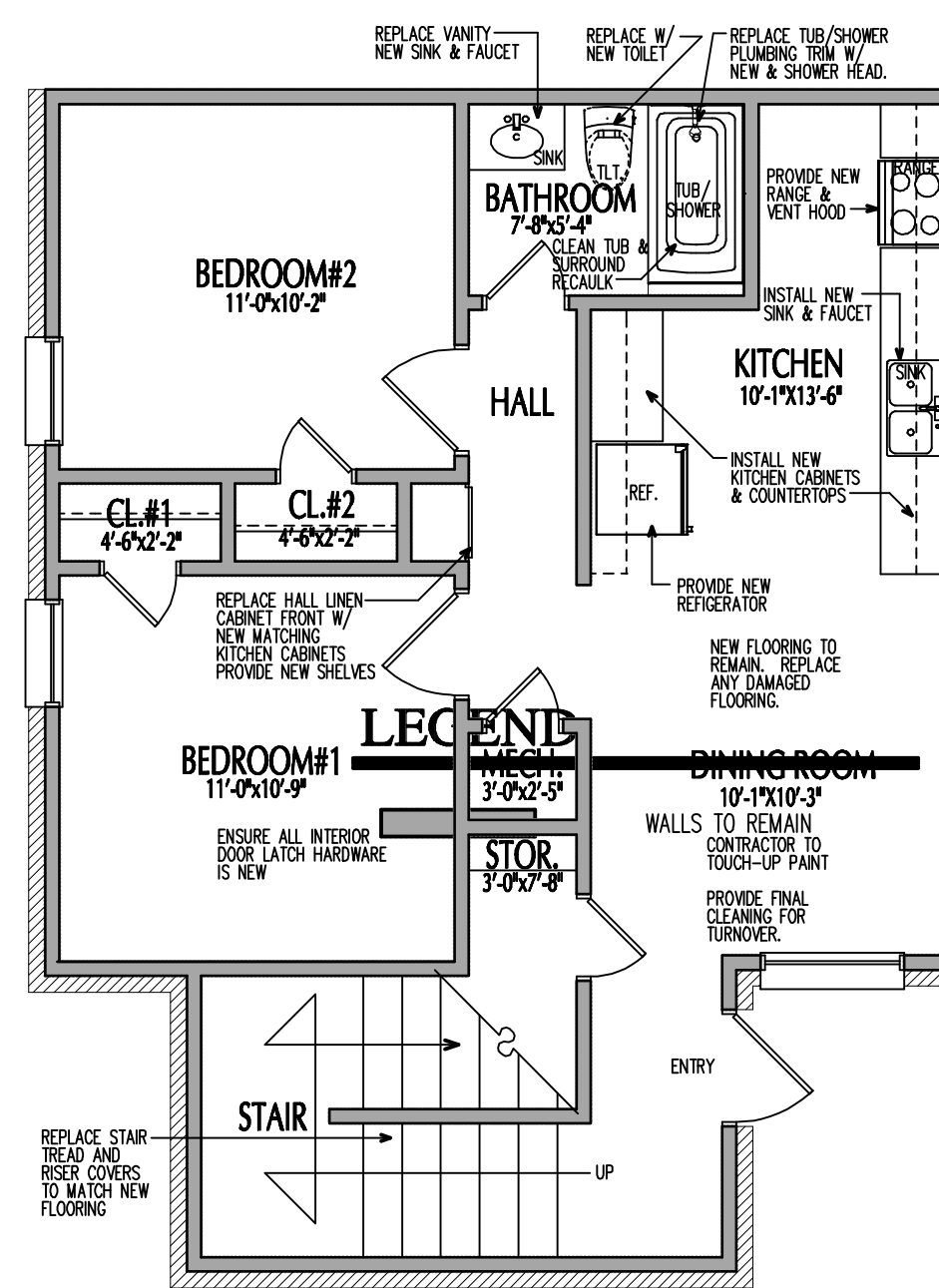

**01 UNIT 208 - FIRST FLOOR PLAN**  
SCALE: 1/4" = 1'-0" 4-BEDROOM TYPE

DRAWN BY: **F.S.G., K.R.G.**  
CHECKED BY: **R.P.G.**  
DATE: **01.20.2026**  
ISSUED FOR PERMIT: **01.30.2026**  
ISSUE FOR PRICING: **01.30.2026**  
ISSUE FOR CONSTRUCTION: **01.30.2026**  
REVISIONS:

© 2026 by RPGA DESIGN GROUP, INC. All rights reserved.

THE ARRANGEMENTS DEPICTED HEREIN ARE THE SOLE PROPERTY OF: RPGA DESIGN GROUP, INC. AND MAY NOT BE REPRODUCED IN ANY FORM WITHOUT ITS WRITTEN PERMISSION.

**RPGA DESIGN GROUP, INC.**  
Architecture SpacePlanning Interiors  
1530 Rio Grande Ave. Fort Worth, Texas 76102 817.332.2477  
www.rpgaarchitects.com

**ABILENE HOUSING AUTHORITY**  
UNIT RENOVATIONS AT  
RIVIERA APARTMENTS

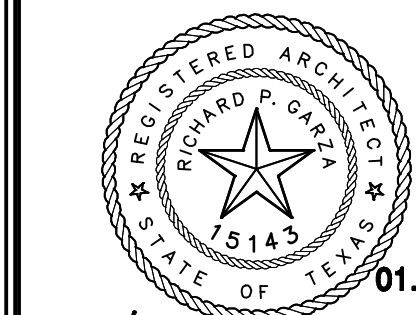

PROJECT NO. **2026-001**

SHEET NO. **A-2.02R**

UNIT PLANS

TEXAS

ABILENE,

01.30.2026

## **IV. Required Forms & Attachments**

### **A. Federal**

**U.S. Department of Housing  
and Urban Development**  
Office of Public and Indian Housing

**Representations, Certifications,  
and Other Statements of Bidders**  
**Public and Indian Housing Programs**

# Representations, Certifications, and Other Statements of Bidders

## Public and Indian Housing Programs

### Table of Contents

Clause	Page
1. Certificate of Independent Price Determination	1
2. Contingent Fee Representation and Agreement	1
3. Certification and Disclosure Regarding Payments to Influence Certain Federal Transactions	1
4. Organizational Conflicts of Interest Certification	2
5. Bidder's Certification of Eligibility	2
6. Minimum Bid Acceptance Period	2
7. Small, Minority, Women-Owned Business Concern Representation	2
8. Indian-Owned Economic Enterprise and Indian Organization Representation	2
9. Certification of Eligibility Under the Davis-Bacon Act	3
10. Certification of Nonsegregated Facilities	3
11. Clean Air and Water Certification	3
12. Previous Participation Certificate	3
13. Bidder's Signature	3

### 1. Certificate of Independent Price Determination

#### (a) The bidder certifies that--

(1) The prices in this bid have been arrived at independently, without, for the purpose of restricting competition, any consultation, communication, or agreement with any other bidder or competitor relating to (i) those prices, (ii) the intention to submit a bid, or (iii) the methods or factors used to calculate the prices offered;

(2) The prices in this bid have not been and will not be knowingly disclosed by the bidder, directly or indirectly, to any other bidder or competitor before bid opening (in the case of a sealed bid solicitation) or contract award (in the case of a competitive proposal solicitation) unless otherwise required by law; and

(3) No attempt has been made or will be made by the bidder to induce any other concern to submit or not to submit a bid for the purpose of restricting competition.

(b) Each signature on the bid is considered to be a certification by the signatory that the signatory--

(1) Is the person in the bidder's organization responsible for determining the prices being offered in this bid or proposal, and that the signatory has not participated and will not participate in any action contrary to subparagraphs (a)(1) through (a)(3) above; or

(2) (i) Has been authorized, in writing, to act as agent for the following principals in certifying that those principals have not participated, and will not participate in any action contrary to subparagraphs (a)(1) through (a)(3) above.

\_\_\_\_\_ [insert full name of person(s) in the bidder's organization responsible for determining the prices offered in this bid or proposal, and the title of his or her position in the bidder's organization];

(ii) As an authorized agent, does certify that the principals named in subdivision (b)(2)(i) above have not participated, and will not participate, in any action contrary to subparagraphs (a)(1) through (a)(3) above; and

(iii) As an agent, has not personally participated, and will not participate in any action contrary to subparagraphs (a)(1) through (a)(3) above.

(c) If the bidder deletes or modifies subparagraph (a)2 above, the bidder must furnish with its bid a signed statement setting forth in detail the circumstances of the disclosure.

[ ] [Contracting Officer check if following paragraph is applicable]

(d) Non-collusive affidavit. (applicable to contracts for construction and equipment exceeding \$50,000)

(1) Each bidder shall execute, in the form provided by the PHA/IHA, an affidavit to the effect that he/she has not colluded with any other person, firm or corporation in regard to any bid submitted in response to this solicitation. If the successful bidder did not submit the affidavit with his/her bid, he/she must submit it within three (3) working days of bid opening. Failure to submit the affidavit by that date may render the bid nonresponsive. No contract award will be made without a properly executed affidavit.

(2) A fully executed "Non-collusive Affidavit" [ ] is, [ ] is not included with the bid.

### 2. Contingent Fee Representation and Agreement

(a) Definitions. As used in this provision:

"Bona fide employee" means a person, employed by a bidder and subject to the bidder's supervision and control as to time, place, and manner of performance, who neither exerts, nor proposes to exert improper influence to solicit or obtain contracts nor holds out as being able to obtain any contract(s) through improper influence.

"Improper influence" means any influence that induces or tends to induce a PHA/IHA employee or officer to give consideration or to act regarding a PHA/IHA contract on any basis other than the merits of the matter.

(b) The bidder represents and certifies as part of its bid that, except for full-time bona fide employees working solely for the bidder, the bidder:

(1) [ ] has, [ ] has not employed or retained any person or company to solicit or obtain this contract; and

(2) [ ] has, [ ] has not paid or agreed to pay to any person or company employed or retained to solicit or obtain this contract any commission, percentage, brokerage, or other fee contingent upon or resulting from the award of this contract.

(c) If the answer to either (a)(1) or (a)(2) above is affirmative, the bidder shall make an immediate and full written disclosure to the PHA/IHA Contracting Officer.

(d) Any misrepresentation by the bidder shall give the PHA/IHA the right to (1) terminate the contract; (2) at its discretion, deduct from contract payments the amount of any commission, percentage, brokerage, or other contingent fee; or (3) take other remedy pursuant to the contract.

### 3. Certification and Disclosure Regarding Payments to Influence Certain Federal Transactions (applicable to contracts exceeding \$100,000)

(a) The definitions and prohibitions contained in Section 1352 of title 31, United States Code, are hereby incorporated by reference in paragraph (b) of this certification.

(b) The bidder, by signing its bid, hereby certifies to the best of his or her knowledge and belief as of December 23, 1989 that:

(1) No Federal appropriated funds have been paid or will be paid to any person for influencing or attempting to influence an officer or employee of any agency, a Member of Congress, an officer or employee of Congress, or an employee of a Member of Congress on his or her behalf in connection with the awarding of a contract resulting from this solicitation;

(2) If any funds other than Federal appropriated funds (including profit or fee received under a covered Federal transaction) have been paid, or will be paid, to any person for influencing or attempting to influence an officer or employee of any agency, a Member of Congress, an officer or employee of Congress, or an employee of a Member of Congress on his or her behalf in connection with this solicitation, the bidder shall complete and submit, with its bid, OMB standard form LLL, "Disclosure of Lobbying Activities;" and

(3) He or she will include the language of this certification in all subcontracts at any tier and require that all recipients of subcontract awards in excess of \$100,000 shall certify and disclose accordingly.

(c) Submission of this certification and disclosure is a prerequisite for making or entering into this contract imposed by section 1352, title 31, United States Code. Any person who makes an expenditure prohibited under this provision or who fails to file or amend the disclosure form to be filed or amended by this provision, shall be subject to a civil penalty of not less than \$10,000, and not more than \$100,000, for each such failure.

(d) Indian tribes (except those chartered by States) and Indian organizations as defined in section 4 of the Indian Self-Determination and Education Assistance Act (25 U.S.C. 450B) are exempt from the requirements of this provision.

#### 4. Organizational Conflicts of Interest Certification

The bidder certifies that to the best of its knowledge and belief and except as otherwise disclosed, he or she does not have any organizational conflict of interest which is defined as a situation in which the nature of work to be performed under this proposed contract and the bidder's organizational, financial, contractual, or other interests may, without some restriction on future activities:

- (a) Result in an unfair competitive advantage to the bidder; or,
- (b) Impair the bidder's objectivity in performing the contract work.

[ ] In the absence of any actual or apparent conflict, I hereby certify that to the best of my knowledge and belief, no actual or apparent conflict of interest exists with regard to my possible performance of this procurement.

#### 5. Bidder's Certification of Eligibility

(a) By the submission of this bid, the bidder certifies that to the best of its knowledge and belief, neither it, nor any person or firm which has an interest in the bidder's firm, nor any of the bidder's subcontractors, is ineligible to:

(1) Be awarded contracts by any agency of the United States Government, HUD, or the State in which this contract is to be performed; or,

(2) Participate in HUD programs pursuant to 24 CFR Part 24.

(b) The certification in paragraph (a) above is a material representation of fact upon which reliance was placed when making award. If it is later determined that the bidder knowingly rendered an erroneous certification, the contract may be terminated for default, and the bidder may be debarred or suspended from participation in HUD programs and other Federal contract programs.

#### 6. Minimum Bid Acceptance Period

(a) "Acceptance period," as used in this provision, means the number of calendar days available to the PHA/IHA for awarding a contract from the date specified in this solicitation for receipt of bids.

(b) This provision supersedes any language pertaining to the acceptance period that may appear elsewhere in this solicitation.

(c) The PHA/IHA requires a minimum acceptance period of [Contracting Officer insert time period] calendar days.

(d) In the space provided immediately below, bidders may specify a longer acceptance period than the PHA's/IHA's minimum requirement. The bidder allows the following acceptance period: calendar days.

(e) A bid allowing less than the PHA's/IHA's minimum acceptance period will be rejected.

(f) The bidder agrees to execute all that it has undertaken to do, in compliance with its bid, if that bid is accepted in writing within (1) the acceptance period stated in paragraph (c) above or (2) any longer acceptance period stated in paragraph (d) above.

#### 7. Small, Minority, Women-Owned Business Concern Representation

The bidder represents and certifies as part of its bid/ offer that it --

(a) [ ] is, [ ] is not a small business concern. "Small business concern," as used in this provision, means a concern, including its affiliates, that is independently owned and operated, not dominant in the field of operation in which it is bidding, and qualified as a small business under the criteria and size standards in 13 CFR 121.

(b) [ ] is, [ ] is not a women-owned business enterprise. "Women-owned business enterprise," as used in this provision, means a business that is at least 51 percent owned by a woman or women who are U.S. citizens and who also control and operate the business.

(c) [ ] is, [ ] is not a minority business enterprise. "Minority business enterprise," as used in this provision, means a business which is at least 51 percent owned or controlled by one or more minority group members or, in the case of a publicly owned business, at least 51 percent of its voting stock is owned by one or more minority group members, and whose management and daily operations are controlled by one or more such individuals. For the purpose of this definition, minority group members are:

(Check the block applicable to you)

- [ ] Black Americans [ ] Asian Pacific Americans
- [ ] Hispanic Americans [ ] Asian Indian Americans
- [ ] Native Americans [ ] Hasidic Jewish Americans

#### 8. Indian-Owned Economic Enterprise and Indian Organization Representation (applicable only if this solicitation is for a contract to be performed on a project for an Indian Housing Authority)

The bidder represents and certifies that it:

(a) [ ] is, [ ] is not an Indian-owned economic enterprise. "Economic enterprise," as used in this provision, means any commercial, industrial, or business activity established or organized for the purpose of profit, which is at least 51 percent Indian owned. "Indian," as used in this provision, means any person who is a member of any tribe, band, group, pueblo, or community which is recognized by the Federal Government as eligible for services from the Bureau of Indian Affairs and any "Native" as defined in the Alaska Native Claims Settlement Act.

(b) [ ] is, [ ] is not an Indian organization. "Indian organization," as used in this provision, means the governing body of any Indian tribe or entity established or recognized by such governing body. Indian "tribe" means any Indian tribe, band, group, pueblo, or

community including Native villages and Native groups (including corporations organized by Kenai, Juneau, Sitka, and Kodiak) as defined in the Alaska Native Claims Settlement Act, which is recognized by the Federal Government as eligible for services from the Bureau of Indian Affairs.

**9. Certification of Eligibility Under the Davis-Bacon Act** (applicable to construction contracts exceeding \$2,000)

(a) By the submission of this bid, the bidder certifies that neither it nor any person or firm who has an interest in the bidder's firm is a person or firm ineligible to be awarded contracts by the United States Government by virtue of section 3(a) of the Davis-Bacon Act or 29 CFR 5.12(a)(1).

(b) No part of the contract resulting from this solicitation shall be subcontracted to any person or firm ineligible to be awarded contracts by the United States Government by virtue of section 3(a) of the Davis-Bacon Act or 29 CFR 5.12(a)(1).

(c) The penalty for making false statements is prescribed in the U. S. Criminal Code, 18 U.S.C. 1001.

**10. Certification of Nonsegregated Facilities** (applicable to contracts exceeding \$10,000)

(a) The bidder's attention is called to the clause entitled **Equal Employment Opportunity** of the General Conditions of the Contract for Construction.

(b) "Segregated facilities," as used in this provision, means any waiting rooms, work areas, rest rooms and wash rooms, restaurants and other eating areas, time clocks, locker rooms and other storage or dressing areas, parking lots, drinking fountains, recreation or entertainment areas, transportation, and housing facilities provided for employees, that are segregated by explicit directive or are in fact segregated on the basis of race, color, religion, or national origin because of habit, local custom, or otherwise.

(c) By the submission of this bid, the bidder certifies that it does not and will not maintain or provide for its employees any segregated facilities at any of its establishments, and that it does not and will not permit its employees to perform their services at any location under its control where segregated facilities are maintained. The bidder agrees that a breach of this certification is a violation of the Equal Employment Opportunity clause in the contract.

(d) The bidder further agrees that (except where it has obtained identical certifications from proposed subcontractors for specific time periods) prior to entering into subcontracts which exceed \$10,000 and are not exempt from the requirements of the Equal Employment Opportunity clause, it will:

- (1) Obtain identical certifications from the proposed subcontractors;
- (2) Retain the certifications in its files; and
- (3) Forward the following notice to the proposed subcontractors (except if the proposed subcontractors have submitted identical certifications for specific time periods):

**Notice to Prospective Subcontractors of Requirement for Certifications of Nonsegregated Facilities**

A Certification of Nonsegregated Facilities must be submitted before the award of a subcontract exceeding \$10,000 which is not exempt from the provisions of the Equal Employment Opportunity clause of the prime contract. The certification may be submitted either for each subcontract or for all subcontracts during a period (i.e., quarterly, semiannually, or annually).

**Note:** The penalty for making false statements in bids is prescribed in 18 U.S.C. 1001.

**11. Clean Air and Water Certification** (applicable to contracts exceeding \$100,000)

The bidder certifies that:

(a) Any facility to be used in the performance of this contract [ ] is, [ ] is not listed on the Environmental Protection Agency List of Violating Facilities:

(b) The bidder will immediately notify the PHA/IHA Contracting Officer, before award, of the receipt of any communication from the Administrator, or a designee, of the Environmental Protection Agency, indicating that any facility that the bidder proposes to use for the performance of the contract is under consideration to be listed on the EPA List of Violating Facilities; and,

(c) The bidder will include a certification substantially the same as this certification, including this paragraph (c), in every nonexempt subcontract.

**12. Previous Participation Certificate** (applicable to construction and equipment contracts exceeding \$50,000)

(a) The bidder shall complete and submit with his/her bid the Form HUD-2530, "Previous Participation Certificate." If the successful bidder does not submit the certificate with his/her bid, he/she must submit it within three (3) working days of bid opening. Failure to submit the certificate by that date may render the bid nonresponsive. No contract award will be made without a properly executed certificate.

(b) A fully executed "Previous Participation Certificate" [ ] is, [ ] is not included with the bid.

**13. Bidder's Signature**

The bidder hereby certifies that the information contained in these certifications and representations is accurate, complete, and current.

\_\_\_\_\_  
(Signature and Date)

\_\_\_\_\_  
(Typed or Printed Name)

\_\_\_\_\_  
(Title)

\_\_\_\_\_  
(Company Name)

\_\_\_\_\_  
(Company Address)



## Insurance Requirements

Insurance Coverage Type	Required Minimums
<b>Professional Liability</b>	
AHA and its affiliates must be named as a Certificate Holder. This is required for vendors who render observational services to AHA such as appraisers, inspectors, attorneys, engineers or consultants.	\$1,000,000
<b>Business Automobile Liability</b>	
AHA and its affiliates must be named as an additional insured and as the certificate holder. This is required for any vendor that will be using their vehicle(s) to do work on AHA properties.	<i>\$500,000 Combined Single Limit Per Occurrence</i>
<b>Workers Compensation and Employer's Liability</b>	
Workers' Compensation coverage is Statutory and has no pre-set limits. Employer's Liability limit is \$500,000. Workers' Compensation is required for any vendor made up of more than two persons. <b><i>A Waiver of Subrogation in favor of AHA must be included in the Workers' Compensation policy.</i></b>  <b><i>AHA and its affiliates must be a Certificate Holder.</i></b>	<i>Statutory Employers Liability is \$500,000</i>
<b>Commercial General Liability</b>	
This is required for any vendor who will be doing hands-on work at AHA properties. AHA and its affiliates must be named as an Additional Insured and as the Certificate Holder.	<i>\$1,000,000 per accident \$2,000,000 aggregate or per project specifications, whichever is higher</i>
<b>Builder's Risk</b>	
Builder shall carry Builder's Risk to cover the loss of materials, and/or the building under construction/rehabilitation. AHA and its affiliates must be named as an Additional Insured and as the Certificate Holder.	<i>Equal to the Contract Cost of the construction or rehabilitation project stated in the contract.</i>

## DISCLOSURE OF LOBBYING ACTIVITIES

Complete this form to disclose lobbying activities pursuant to 31 U.S.C. 1352

Approved by OMB

0348-0046

(See reverse for public burden disclosure.)

<b>1. Type of Federal Action:</b> <input type="checkbox"/> a. contract <input type="checkbox"/> b. grant <input type="checkbox"/> c. cooperative agreement <input type="checkbox"/> d. loan <input type="checkbox"/> e. loan guarantee <input type="checkbox"/> f. loan insurance	<b>2. Status of Federal Action:</b> <input type="checkbox"/> a. bid/offer/application <input type="checkbox"/> b. initial award <input type="checkbox"/> c. post-award	<b>3. Report Type:</b> <input type="checkbox"/> a. initial filing <input type="checkbox"/> b. material change <b>For Material Change Only:</b> year _____ quarter _____ date of last report _____
<b>4. Name and Address of Reporting Entity:</b> <input type="checkbox"/> Prime <input type="checkbox"/> Subawardee Tier _____, <i>if known</i> :  <b>Congressional District, if known:</b>	<b>5. If Reporting Entity in No. 4 is a Subawardee, Enter Name and Address of Prime:</b>   <b>Congressional District, if known:</b>	
<b>6. Federal Department/Agency:</b>	<b>7. Federal Program Name/Description:</b>  CFDA Number, <i>if applicable</i> : _____	
<b>8. Federal Action Number, if known:</b>	<b>9. Award Amount, if known:</b> \$ _____	
<b>10. a. Name and Address of Lobbying Registrant</b> <i>(if individual, last name, first name, MI):</i>	<b>b. Individuals Performing Services</b> <i>(including address if different from No. 10a)</i> <i>(last name, first name, MI):</i>	
<b>11.</b> Information requested through this form is authorized by title 31 U.S.C. section 1352. This disclosure of lobbying activities is a material representation of fact upon which reliance was placed by the tier above when this transaction was made or entered into. This disclosure is required pursuant to 31 U.S.C. 1352. This information will be available for public inspection. Any person who fails to file the required disclosure shall be subject to a civil penalty of not less than \$10,000 and not more than \$100,000 for each such failure.	Signature: _____ Print Name: _____ Title: _____ Telephone No.: _____ Date: _____	
<b>Federal Use Only:</b>		Authorized for Local Reproduction Standard Form LLL (Rev. 7-97)

## INSTRUCTIONS FOR COMPLETION OF SF-LLL, DISCLOSURE OF LOBBYING ACTIVITIES

This disclosure form shall be completed by the reporting entity, whether subawardee or prime Federal recipient, at the initiation or receipt of a covered Federal action, or a material change to a previous filing, pursuant to title 31 U.S.C. section 1352. The filing of a form is required for each payment or agreement to make payment to any lobbying entity for influencing or attempting to influence an officer or employee of any agency, a Member of Congress, an officer or employee of Congress, or an employee of a Member of Congress in connection with a covered Federal action. Complete all items that apply for both the initial filing and material change report. Refer to the implementing guidance published by the Office of Management and Budget for additional information.

1. Identify the type of covered Federal action for which lobbying activity is and/or has been secured to influence the outcome of a covered Federal action.
2. Identify the status of the covered Federal action.
3. Identify the appropriate classification of this report. If this is a followup report caused by a material change to the information previously reported, enter the year and quarter in which the change occurred. Enter the date of the last previously submitted report by this reporting entity for this covered Federal action.
4. Enter the full name, address, city, State and zip code of the reporting entity. Include Congressional District, if known. Check the appropriate classification of the reporting entity that designates if it is, or expects to be, a prime or subaward recipient. Identify the tier of the subawardee, e.g., the first subawardee of the prime is the 1st tier. Subawards include but are not limited to subcontracts, subgrants and contract awards under grants.
5. If the organization filing the report in item 4 checks "Subawardee," then enter the full name, address, city, State and zip code of the prime Federal recipient. Include Congressional District, if known.
6. Enter the name of the Federal agency making the award or loan commitment. Include at least one organizational level below agency name, if known. For example, Department of Transportation, United States Coast Guard.
7. Enter the Federal program name or description for the covered Federal action (item 1). If known, enter the full Catalog of Federal Domestic Assistance (CFDA) number for grants, cooperative agreements, loans, and loan commitments.
8. Enter the most appropriate Federal identifying number available for the Federal action identified in item 1 (e.g., Request for Proposal (RFP) number; Invitation for Bid (IFB) number; grant announcement number; the contract, grant, or loan award number; the application/proposal control number assigned by the Federal agency). Include prefixes, e.g., "RFP-DE-90-001."
9. For a covered Federal action where there has been an award or loan commitment by the Federal agency, enter the Federal amount of the award/loan commitment for the prime entity identified in item 4 or 5.
10. (a) Enter the full name, address, city, State and zip code of the lobbying registrant under the Lobbying Disclosure Act of 1995 engaged by the reporting entity identified in item 4 to influence the covered Federal action.  
  
(b) Enter the full names of the individual(s) performing services, and include full address if different from 10 (a). Enter Last Name, First Name, and Middle Initial (MI).
11. The certifying official shall sign and date the form, print his/her name, title, and telephone number.

According to the Paperwork Reduction Act, as amended, no persons are required to respond to a collection of information unless it displays a valid OMB Control Number. The valid OMB control number for this information collection is OMB No. 0348-0046. Public reporting burden for this collection of information is estimated to average 10 minutes per response, including time for reviewing instructions, searching existing data sources, gathering and maintaining the data needed, and completing and reviewing the collection of information. Send comments regarding the burden estimate or any other aspect of this collection of information, including suggestions for reducing this burden, to the Office of Management and Budget, Paperwork Reduction Project (0348-0046), Washington, DC 20503.

# Certification of Payments to Influence Federal Transactions

U.S. Department of Housing and Urban Development  
Office of Public and Indian Housing

Public reporting burden for this information collection is estimated to average 30 minutes, including the time for reviewing instructions, searching existing data sources, gathering and maintaining the data needed, and completing and reviewing the collection of information. The information requested is required to obtain a benefit. This form is used to ensure federal funds are not used to influence members of Congress. There are no assurances of confidentiality. HUD may not conduct or sponsor, and an applicant is not required to respond to a collection of information unless it displays a currently valid OMB control number. Comments regarding the accuracy of this burden estimate and any suggestions for reducing this burden can be sent to the Reports Management Officer, Office of Policy Development and Research, REE, Department of Housing and Urban Development, 451 7th St SW, Room 4176, Washington, DC 20410-5000. When providing comments, please refer to OMB Approval No. 2577-0157.

Applicant Name

Program/Activity Receiving Federal Grant Funding

The undersigned certifies, to the best of his or her knowledge and belief, that:

(1) No Federal appropriated funds have been paid or will be paid, by or on behalf of the undersigned, to any person for influencing or attempting to influence an officer or employee of an agency, a Member of Congress, an officer or employee of Congress, or an employee of a Member of Congress in connection with the awarding of any Federal contract, the making of any Federal grant, the making of any Federal loan, the entering into of any cooperative agreement, and the extension, continuation, renewal, amendment, or modification of any Federal contract, grant, loan, or cooperative agreement.

(2) If any funds other than Federal appropriated funds have been paid or will be paid to any person for influencing or attempting to influence an officer or employee of an agency, a Member of Congress, an officer or employee of Congress, or an employee of a Member of Congress in connection with this Federal contract, grant, loan, or cooperative agreement, the undersigned shall complete and submit Standard Form-LLL, Disclosure Form to Report Lobbying, in accordance with its instructions.

(3) The undersigned shall require that the language of this certification be included in the award documents for all subawards at all tiers (including subcontracts, subgrants, and contracts under grants, loans, and cooperative agreements) and that all sub recipients shall certify and disclose accordingly.

This certification is a material representation of fact upon which reliance was placed when this transaction was made or entered into. Submission of this certification is a prerequisite for making or entering into this transaction imposed by Section 1352, Title 31, U.S. Code. Any person who fails to file the required certification shall be subject to a civil penalty of not less than \$10,000 and not more than \$100,000 for each such failure.

I hereby certify that all the information stated herein, as well as any information provided in the accompaniment herewith, is true and accurate. **Warning:** HUD will prosecute false claims and statements. Conviction may result in criminal and/or civil penalties. (18 U.S.C. 1001, 1010, 1012; 31 U.S.C. 3729, 3802)

Name of Authorized Official

Title

Signature

Date (mm/dd/yyyy)

## **IV. Required Forms & Attachments**

### **B. AHA and State of Texas Forms**



# BID TABULATION

## ATTACHMENT C

**Project Name: Unit Renovations 4 Units Riviera & Brailsford  
IFB AHA-2026-004**

Date: \_\_\_\_\_

Base Bid Amount: \_\_\_\_\_  
(Written amount)

Base Bid Amount: \$ \_\_\_\_\_  
(Numerical amount)

The Base Bid Amount shown above consists of the following:

Pricing Item	Unit	Firm Fixed Fee to Complete Unit Renovaion work per Scope of Work Provided in Attachment H and H1	Firm Fixed Fee to Complete Unit Renovaion work per Scope of Work Provided in Attachment H and H1
		LABOR COST	MATERIALS COST
1	B25	\$	\$
2	D6	\$	\$
3	102	\$	\$
4	208	\$	\$
Total Bid for Project:		\$	

Any errors made by the bidder in calculating the Base Bid Amount may be cause for the rejection of the bid.

1. The bid prices shall be included as provided for in the attached IFB. Unless otherwise specified in the bid, all prices shall be on a firm-fixed-price basis and are not subject to adjustment based on costs incurred.
2. **Liquidated Damages:** As actual damages for any delay in completion are impossible to determine, the contractor and his surety shall be liable for and shall pay to the Housing Authority of the City of Bridgeport the sum hereinafter stipulated as fixed and agreed liquidated damages for each day of delay until the work is completed and accepted. **\$200 per calendar day.**

Refer to HUD General Conditions, Paragraph 33, Liquidated Damages.

# BID TABULATION

ATTACHMENT C

**Project Name: Unit Renovations 4 Units Riviera & Brailsford  
IFB AHA-2026-004**

NOTE: The penalty for making false statements in offers is prescribed in 18 u. a. c. 1001.

Bidder Acknowledgment: By signing below, the Bidder certifies that it has reviewed the IFB, drawings, and all requirements; that the prices submitted are firm, complete, and include all labor, materials, and costs necessary to perform the work; and that the Bidder agrees to comply with all AHA specifications, material standards, and contract terms. Failure to sign this acknowledgment may result in the bid being deemed non-responsive.

---

Signature

---

Date

---

Printed Name

---

Title

---

Business Name

---

Business Address

# CERTIFICATE OF INTERESTED PARTIES

FORM 1295

Complete Nos. 1 - 4 and 6 if there are interested parties.  
 Complete Nos. 1, 2, 3, 5, and 6 if there are no interested parties.

**OFFICE USE ONLY**

1 Name of business entity filing form, and the city, state and country of the business entity's place of business.

2 Name of governmental entity or state agency that is a party to the contract for which the form is being filed.

3 Provide the identification number used by the governmental entity or state agency to track or identify the contract, and provide a description of the services, goods, or other property to be provided under the contract.

4 Name of Interested Party	City, State, Country (place of business)	Nature of Interest (check applicable)	
		Controlling	Intermediary

5 Check only if there is NO Interested Party.

**6 UNSWORN DECLARATION**

My name is \_\_\_\_\_, and my date of birth is \_\_\_\_\_.

My address \_\_\_\_\_, \_\_\_\_\_, \_\_\_\_\_, \_\_\_\_\_, \_\_\_\_\_.  
 (street) (city) (state) (zip code) (country)

I declare under penalty of perjury that the foregoing is true and correct.

Executed in \_\_\_\_\_ County, State of \_\_\_\_\_, on the \_\_\_\_\_ day of \_\_\_\_\_, 20\_\_\_\_.  
 (month) (year)

\_\_\_\_\_  
 Signature of authorized agent of contracting business entity  
 (Declarant)

**ADD ADDITIONAL PAGES AS NECESSARY**

# CONFLICT OF INTEREST QUESTIONNAIRE

For vendor doing business with local governmental entity

## FORM CIQ

**This questionnaire reflects changes made to the law by H.B. 23, 84th Leg., Regular Session.**

This questionnaire is being filed in accordance with Chapter 176, Local Government Code, by a vendor who has a business relationship as defined by Section 176.001(1-a) with a local governmental entity and the vendor meets requirements under Section 176.006(a).

By law this questionnaire must be filed with the records administrator of the local governmental entity not later than the 7th business day after the date the vendor becomes aware of facts that require the statement to be filed. See Section 176.006(a-1), Local Government Code.

A vendor commits an offense if the vendor knowingly violates Section 176.006, Local Government Code. An offense under this section is a misdemeanor.

### OFFICE USE ONLY

Date Received

**1 Name of vendor who has a business relationship with local governmental entity.**

**2**  **Check this box if you are filing an update to a previously filed questionnaire.** (The law requires that you file an updated completed questionnaire with the appropriate filing authority not later than the 7th business day after the date on which you became aware that the originally filed questionnaire was incomplete or inaccurate.)

**3 Name of local government officer about whom the information is being disclosed.**

\_\_\_\_\_  
Name of Officer

**4 Describe each employment or other business relationship with the local government officer, or a family member of the officer, as described by Section 176.003(a)(2)(A). Also describe any family relationship with the local government officer. Complete subparts A and B for each employment or business relationship described. Attach additional pages to this Form CIQ as necessary.**

A. Is the local government officer or a family member of the officer receiving or likely to receive taxable income, other than investment income, from the vendor?

Yes  No

B. Is the vendor receiving or likely to receive taxable income, other than investment income, from or at the direction of the local government officer or a family member of the officer AND the taxable income is not received from the local governmental entity?

Yes  No

**5 Describe each employment or business relationship that the vendor named in Section 1 maintains with a corporation or other business entity with respect to which the local government officer serves as an officer or director, or holds an ownership interest of one percent or more.**

**6**  Check this box if the vendor has given the local government officer or a family member of the officer one or more gifts as described in Section 176.003(a)(2)(B), excluding gifts described in Section 176.003(a-1).

**7**

\_\_\_\_\_  
Signature of vendor doing business with the governmental entity

\_\_\_\_\_  
Date

## **CONFLICT OF INTEREST QUESTIONNAIRE**

### **For vendor doing business with local governmental entity**

A complete copy of Chapter 176 of the Local Government Code may be found at <http://www.statutes.legis.state.tx.us/Docs/LG/htm/LG.176.htm>. For easy reference, below are some of the sections cited on this form.

**Local Government Code § 176.001(1-a)**: "Business relationship" means a connection between two or more parties based on commercial activity of one of the parties. The term does not include a connection based on:

- (A) a transaction that is subject to rate or fee regulation by a federal, state, or local governmental entity or an agency of a federal, state, or local governmental entity;
- (B) a transaction conducted at a price and subject to terms available to the public; or
- (C) a purchase or lease of goods or services from a person that is chartered by a state or federal agency and that is subject to regular examination by, and reporting to, that agency.

**Local Government Code § 176.003(a)(2)(A) and (B)**:

(a) A local government officer shall file a conflicts disclosure statement with respect to a vendor if:

\*\*\*

(2) the vendor:

(A) has an employment or other business relationship with the local government officer or a family member of the officer that results in the officer or family member receiving taxable income, other than investment income, that exceeds \$2,500 during the 12-month period preceding the date that the officer becomes aware that

- (i) a contract between the local governmental entity and vendor has been executed; or
- (ii) the local governmental entity is considering entering into a contract with the vendor;

(B) has given to the local government officer or a family member of the officer one or more gifts that have an aggregate value of more than \$100 in the 12-month period preceding the date the officer becomes aware that:

- (i) a contract between the local governmental entity and vendor has been executed; or
- (ii) the local governmental entity is considering entering into a contract with the vendor.

**Local Government Code § 176.006(a) and (a-1)**

(a) A vendor shall file a completed conflict of interest questionnaire if the vendor has a business relationship with a local governmental entity and:

- (1) has an employment or other business relationship with a local government officer of that local governmental entity, or a family member of the officer, described by Section 176.003(a)(2)(A);
- (2) has given a local government officer of that local governmental entity, or a family member of the officer, one or more gifts with the aggregate value specified by Section 176.003(a)(2)(B), excluding any gift described by Section 176.003(a-1); or
- (3) has a family relationship with a local government officer of that local governmental entity.

(a-1) The completed conflict of interest questionnaire must be filed with the appropriate records administrator not later than the seventh business day after the later of:

(1) the date that the vendor:

- (A) begins discussions or negotiations to enter into a contract with the local governmental entity; or
- (B) submits to the local governmental entity an application, response to a request for proposals or bids, correspondence, or another writing related to a potential contract with the local governmental entity; or

(2) the date the vendor becomes aware:

- (A) of an employment or other business relationship with a local government officer, or a family member of the officer, described by Subsection (a);
- (B) that the vendor has given one or more gifts described by Subsection (a); or
- (C) of a family relationship with a local government officer.



**PROFILE OF FIRM FORM (Page 1 of 2)**

Prime     Joint Venture/Partner     Sub-Contractor    (This form shall be completed by and for each).

Legal Name of Firm: \_\_\_\_\_

DBA (if applicable): \_\_\_\_\_

Telephone: \_\_\_\_\_ Fax: \_\_\_\_\_

Street Address, City, State, Zip: \_\_\_\_\_

**Identify principals/partners in firm:**

Name	Title	% of Ownership

**Indicate the operating structure of the firm:**

<input type="checkbox"/> Publicly Held Corporation	<input type="checkbox"/> Privately Held Corporation	<input type="checkbox"/> Government Agency	<input type="checkbox"/> Non-Profit Organization	<input type="checkbox"/> Partnership	<input type="checkbox"/> Sole Proprietorship
--	---	--	--	--------------------------------------	--

**Proposer's Diversity Statement**

You must check all of the following that apply to the ownership of this firm and enter where provided the correct percentage (%) of ownership of each.

Minority (MBE) or Woman-Owned (WBE) Business Enterprises qualify by virtue of 51% or more ownership and active management by one or more of the following:

<input type="checkbox"/> African American _____ %	<input type="checkbox"/> Native American _____ %	<input type="checkbox"/> Hispanic American _____ %	<input type="checkbox"/> Asian/Pacific American _____ %	<input type="checkbox"/> Hasidic Jew _____ %	<input type="checkbox"/> Asian/Indian American _____ %
<input type="checkbox"/> Woman-Owned (MBE) _____ %	<input type="checkbox"/> Woman-Owned (Caucasian) _____ %	<input type="checkbox"/> Disabled Veteran _____ %	<input type="checkbox"/> Caucasian American (Male) _____ %	<input type="checkbox"/> Other (Specify): _____ _____ %	

**Is the business 51% or more owned by a public housing resident?**     Yes     No

If yes, provide name and address of the public housing facility:

Facility Name: \_\_\_\_\_

Facility Address: \_\_\_\_\_ City: \_\_\_\_\_

**SWMBE Certification Number:** \_\_\_\_\_

(NOTE: A CERTIFICATION NUMBER IS NOT REQUIRED. ENTER IF AVAILABLE.)

**Certification Agency:** \_\_\_\_\_

**Federal Tax ID Number:** \_\_\_\_\_

**City of San Antonio Business License No.:** \_\_\_\_\_

**State of Texas License Type and No.:** \_\_\_\_\_



**PROFILE OF FIRM FORM (Page 2 of 2)**

Has your firm or any member of your firm been a party to litigation with a public entity? If yes, when, with whom and state the circumstances and any resolution.

\_\_\_\_\_  
\_\_\_\_\_

Has your firm or any member of your firm ever sued or been sued by any Public Housing Agency or its affiliated entities? If yes, when and state the circumstances and any resolution of the lawsuit.

\_\_\_\_\_  
\_\_\_\_\_

Has your firm or any member of your firm ever had a claim brought against because of breach of contract or non-performance? If yes, when and state the circumstances and any resolution of the matter.

\_\_\_\_\_  
\_\_\_\_\_

**Debarred Statement:** Has this firm, or any principal(s) ever been debarred from providing any services by the Federal Government, any state government, the State of Texas, or any local government agency within or without the State of Texas?

Yes  No

If "Yes," please attach a full detailed explanation, including dates, circumstances and current status. **Initials** \_\_\_\_\_

**Disclosure Statement:** Does this firm or any principals thereof have any current, past personal or professional relationship with any Commissioner or Officer of AHA?  Yes  No

If "Yes," please attach a full detailed explanation, including dates, circumstances and current status. **Initials** \_\_\_\_\_

**Non-Collusive Affidavit:** The undersigned party submitting this proposal hereby certifies that such proposal is genuine and not collusive and that said Offeror has not colluded, conspired, connived or agreed, directly or indirectly, with any Offeror or person, to put in a sham proposal or to refrain from proposing, and has not in any manner, directly or indirectly sought by agreement or collusion, or communication or conference, with any person, to fix the proposal price of affiant or of any other Offeror, to fix overhead, profit or cost element of said proposal price, or that of any other Offeror or to secure any advantage against the AHA or any person interested in the proposed contract; and that all statements in said proposal are true.

**Initials** \_\_\_\_\_

**Verification Statement:** The undersigned Offeror hereby states that by completing and submitting this form he/she is verifying that all information provided herein is, to the best of his/her knowledge, true and accurate, and agrees that if the SAHA discovers that any information entered herein is false, that shall entitle the AHA to not consider nor make award or to cancel any award with the undersigned party.

**Initials** \_\_\_\_\_

In performing this contract, the contractor(s) shall comply with any and all applicable federal, state or local laws including but not limited to: Occupational Safety & Health, Equal Employment Opportunity, Immigration and Naturalization, The Americans with Disabilities Act, State Tax and Insurance Law, and the Fair Housing Act.

**Initials** \_\_\_\_\_

\_\_\_\_\_  
**Signature**

\_\_\_\_\_  
**Date**

\_\_\_\_\_  
**Printed Name**

\_\_\_\_\_  
**Company**



## Company Biography

**Company Name:** \_\_\_\_\_

**Headquarters Location:** \_\_\_\_\_

**Field Office Location(s):** \_\_\_\_\_

\_\_\_\_\_

\_\_\_\_\_

\_\_\_\_\_

**Business Specialty or Focus:** \_\_\_\_\_

**Number of Full Time Staff:** \_\_\_\_\_

**Founding Date and Brief History:** \_\_\_\_\_

\_\_\_\_\_

\_\_\_\_\_

\_\_\_\_\_

**Texas Projects and/or Clients (Past and Current):** \_\_\_\_\_

\_\_\_\_\_

\_\_\_\_\_

\_\_\_\_\_

**Previous Housing Authority Experience:**      YES      NO

**List the Authorities:** \_\_\_\_\_

\_\_\_\_\_

\_\_\_\_\_



## *Listing of Proposed Subcontractors*

***Note: A completed Profile of Firm Form must be submitted for each proposed subcontractor.***

<b>Sub #</b>	<b>Company Name / Individual</b>	<b>City and State</b>	<b>Specialty</b>	<b>Phone</b>
1				
2				
3				
4				
5				
6				

I understand and agree that if awarded a contract as a result of this solicitation that the use of the above subcontractors is subject to the approval of AHA and becomes a part of the contract. I further understand that any change in subcontractors also requires the pre-approval of AHA.

**Signature:** \_\_\_\_\_

\_\_\_\_\_  
**Printed Name & Title**

\_\_\_\_\_  
**Company Name**



## Section 3 Statement

### **SECTION 3 STATEMENT: (IF APPLICABLE)**

**Are you claiming a Section 3 business preference? YES \_\_\_ NO \_\_\_**  
**If “YES,” which category are you claiming?**

\_\_\_ Category I – Owned by a public housing resident where work is performed

\_\_\_ Category II – Owned by any other public housing resident

\_\_\_ Category III – HUD YouthBuild Program

\_\_\_ Category IV – 30% of workforce is Section 3 qualified or subcontract greater than 25% of contract value to certified Section 3 Business Concern



## Respondent's Certification

By signing below, Respondent certifies that the following statements are true and correct:

1. He/she has full authority to bind Respondent and that no member of Respondent's organization is disbarred, suspended or otherwise prohibited from contracting with any federal, state or local agency.
2. Items for which Bids were provided herein will be delivered as specified in the Bid.
3. In performing this contract, the contractor(s) shall comply with any and all applicable federal, state or local laws including but not limited to: Occupational Safety & Health, Equal Employment Opportunity, Immigration and Naturalization, The Americans with Disabilities Act, State Tax and Insurance Law, and the Fair Housing Act.
4. Respondent agrees that this bid shall remain open and valid for at least a period of 90 days from the date of the Bid Opening and that this bid shall constitute an offer, which, if accepted by Opportunity Home and subject to the terms and conditions of such acceptance, shall result in a contract between Opportunity Home and the undersigned Respondent.
5. He/she has not given, offered to give, nor intends to give at any time hereafter any economic opportunity, future employment, gift, loan, gratuity, special discount, trip, favor, or service to a public servant in connection with this Bid.
6. Respondent, nor the firm, corporation, partnership, or institution represented by the Respondent, or anyone acting for such firm, corporation or institution has violated the antitrust laws of the State of Texas or the Federal Antitrust laws, nor communicated directly or indirectly the bid made to any competitor or any other person engaged in such line of business.
7. Respondent has not received compensation for participation in the preparation of the specifications for this RFP.
8. **Non-Collusive Affidavit:** The undersigned party submitting this bid hereby certifies that such bid is genuine and not collusive and that said Respondent has not colluded, conspired, connived or agreed, directly or indirectly, with any Respondent or person, to put in a sham Bid or to refrain from bidding, and has not in any manner, directly or indirectly sought by agreement or collusion, or communication or conference, with any person, to fix the bid price of affiant or of any other Respondent, to fix overhead, profit or cost element of said bid price, or that of any other Respondent or to secure any advantage against Opportunity Home or any person interested in the proposed contract; and that all statements in said bid are true.
9. **Child Support:** Pursuant to Section 231.006 (d) of the Texas Family Code, regarding child support, the Respondent certifies that the individual or business entity named in this bid is not ineligible to receive the specified payment and acknowledges that this contract may be terminated and payment may be withheld if this certification is inaccurate.
10. **Lobbying Prohibition:** The Consultant agrees to comply with Section 1352 of Title 31, United States Code which prohibits the use of Federal appropriated funds to pay any person for influencing or attempting to influence an officer or employee of any agency, a Member of Congress, and officer or employee of Congress, or an employee of a Member of Congress in connection with any of the following covered Federal actions: the awarding of any Federal contract; the making of any Federal grant; the making of any Federal loan; the entering into of any cooperative agreement; or the modification of any Federal contract, grant, loan, or cooperative agreement.
11. **Non-Boycott of Israel:** Opportunity Home may not enter into a contract with a company for goods and services unless the contract contains a written verification from the company that; (i) it does not Boycott Israel; and (ii) will not Boycott Israel during the term of the contract. (Texas Government Code chapter 2270) by accepting these General Conditions and any associated contract, the CONTRACTOR certifies that it does not Boycott Israel, and agrees that during the term of this contract will not Boycott Israel as that term is defined in the Texas Government Code Section 808.001, as amended.
12. **TX Gov. Code 2252.152:** Prohibits a government entity from awarding a contract to a company engaged in business with Iran, Sudan, or a Foreign Terrorist Organization as identified on a list maintained by the Texas Comptroller of Public Accounts. By signature hereon Respondent certifies that it is not affiliated in any manner with the businesses on this list.

\_\_\_\_\_  
Signature

\_\_\_\_\_  
Printed Name

\_\_\_\_\_  
Company Phone

\_\_\_\_\_  
Company Name

\_\_\_\_\_  
Email Address



## Acknowledgement of Addendum's

Addendum #	Signature of Acknowledgement	Date Acknowledged
1		
2		
3		
4		

\_\_\_\_\_  
**Signature**

\_\_\_\_\_  
**Date**

\_\_\_\_\_  
**Printed Name**

\_\_\_\_\_  
**Company**

\_\_\_\_\_  
**Email Address**

\_\_\_\_\_  
**Phone Number**



## BUSINESS REFERENCES

By signing below, Respondent certifies that the following statements are true and correct:

<b>Company/Agency Name</b>		
<b>Contact Person</b>		<b>Phone:</b>
<b>Address</b>		
<b>Email</b>		
<b>Description of Engagement and \$ Value</b>		

<b>Company/Agency Name</b>		
<b>Contact Person</b>		<b>Phone:</b>
<b>Address</b>		
<b>Email</b>		
<b>Description of Engagement and \$ Value</b>		

<b>Company/Agency Name</b>		
<b>Contact Person</b>		<b>Phone:</b>
<b>Address</b>		
<b>Email</b>		
<b>Description of Engagement and \$ Value</b>		

Add as sheets as necessary to submit the proper number of references.



# FORM OF NON-COLLUSIVE AFFIDAVIT

(PRIME RESPONDER/BIDDER)

State of \_\_\_\_\_

County \_\_\_\_\_, being first duly sworn, deposes and says:

That he/she is \_\_\_\_\_, the party making the foregoing proposal or bid, and attests to the following:

1. That affiant employed no person, confirmation, firm, association, or other organization, either directly or indirectly, to secure the public contract under which he received payment, other than persons regularly employed by the Affiant whose services in connection with the construction of the public building or project in securing the public contract were in the regular course of their duties for Affiant; and
2. That no part of the contract price received by Affiant was paid to any person, corporation, firm, association or other organization for soliciting the contract, other than the payment of their normal compensation to persons regularly employed by the Affiant whose services in connection with the construction of the public building or project were in the regular course of their duties for Affiant.
3. That such proposal or bid is genuine and not collusive or sham; that said Bidder has not colluded, conspired, connived, or agreed, directly or indirectly, with any Bidder or person, to put in a sham bid or try to refrain from bidding, and has not in any manner directly or indirectly, sought by agreement or collusion, or communication or conference, with any person, to fix the bid price of Affiant or of any other Bidder, or to fix any overhead, profit, or cost element of said bid price, or of that of any other Bidder, or to secure any advantage against the Housing Authority or any person interested in the proposed contract; and that all statements in said proposal or bid are true.

\_\_\_\_\_  
Signature\*

\*Bidder if the Bidder is an individual; all partners if Bidder is a partnership; officer if the Bidder is a corporation.

SUBSCRIBED AND SWORN TO before me, this the \_\_\_\_ day of \_\_\_\_\_, 20\_\_

\_\_\_\_\_  
NOTARY PUBLIC

My Commission Expires: \_\_\_\_\_, 20\_\_